

Appendix K – Self-Evaluation Results – Park Facilities

A comprehensive overview of all public areas in City of Grand Rapids facilities was performed in 2019. The results of the evaluations are shown in the appendix below.

ADA Transition Plan
 2019 Inspection Summary
 Parks

Park Name	Accessiible Route			Parking Stalls			Surface Markings			Parking Signs			Curb Ramps			Play Component			Pavilion			Benches			Tables		
	Compliant	Noncompliant	Not Applicable	Compliant	Noncompliant	Not Applicable	Compliant	Noncompliant	Not Applicable	Compliant	Noncompliant	Not Applicable	Compliant	Noncompliant	Not Applicable	Compliant	Noncompliant	Not Applicable	Compliant	Noncompliant	Not Applicable	Compliant	Noncompliant	Not Applicable	Compliant	Noncompliant	Not Applicable
American Legion Memorial Park			X			X			X			X			X	X			X			X			X		
Angel of Hope		X			X			X			X				X			X		X		X			X		
Blandin Beach	X				X			X			X			X		X			X	X			X				
Central School	X			X			X				X			X				X	X			X			X		
Crystal Lake	X				X			X			X			X		X		X		X			X			X	
Grussendorf Park	X				X			X			X			X		X		X	X			X			X		
Hale Lake Landing			X			X			X			X			X			X			X			X	X		
Hillside Park			X			X			X			X			X			X			X			X			X
Isaac Walton Landing			X			X			X			X			X			X			X			X			X
Lost Creek Park		X			X			X			X			X		X		X	X			X			X		
Maplewood Park		X			X			X			X			X	X			X	X			X			X		
McGowans Park		X			X			X			X			X		X		X	X			X			X		
McKinney Lake Landing			X			X			X			X			X			X			X			X			X
Newtons Sliding Hill		X			X			X			X			X			X			X			X			X	
Oakland Park	X				X			X			X			X		X		X	X			X			X		
Pokegama Park Place	X			X			X			X			X				X		X		X			X			X
River Front Trail	X			X			X			X			X			X		X	X			X			X		
Skogebo Park			X			X			X			X			X			X			X			X			X
Sports Complex			X			X			X			X			X			X			X			X			X
Steamboat Landing	X				X			X			X			X			X			X			X			X	
Sylvan Landing	X				X			X			X			X			X		X	X			X			X	
Sylvan Point Trails	X				X			X			X			X		X		X			X			X			X
Veterans Memorial Park		X			X			X			X			X		X		X	X			X			X		
Wilcox Park		X			X			X			X			X		X		X			X			X			X
Willow Park		X			X			X			X			X	X			X			X			X	X		

ADA Checklist for Existing Facilities - Parks

City of Grand Rapids ADA Transition Plan

Building: American Legion Park

Location: _____

Date: 10/8/19

Evaluated By: Dom DeGuseppi

Priority 5 - Parks

5.1 Is there at least one route from site arrival points (parking, passenger loading zones, public sidewalks and public transportation stops) that does not require the use of stairs? [See 2010 ADA Standards for Accessible Design – 206.2.1]

Yes No

If yes, location of route:

Parking Yes No

5.2 If parking is provided for the public, are an adequate number of accessible spaces provided? [208.2]

Yes No

Total #:	Total Spaces	Accessible Spaces
Accessible #:	1 - 25	1
	26 - 50	2
	51 - 75	3
	76 - 100	4
	100+ see 2010 Standards 208.2	

Gravel, grass, and street parking



5.3 Are accessible spaces at least 8 feet wide with an access aisle at least 8 feet wide? [502.2, 502.3]

Yes No

Measurement:

Note: Two spaces may share an access aisle. Check state/local requirements;

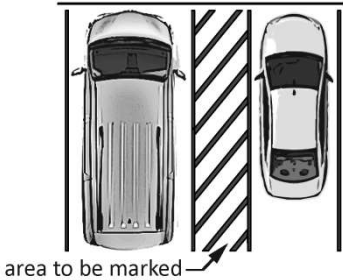
ADA Checklist for Existing Facilities - Parks

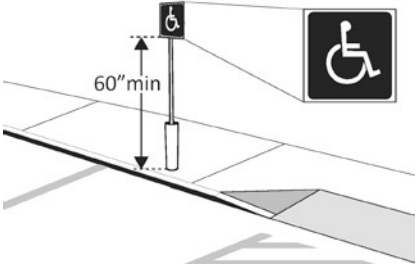
	some specify that each space have its own aisle.		
<p>5.4 Are the access aisles marked with signage and surface painting so as to discourage parking in them? [502.3.3]</p> <p>Note: The marking method and color may be addressed by state/local requirements.</p>	<p><input type="checkbox"/> Yes <input checked="" type="checkbox"/> No</p>		
<p>5.5 Is the slope of the accessible parking spaces and access aisles no steeper than 1:48 in all directions? [502.4]</p>	<p><input type="checkbox"/> Yes <input checked="" type="checkbox"/> No</p> <p>Measurement: NA</p>		
<p>5.6 Do the access aisles adjoin an accessible route? [502.3]</p>	<p><input type="checkbox"/> Yes <input checked="" type="checkbox"/> No</p>		
<p>5.7 Are accessible spaces identified with a sign that includes the International Symbol of Accessibility?</p> <p>Is the bottom of the sign at least 60 inches and not greater than 66 inches above the ground? [502.6]</p>	<p><input type="checkbox"/> Yes <input checked="" type="checkbox"/> No</p> <p><input type="checkbox"/> Yes <input checked="" type="checkbox"/> No</p> <p>Measurement:</p>		
<p>5.8 Of the total parking spaces, are the accessible spaces located on the closest accessible route to the accessible entrance(s)? [208.3.1]</p>	<p><input type="checkbox"/> Yes <input checked="" type="checkbox"/> No</p>		

Exterior Accessible Route

5.9 Is the route stable, firm and slip-resistant? [302.1] Yes No

5.10 Is the route at least 36 inches wide? [403.5.1] Yes No
Measurement: NA

Note: The accessible route can narrow to 32 inches min. for a max. of 24 inches. These narrower portions of the route must be at least 48 inches from each other.

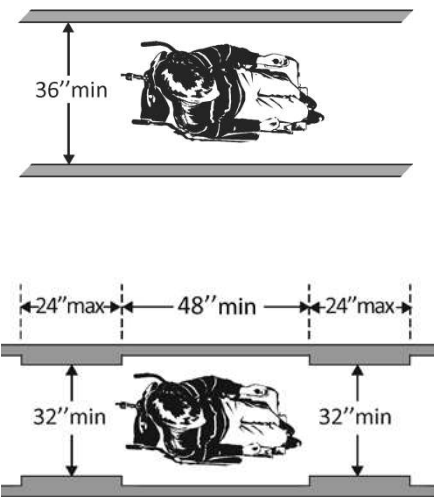

5.11 If the route is greater than 200 feet in length and less than 60 inches wide, is there a passing space no less than 60 x 60 inches? [403.5.3] Yes No
Measurement: NA

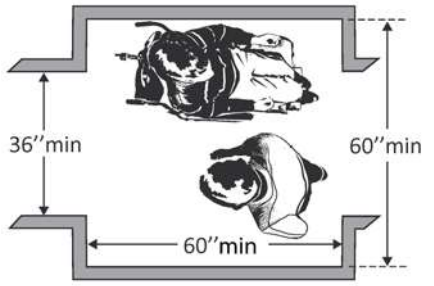

5.12 If there are grates or openings on the route, are the openings no larger than 1/2 inches? [403.5.3] If the route is greater than 200 feet in length and less than 60 inches wide, is there a passing space no less than 60 x 60 inches?

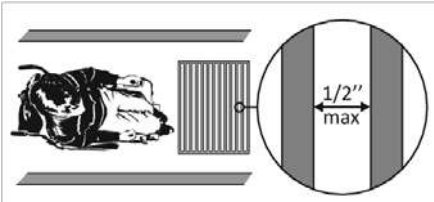

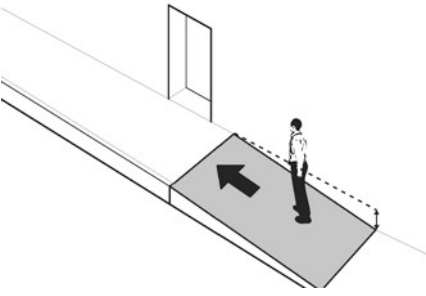
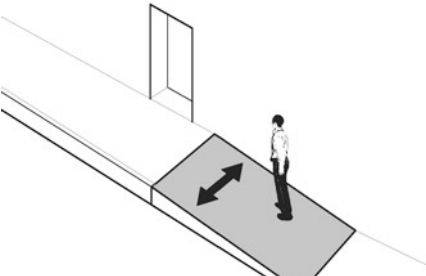
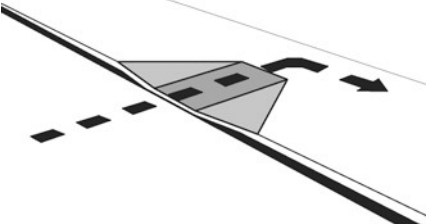
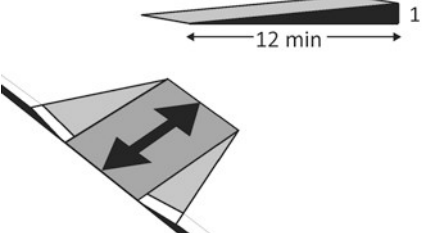
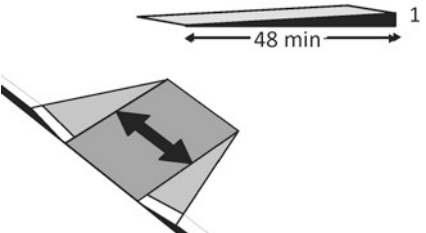
<p>5.13 Is the running slope no steeper than 1:20, i.e. for every inch of height change there are at least 20 inches of route run? [403.3]</p> <p>Note: If the running slope is steeper than 1:20, treat as a ramp and add features such as edge protection and handrails.</p>	<p><input type="checkbox"/> Yes <input checked="" type="checkbox"/> No</p> <p>Measurement: NA</p>		
<p>5.14 Is the cross slope no steeper than 1:48? [403.3]</p>	<p><input type="checkbox"/> Yes <input checked="" type="checkbox"/> No</p> <p>Measurement: NA</p>		
<p>Curb Ramps <input type="checkbox"/> Yes <input checked="" type="checkbox"/> No</p>			
<p>5.15 If the accessible route crosses a curb, is there a curb ramp? [402.2]</p>	<p><input type="checkbox"/> Yes <input type="checkbox"/> No</p>		
<p>5.16 Is the running slope of the curb ramp no steeper than 1:12, i.e. for every inch of height change there are at least 12 inches of curb ramp run? [406.1, 405.2]</p>	<p><input type="checkbox"/> Yes <input type="checkbox"/> No</p> <p>Measurement:</p>		
<p>5.17 Is the cross slope of the curb ramp, excluding flares, no steeper than 1:48? [406.1, 405.3]</p>	<p><input type="checkbox"/> Yes <input type="checkbox"/> No</p> <p>Measurement:</p>		

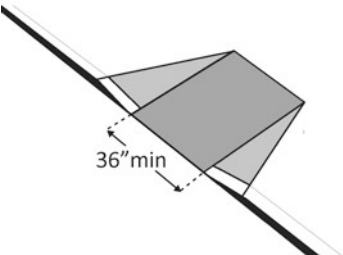
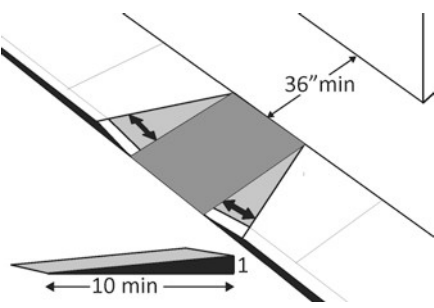
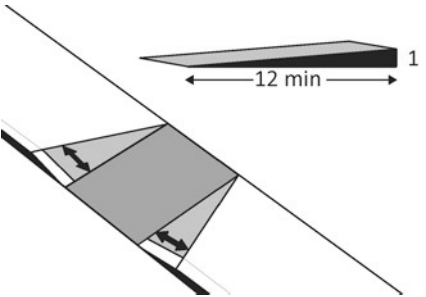
<p>5.18 Is the curb ramp, excluding flares, at least 36 inches wide? [406.1, 405.5]</p>	<p><input type="checkbox"/> Yes <input type="checkbox"/> No</p> <p>Measurement:</p>		
<p>5.19 At the top of the curb ramp is there a level landing (slope no steeper than 1:48 in all directions) that is at least 36 inches long and at least as wide as the curb ramp? [406.4]</p> <p>If there are curb ramp flares, are the slopes of the flares no steeper than 1:10, i.e. for every inch of height change there are at least 10 inches of flare run? [406.3]</p>	<p><input type="checkbox"/> Yes <input type="checkbox"/> No</p> <p>Measurement:</p> <p><input type="checkbox"/> Yes <input type="checkbox"/> No</p> <p>Measurement:</p>		
<p>5.20 If the landing at the top is less than 36 inches long, are there curb ramp flares? [406.4]</p> <p>Are the slopes of the flares no greater than 1:12, i.e. for every inch of height change there are at least 12 inches of flare run? [406.4]</p>	<p><input type="checkbox"/> Yes <input type="checkbox"/> No</p> <p><input type="checkbox"/> Yes <input type="checkbox"/> No</p> <p>Measurement:</p>		
<p>Accessible Play Components <input type="checkbox"/> Yes <input checked="" type="checkbox"/> No</p>			
<p>5.21 <u>Ground Level Play Components</u> Is there an accessible route to at least one of each type of ground level play component?</p> <p>Notes:</p> <ol style="list-style-type: none"> 1. A play component is an element designed to generate play, socialization and learning. 2. Ground level play components are components that can be approached and exited at 	<p><input type="checkbox"/> Yes <input type="checkbox"/> No</p>		

ADA Checklist for Existing Facilities - Parks

<p>ground level. Examples include rockers, swings, diggers and stand-alone slides.</p>			
<p>5.22 <u>Elevated Play Components</u> Are there any accessible elevated play components?</p> <p>If so, is there an accessible route to the components?</p>	<p><input type="checkbox"/> Yes <input type="checkbox"/> No</p> <p><input type="checkbox"/> Yes <input type="checkbox"/> No</p>		
<p>5.23 Is the vertical clearance of the accessible route at least 80 inches above the ground surface?</p> <p>Note: Objects below 80 inches may not protrude into the accessible route.</p>	<p><input type="checkbox"/> Yes <input type="checkbox"/> No</p>		
<p>Pavilion <input checked="" type="checkbox"/> Yes <input type="checkbox"/> No</p>			
<p>5.24 Is there an accessible route that is stable, firm and slip-resistant? [302.1]</p>	<p><input checked="" type="checkbox"/> Yes <input type="checkbox"/> No</p>		
<p>5.25 Is the route at least 36 inches wide? [403.5.1]</p>	<p><input checked="" type="checkbox"/> Yes <input type="checkbox"/> No</p>		
<p>5.26 Is the running slope no steeper than 1:20, i.e. for every inch of height change there are at least 20 inches of route run? [403.3]</p> <p>Note: If the running slope is steeper than 1:20, treat as a ramp and add features such as edge protection and handrails.</p>	<p><input type="checkbox"/> Yes <input checked="" type="checkbox"/> No</p> <p>Measurement: 8%</p>		

ADA Checklist for Existing Facilities - Parks

<p>5.27 Is the cross slope no steeper than 1:48? [403.3]</p>	<p><input checked="" type="checkbox"/> Yes <input type="checkbox"/> No</p> <p>Measurement: 1.3%</p>	
---	--	--

Benches Yes No

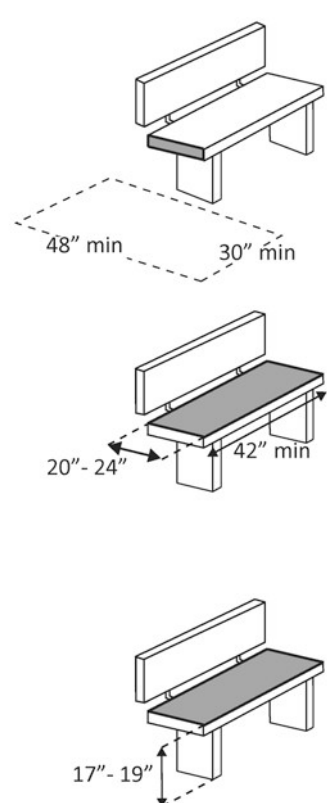
<p>5.28 Is there a clear floor space at least 30 inches wide by at least 48 inches long at the end of the bench and parallel to the short axis of the bench?</p> <p>Is the bench seat at least 42 inches long and no less than 20 inches and no greater than 24 inches deep?</p> <p>Does the bench have back support or is it affixed to a wall?</p> <p>Is the top of the bench seat no less than 17 inches and no greater than 19 inches above the floor? [903]</p>	<p><input checked="" type="checkbox"/> Yes <input type="checkbox"/> No</p> <p>Measurement: 90"</p> <p><input checked="" type="checkbox"/> Yes <input type="checkbox"/> No</p> <p>Measurement: 70"</p> <p><input checked="" type="checkbox"/> Yes <input type="checkbox"/> No</p> <p><input checked="" type="checkbox"/> Yes <input type="checkbox"/> No</p> <p>Measurement: 17"</p>	
---	--	---

Dining Tables Yes No

<p>5.28 Are at least 5 percent, but not less than one, of the dining surfaces for the seating and standing spaces accessible?</p> <p>Is/are the accessible space(s) distributed throughout the facility and located on an accessible route?</p>	<p><input checked="" type="checkbox"/> Yes <input type="checkbox"/> No</p> <p>Total #: 5 Accessible #: 2</p> <p><input checked="" type="checkbox"/> Yes <input type="checkbox"/> No</p>	
--	---	--

ADA Checklist for Existing Facilities - Parks

City of Grand Rapids ADA Transition Plan

Building: Angel of Hope

Location: SE 1st Street

Date: 10/1/19

Evaluated By: Dom DeGuseppi

Priority 5 - Parks

5.1 Is there at least one route from site arrival points (parking, passenger loading zones, public sidewalks and public transportation stops) that does not require the use of stairs? [See 2010 ADA Standards for Accessible Design – 206.2.1]

Yes No

If yes, location of route:

Parking Yes No

5.2 If parking is provided for the public, are an adequate number of accessible spaces provided? [208.2]	<input type="checkbox"/> Yes <input checked="" type="checkbox"/> No Total #: Accessible #:	Total Spaces	Accessible Spaces	Street parking
		1 - 25	1	
		26 - 50	2	
		51 - 75	3	
		76 - 100	4	
		100+ see 2010 Standards 208.2		

5.3 Are accessible spaces at least 8 feet wide with an access aisle at least 8 feet wide? [502.2, 502.3]

Yes No

Measurement:

Note: Two spaces may share an access aisle. Check state/local requirements;

ADA Checklist for Existing Facilities - Parks

some specify that each space have its own aisle.

5.4 Are the access aisles marked with signage and surface painting so as to discourage parking in them?
[502.3.3]

Note: The marking method and color may be addressed by state/local requirements.

Yes No

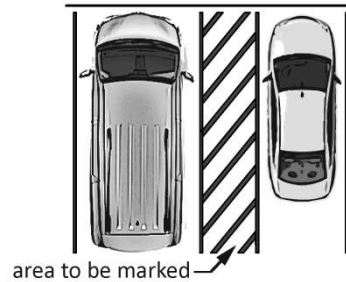

5.5 Is the slope of the accessible parking spaces and access aisles no steeper than 1:48 in all directions?
[502.4]

Yes No

Measurement:
NA

5.6 Do the access aisles adjoin an accessible route?
[502.3]

Yes No

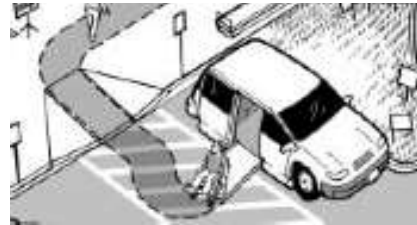

5.7 Are accessible spaces identified with a sign that includes the International Symbol of Accessibility?

Is the bottom of the sign at least 60 inches and not greater than 66 inches above the ground?
[502.6]

Yes No

Yes No

Measurement:

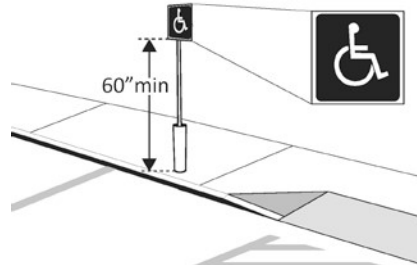

5.8 Of the total parking spaces, are the accessible spaces located on the closest accessible route to the accessible entrance(s)?
[208.3.1]

Yes No

Exterior Accessible Route

5.9 Is the route stable, firm and slip-resistant? [302.1] Yes No

5.10 Is the route at least 36 inches wide? [403.5.1] Yes No
Measurement: **8'**

Note: The accessible route can narrow to 32 inches min. for a max. of 24 inches. These narrower portions of the route must be at least 48 inches from each other.

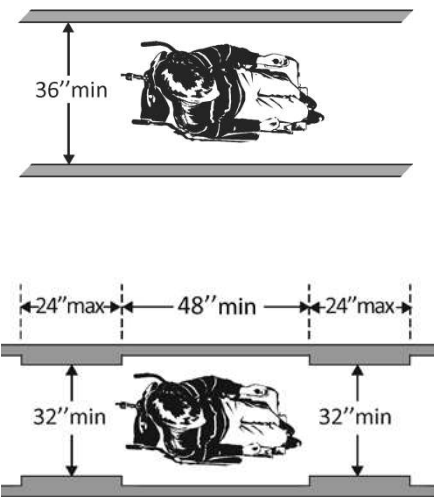

5.11 If the route is greater than 200 feet in length and less than 60 inches wide, is there a passing space no less than 60 x 60 inches? [403.5.3] Yes No
Measurement: **NA**

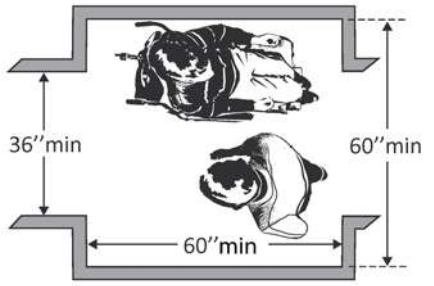

5.12 If there are grates or openings on the route, are the openings no larger than 1/2 inches? [403.5.3] If the route is greater than 200 feet in length and less than 60 inches wide, is there a passing space no less than 60 x 60 inches?

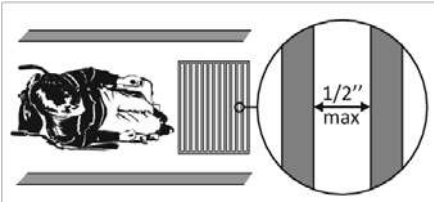

ADA Checklist for Existing Facilities - Parks

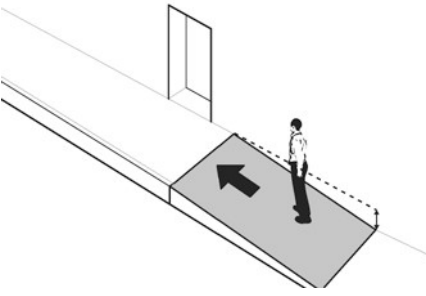
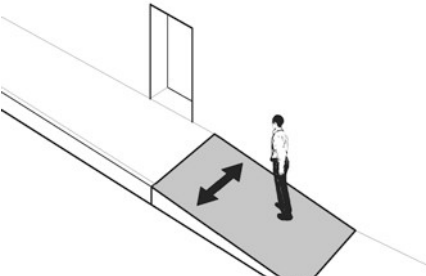
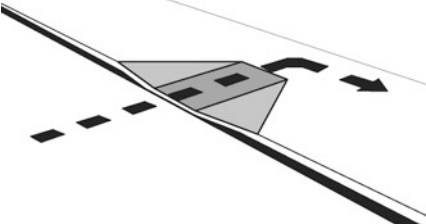
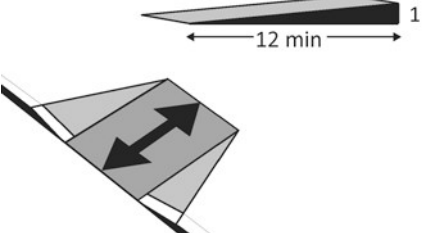
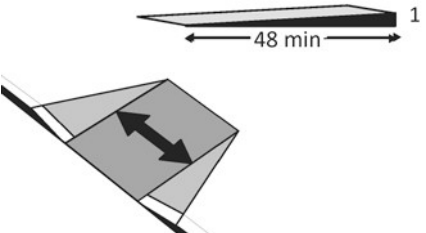
<p>5.13 Is the running slope no steeper than 1:20, i.e. for every inch of height change there are at least 20 inches of route run? [403.3]</p> <p>Note: If the running slope is steeper than 1:20, treat as a ramp and add features such as edge protection and handrails.</p>	<p><input type="checkbox"/> Yes <input checked="" type="checkbox"/> No</p> <p>Measurement: 6.4%</p>		
<p>5.14 Is the cross slope no steeper than 1:48? [403.3]</p>	<p><input type="checkbox"/> Yes <input checked="" type="checkbox"/> No</p> <p>Measurement: 3%</p>		
<p>Curb Ramps <input checked="" type="checkbox"/> Yes <input type="checkbox"/> No</p>			
<p>5.15 If the accessible route crosses a curb, is there a curb ramp? [402.2]</p>	<p><input checked="" type="checkbox"/> Yes <input type="checkbox"/> No</p>		
<p>5.16 Is the running slope of the curb ramp no steeper than 1:12, i.e. for every inch of height change there are at least 12 inches of curb ramp run? [406.1, 405.2]</p>	<p><input checked="" type="checkbox"/> Yes <input type="checkbox"/> No</p> <p>Measurement: 7.9%</p>		
<p>5.17 Is the cross slope of the curb ramp, excluding flares, no steeper than 1:48? [406.1, 405.3]</p>	<p><input checked="" type="checkbox"/> Yes <input type="checkbox"/> No</p> <p>Measurement: 1.2%</p>		

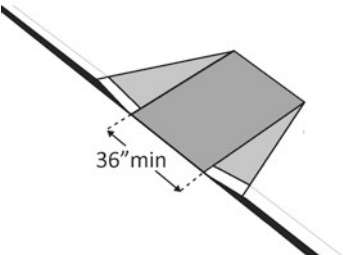
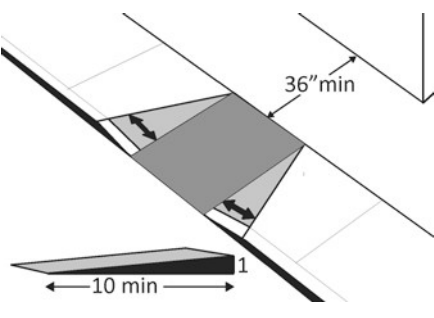
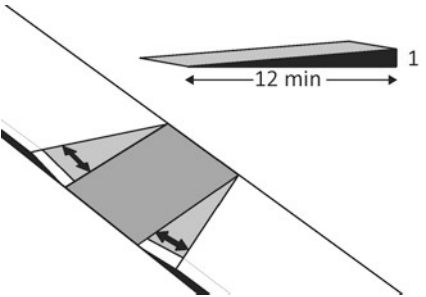
<p>5.18 Is the curb ramp, excluding flares, at least 36 inches wide? [406.1, 405.5]</p>	<p><input checked="" type="checkbox"/> Yes <input type="checkbox"/> No</p> <p>Measurement: 48"</p>		
<p>5.19 At the top of the curb ramp is there a level landing (slope no steeper than 1:48 in all directions) that is at least 36 inches long and at least as wide as the curb ramp? [406.4]</p> <p>If there are curb ramp flares, are the slopes of the flares no steeper than 1:10, i.e. for every inch of height change there are at least 10 inches of flare run? [406.3]</p>	<p><input type="checkbox"/> Yes <input checked="" type="checkbox"/> No</p> <p>Measurement:</p> <p><input type="checkbox"/> Yes <input checked="" type="checkbox"/> No</p> <p>Measurement:</p>		<p>No landing</p>
<p>5.20 If the landing at the top is less than 36 inches long, are there curb ramp flares? [406.4]</p> <p>Are the slopes of the flares no greater than 1:12, i.e. for every inch of height change there are at least 12 inches of flare run? [406.4]</p>	<p><input type="checkbox"/> Yes <input checked="" type="checkbox"/> No</p> <p><input type="checkbox"/> Yes <input checked="" type="checkbox"/> No</p> <p>Measurement:</p>		
<p>Accessible Play Components <input type="checkbox"/> Yes <input checked="" type="checkbox"/> No</p>			
<p>5.21 <u>Ground Level Play Components</u> Is there an accessible route to at least one of each type of ground level play component?</p> <p>Notes:</p> <ol style="list-style-type: none"> 1. A play component is an element designed to generate play, socialization and learning. 2. Ground level play components are components that can be approached and exited at 	<p><input type="checkbox"/> Yes <input type="checkbox"/> No</p>		

ADA Checklist for Existing Facilities - Parks

<p>ground level. Examples include rockers, swings, diggers and stand-alone slides.</p>			
<p>5.22 <u>Elevated Play Components</u> Are there any accessible elevated play components? If so, is there an accessible route to the components?</p>	<p><input type="checkbox"/> Yes <input type="checkbox"/> No <input type="checkbox"/> Yes <input type="checkbox"/> No</p>		
<p>5.23 Is the vertical clearance of the accessible route at least 80 inches above the ground surface? Note: Objects below 80 inches may not protrude into the accessible route.</p>	<p><input type="checkbox"/> Yes <input type="checkbox"/> No</p>		
<p>Pavilion <input type="checkbox"/> Yes <input checked="" type="checkbox"/> No</p>			
<p>5.24 Is there an accessible route that is stable, firm and slip-resistant? [302.1]</p>	<p><input type="checkbox"/> Yes <input type="checkbox"/> No</p>		
<p>5.25 Is the route at least 36 inches wide? [403.5.1]</p>	<p><input type="checkbox"/> Yes <input type="checkbox"/> No</p>		
<p>5.26 Is the running slope no steeper than 1:20, i.e. for every inch of height change there are at least 20 inches of route run? [403.3] Note: If the running slope is steeper than 1:20, treat as a ramp and add features such as edge protection and handrails.</p>	<p><input type="checkbox"/> Yes <input type="checkbox"/> No Measurement:</p>		

ADA Checklist for Existing Facilities - Parks

<p>5.27 Is the cross slope no steeper than 1:48? [403.3]</p>	<p><input type="checkbox"/> Yes <input type="checkbox"/> No</p> <p>Measurement:</p>	
---	---	--

Benches Yes No

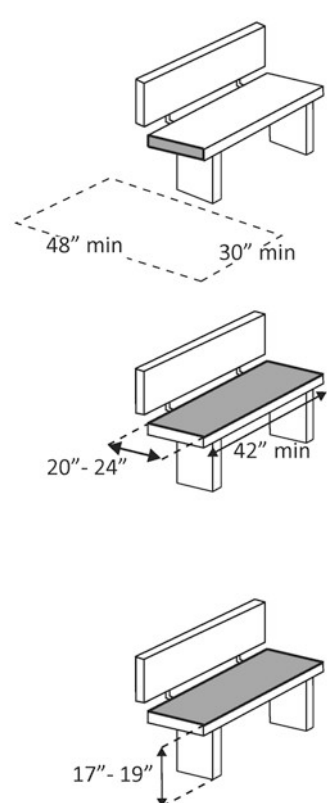
<p>5.28 Is there a clear floor space at least 30 inches wide by at least 48 inches long at the end of the bench and parallel to the short axis of the bench?</p> <p>Is the bench seat at least 42 inches long and no less than 20 inches and no greater than 24 inches deep?</p> <p>Does the bench have back support or is it affixed to a wall?</p> <p>Is the top of the bench seat no less than 17 inches and no greater than 19 inches above the floor? [903]</p>	<p><input checked="" type="checkbox"/> Yes <input type="checkbox"/> No</p> <p>Measurement:</p> <p><input type="checkbox"/> Yes <input checked="" type="checkbox"/> No</p> <p>Measurement: 14.5"</p> <p><input checked="" type="checkbox"/> Yes <input type="checkbox"/> No</p> <p><input type="checkbox"/> Yes <input checked="" type="checkbox"/> No</p> <p>Measurement: 16"</p>		<p>One bench does not have back support Two hanging benches</p>
---	---	---	---

Dining Tables Yes No

<p>5.28 Are at least 5 percent, but not less than one, of the dining surfaces for the seating and standing spaces accessible?</p> <p>Is/are the accessible space(s) distributed throughout the facility and located on an accessible route?</p>	<p><input type="checkbox"/> Yes <input checked="" type="checkbox"/> No</p> <p>Total #: 1 Accessible #: 0</p> <p><input type="checkbox"/> Yes <input checked="" type="checkbox"/> No</p>	
--	---	--

ADA Checklist for Existing Facilities - Parks

City of Grand Rapids ADA Transition Plan

Building: Blandin Beach

Location: NW 10th Ave

Date: 10/8/19

Evaluated By: Dom DeGuseppi

Priority 5 - Parks

5.1 Is there at least one route from site arrival points (parking, passenger loading zones, public sidewalks and public transportation stops) that does not require the use of stairs?
[See 2010 ADA Standards for Accessible Design – 206.2.1]

Yes No

If yes, location of route:

Parking Yes No

5.2 If parking is provided for the public, are an adequate number of accessible spaces provided?
[208.2]

Yes No

Total #: **26**
Accessible #: **1**

Total Spaces	Accessible Spaces
1 - 25	1
26 - 50	2
51 - 75	3
76 - 100	4
100+ see 2010 Standards 208.2	

5.3 Are accessible spaces at least 8 feet wide with an access aisle at least 8 feet wide?
[502.2, 502.3]



Yes No

Measurement:
10'

Note: Two spaces may share an access aisle. Check state/local requirements;

No painted aisle
Parking space is wide enough

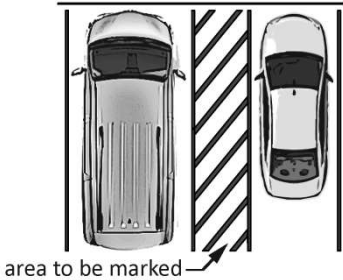
ADA Checklist for Existing Facilities - Parks

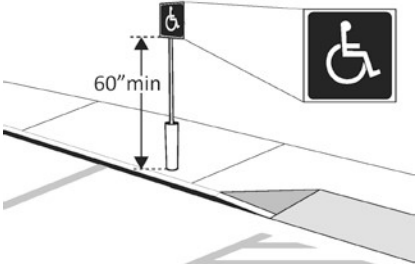
	some specify that each space have its own aisle.		
<p>5.4 Are the access aisles marked with signage and surface painting so as to discourage parking in them? [502.3.3]</p> <p>Note: The marking method and color may be addressed by state/local requirements.</p>	<p><input type="checkbox"/> Yes <input checked="" type="checkbox"/> No</p>		
<p>5.5 Is the slope of the accessible parking spaces and access aisles no steeper than 1:48 in all directions? [502.4]</p>	<p><input type="checkbox"/> Yes <input checked="" type="checkbox"/> No</p> <p>Measurement: 3.5%</p>		
<p>5.6 Do the access aisles adjoin an accessible route? [502.3]</p>	<p><input checked="" type="checkbox"/> Yes <input type="checkbox"/> No</p>		
<p>5.7 Are accessible spaces identified with a sign that includes the International Symbol of Accessibility?</p> <p>Is the bottom of the sign at least 60 inches and not greater than 66 inches above the ground? [502.6]</p>	<p><input checked="" type="checkbox"/> Yes <input type="checkbox"/> No</p> <p><input type="checkbox"/> Yes <input checked="" type="checkbox"/> No</p> <p>Measurement: 85"</p>		
<p>5.8 Of the total parking spaces, are the accessible spaces located on the closest accessible route to the accessible entrance(s)? [208.3.1]</p>	<p><input checked="" type="checkbox"/> Yes <input type="checkbox"/> No</p>		

Exterior Accessible Route

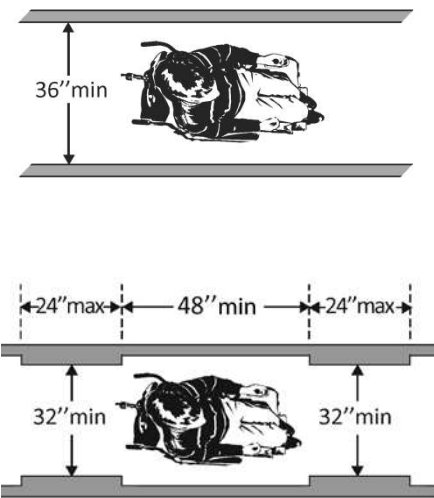
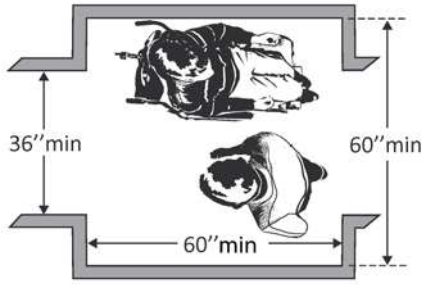
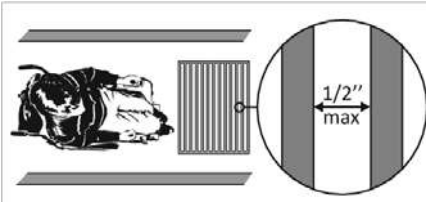
<p>5.9 Is the route stable, firm and slip-resistant? [302.1]</p>	<p><input checked="" type="checkbox"/> Yes <input type="checkbox"/> No</p>	
<p>5.10 Is the route at least 36 inches wide? [403.5.1]</p> <p>Note: The accessible route can narrow to 32 inches min. for a max. of 24 inches. These narrower portions of the route must be at least 48 inches from each other.</p>	<p><input checked="" type="checkbox"/> Yes <input type="checkbox"/> No</p> <p>Measurement: 46"</p>	
<p>5.11 If the route is greater than 200 feet in length and less than 60 inches wide, is there a passing space no less than 60 x 60 inches? [403.5.3]</p>	<p><input type="checkbox"/> Yes <input checked="" type="checkbox"/> No</p> <p>Measurement: NA</p>	
<p>5.12 If there are grates or openings on the route, are the openings no larger than 1/2 inches?</p>	<p>If the route is greater than 200 feet in length and less than 60 inches wide, is there a passing space no less than 60 x 60 inches? [403.5.3]</p>	

ADA Checklist for Existing Facilities - Parks

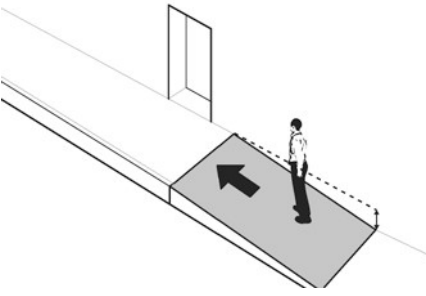
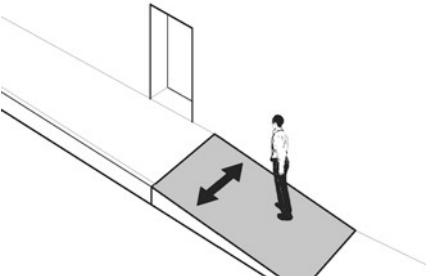
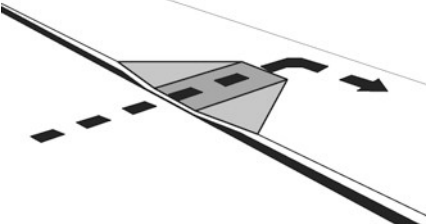
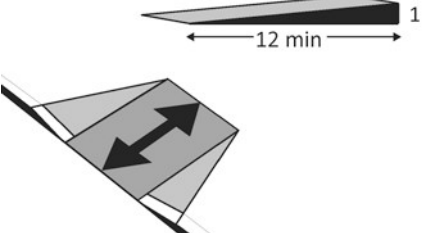
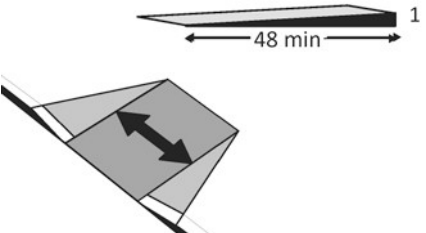
<p>5.13 Is the running slope no steeper than 1:20, i.e. for every inch of height change there are at least 20 inches of route run? [403.3]</p> <p>Note: If the running slope is steeper than 1:20, treat as a ramp and add features such as edge protection and handrails.</p>	<p><input checked="" type="checkbox"/> Yes <input type="checkbox"/> No</p> <p>Measurement: 1.5%</p>		
<p>5.14 Is the cross slope no steeper than 1:48? [403.3]</p>	<p><input checked="" type="checkbox"/> Yes <input type="checkbox"/> No</p> <p>Measurement: 1.1%</p>		
<p>Curb Ramps <input checked="" type="checkbox"/> Yes <input type="checkbox"/> No</p>			
<p>5.15 If the accessible route crosses a curb, is there a curb ramp? [402.2]</p>	<p><input checked="" type="checkbox"/> Yes <input type="checkbox"/> No</p>		
<p>5.16 Is the running slope of the curb ramp no steeper than 1:12, i.e. for every inch of height change there are at least 12 inches of curb ramp run? [406.1, 405.2]</p>	<p><input checked="" type="checkbox"/> Yes <input type="checkbox"/> No</p> <p>Measurement: 6.5%</p>		
<p>5.17 Is the cross slope of the curb ramp, excluding flares, no steeper than 1:48? [406.1, 405.3]</p>	<p><input checked="" type="checkbox"/> Yes <input type="checkbox"/> No</p> <p>Measurement: 1.1%</p>		

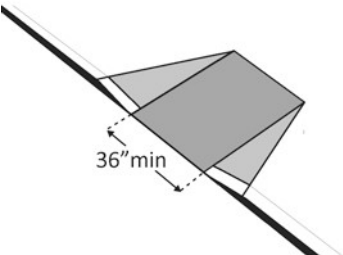
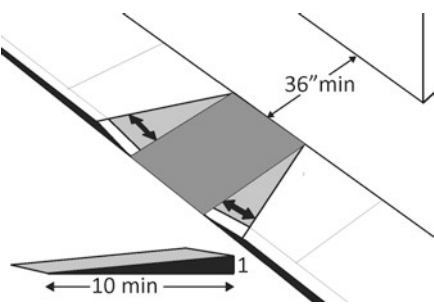
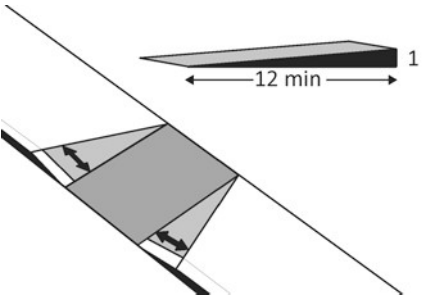
<p>5.18 Is the curb ramp, excluding flares, at least 36 inches wide? [406.1, 405.5]</p>	<p><input checked="" type="checkbox"/> Yes <input type="checkbox"/> No</p> <p>Measurement: 48"</p>		
<p>5.19 At the top of the curb ramp is there a level landing (slope no steeper than 1:48 in all directions) that is at least 36 inches long and at least as wide as the curb ramp? [406.4]</p> <p>If there are curb ramp flares, are the slopes of the flares no steeper than 1:10, i.e. for every inch of height change there are at least 10 inches of flare run? [406.3]</p>	<p><input type="checkbox"/> Yes <input checked="" type="checkbox"/> No</p> <p>Measurement:</p> <p><input type="checkbox"/> Yes <input checked="" type="checkbox"/> No</p> <p>Measurement:</p>		
<p>5.20 If the landing at the top is less than 36 inches long, are there curb ramp flares? [406.4]</p> <p>Are the slopes of the flares no greater than 1:12, i.e. for every inch of height change there are at least 12 inches of flare run? [406.4]</p>	<p><input type="checkbox"/> Yes <input checked="" type="checkbox"/> No</p> <p><input type="checkbox"/> Yes <input checked="" type="checkbox"/> No</p> <p>Measurement:</p>		
<p>Accessible Play Components <input checked="" type="checkbox"/> Yes <input type="checkbox"/> No</p>			
<p>5.21 <u>Ground Level Play Components</u> Is there an accessible route to at least one of each type of ground level play component? [406.4]</p> <p>Notes:</p> <ol style="list-style-type: none"> 1. A play component is an element designed to generate play, socialization and learning. 2. Ground level play components are components that can be approached and exited at 	<p><input checked="" type="checkbox"/> Yes <input type="checkbox"/> No</p>		

ADA Checklist for Existing Facilities - Parks

<p>ground level. Examples include rockers, swings, diggers and stand-alone slides.</p>			
<p>5.22 <u>Elevated Play Components</u> Are there any accessible elevated play components?</p> <p>If so, is there an accessible route to the components?</p>	<p><input type="checkbox"/> Yes <input checked="" type="checkbox"/> No</p> <p><input type="checkbox"/> Yes <input checked="" type="checkbox"/> No</p>		
<p>5.23 Is the vertical clearance of the accessible route at least 80 inches above the ground surface?</p> <p>Note: Objects below 80 inches may not protrude into the accessible route.</p>	<p><input checked="" type="checkbox"/> Yes <input type="checkbox"/> No</p>		
<p>Pavilion <input checked="" type="checkbox"/> Yes <input type="checkbox"/> No</p>			
<p>5.24 Is there an accessible route that is stable, firm and slip-resistant? [302.1]</p>	<p><input checked="" type="checkbox"/> Yes <input type="checkbox"/> No</p>		
<p>5.25 Is the route at least 36 inches wide? [403.5.1]</p>	<p><input checked="" type="checkbox"/> Yes <input type="checkbox"/> No</p>		
<p>5.26 Is the running slope no steeper than 1:20, i.e. for every inch of height change there are at least 20 inches of route run? [403.3]</p> <p>Note: If the running slope is steeper than 1:20, treat as a ramp and add features such as edge protection and handrails.</p>	<p><input checked="" type="checkbox"/> Yes <input type="checkbox"/> No</p> <p>Measurement: 2.2%</p>		

ADA Checklist for Existing Facilities - Parks

<p>5.27 Is the cross slope no steeper than 1:48? [403.3]</p>	<p><input checked="" type="checkbox"/> Yes <input type="checkbox"/> No</p> <p>Measurement: 1.1%</p>	
---	--	--

Benches Yes No

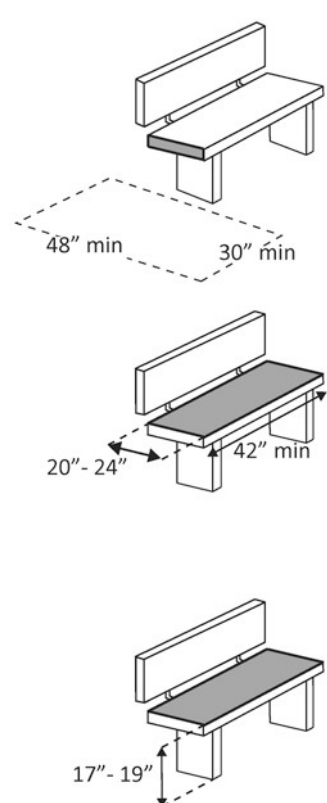
<p>5.28 Is there a clear floor space at least 30 inches wide by at least 48 inches long at the end of the bench and parallel to the short axis of the bench?</p> <p>Is the bench seat at least 42 inches long and no less than 20 inches and no greater than 24 inches deep?</p> <p>Does the bench have back support or is it affixed to a wall?</p> <p>Is the top of the bench seat no less than 17 inches and no greater than 19 inches above the floor? [903]</p>	<p><input checked="" type="checkbox"/> Yes <input type="checkbox"/> No</p> <p>Measurement: 70"</p> <p><input checked="" type="checkbox"/> Yes <input type="checkbox"/> No</p> <p>Measurement: 17"</p>	
---	---	---

Dining Tables Yes No

<p>5.28 Are at least 5 percent, but not less than one, of the dining surfaces for the seating and standing spaces accessible?</p> <p>Is/are the accessible space(s) distributed throughout the facility and located on an accessible route?</p>	<p><input checked="" type="checkbox"/> Yes <input type="checkbox"/> No</p> <p>Total #: 5 Accessible #: 1</p> <p><input type="checkbox"/> Yes <input checked="" type="checkbox"/> No</p>	
--	---	--

ADA Checklist for Existing Facilities - Parks

City of Grand Rapids ADA Transition Plan

Building: Central School

Location: _____

Date: 10/9/19

Evaluated By: Dom DeGuseppi

Priority 5 - Parks

5.1 Is there at least one route from site arrival points (parking, passenger loading zones, public sidewalks and public transportation stops) that does not require the use of stairs? [See 2010 ADA Standards for Accessible Design – 206.2.1]

Yes No

If yes, location of route:

Parking Yes No

5.2 If parking is provided for the public, are an adequate number of accessible spaces provided? [208.2]

Yes No

Total #: **48**
Accessible #: **2**

Total Spaces	Accessible Spaces
1 - 25	1
26 - 50	2
51 - 75	3
76 - 100	4
100+ see 2010 Standards 208.2	



5.3 Are accessible spaces at least 8 feet wide with an access aisle at least 8 feet wide? [502.2, 502.3]

Yes No

Measurement: **8'**

Note: Two spaces may share an access aisle. Check state/local requirements;

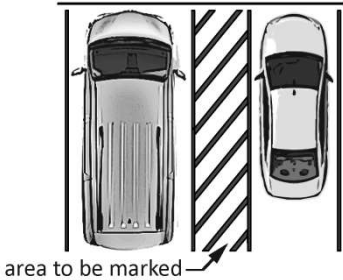
ADA Checklist for Existing Facilities - Parks

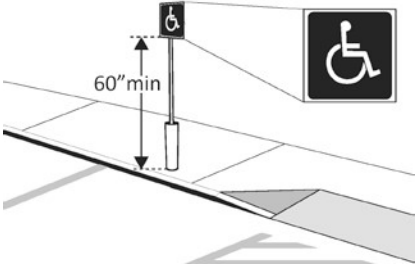
	some specify that each space have its own aisle.		
<p>5.4 Are the access aisles marked with signage and surface painting so as to discourage parking in them? [502.3.3]</p> <p>Note: The marking method and color may be addressed by state/local requirements.</p>	<p><input checked="" type="checkbox"/> Yes <input type="checkbox"/> No</p>		
<p>5.5 Is the slope of the accessible parking spaces and access aisles no steeper than 1:48 in all directions? [502.4]</p>	<p><input checked="" type="checkbox"/> Yes <input type="checkbox"/> No</p> <p>Measurement: 2.3%</p>		
<p>5.6 Do the access aisles adjoin an accessible route? [502.3]</p>	<p><input checked="" type="checkbox"/> Yes <input type="checkbox"/> No</p>		
<p>5.7 Are accessible spaces identified with a sign that includes the International Symbol of Accessibility?</p> <p>Is the bottom of the sign at least 60 inches and not greater than 66 inches above the ground? [502.6]</p>	<p><input checked="" type="checkbox"/> Yes <input type="checkbox"/> No</p> <p><input type="checkbox"/> Yes <input checked="" type="checkbox"/> No</p> <p>Measurement:</p>		<p>One sign height is to short</p>
<p>5.8 Of the total parking spaces, are the accessible spaces located on the closest accessible route to the accessible entrance(s)? [208.3.1]</p>	<p><input checked="" type="checkbox"/> Yes <input type="checkbox"/> No</p>		

Exterior Accessible Route

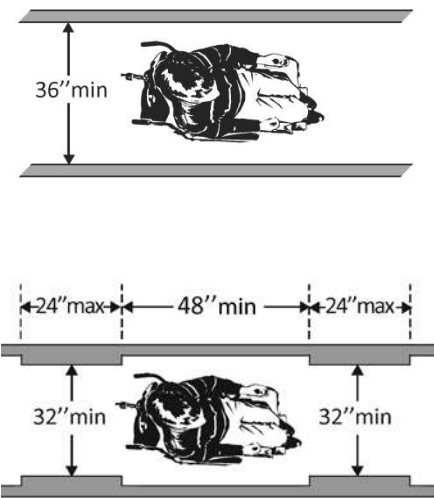
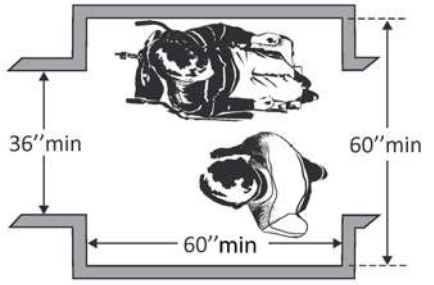
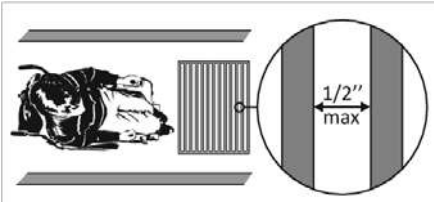
<p>5.9 Is the route stable, firm and slip-resistant? [302.1]</p>	<p><input checked="" type="checkbox"/> Yes <input type="checkbox"/> No</p>		
<p>5.10 Is the route at least 36 inches wide? [403.5.1]</p> <p>Note: The accessible route can narrow to 32 inches min. for a max. of 24 inches. These narrower portions of the route must be at least 48 inches from each other.</p>	<p><input checked="" type="checkbox"/> Yes <input type="checkbox"/> No</p> <p>Measurement: 8'</p>		<p>Sidewalk around Central school is 8' wide</p>
<p>5.11 If the route is greater than 200 feet in length and less than 60 inches wide, is there a passing space no less than 60 x 60 inches? [403.5.3]</p>	<p><input type="checkbox"/> Yes <input checked="" type="checkbox"/> No</p> <p>Measurement: NA</p>		
<p>5.12 If there are grates or openings on the route, are the openings no larger than 1/2 inches?</p>	<p>If the route is greater than 200 feet in length and less than 60 inches wide, is there a passing space no less than 60 x 60 inches? [403.5.3]</p>		

ADA Checklist for Existing Facilities - Parks

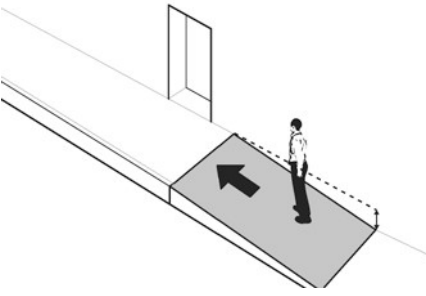
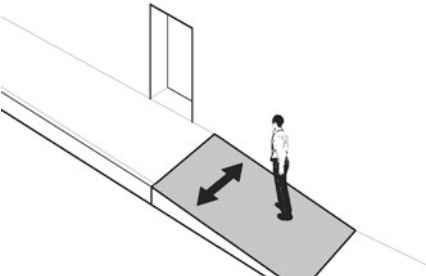
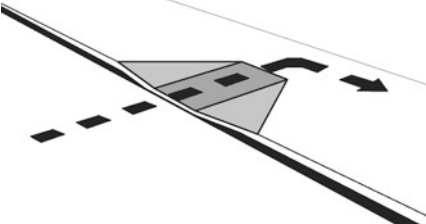
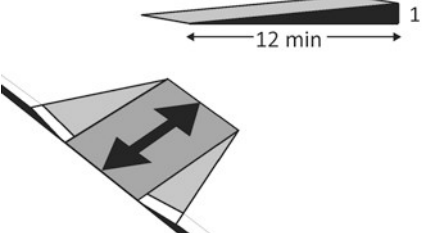
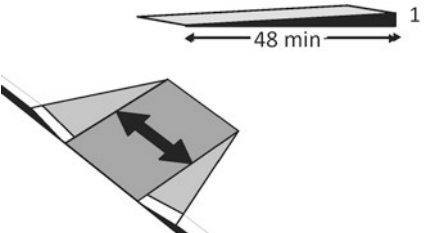
<p>5.13 Is the running slope no steeper than 1:20, i.e. for every inch of height change there are at least 20 inches of route run? [403.3]</p> <p>Note: If the running slope is steeper than 1:20, treat as a ramp and add features such as edge protection and handrails.</p>	<p><input checked="" type="checkbox"/> Yes <input type="checkbox"/> No</p> <p>Measurement: 4.8%</p>		
<p>5.14 Is the cross slope no steeper than 1:48? [403.3]</p>	<p><input type="checkbox"/> Yes <input checked="" type="checkbox"/> No</p> <p>Measurement:</p>		
<p>Curb Ramps <input checked="" type="checkbox"/> Yes <input type="checkbox"/> No</p>			
<p>5.15 If the accessible route crosses a curb, is there a curb ramp? [402.2]</p>	<p><input checked="" type="checkbox"/> Yes <input type="checkbox"/> No</p>		
<p>5.16 Is the running slope of the curb ramp no steeper than 1:12, i.e. for every inch of height change there are at least 12 inches of curb ramp run? [406.1, 405.2]</p>	<p><input checked="" type="checkbox"/> Yes <input type="checkbox"/> No</p> <p>Measurement: 2.5%</p>		
<p>5.17 Is the cross slope of the curb ramp, excluding flares, no steeper than 1:48? [406.1, 405.3]</p>	<p><input checked="" type="checkbox"/> Yes <input type="checkbox"/> No</p> <p>Measurement: .8%</p>		

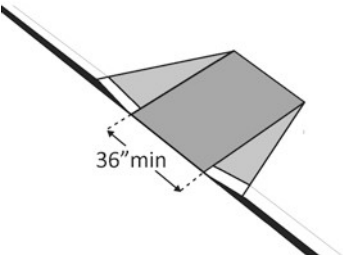
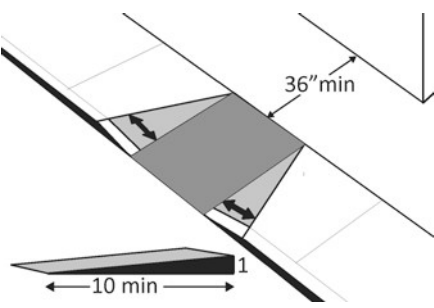
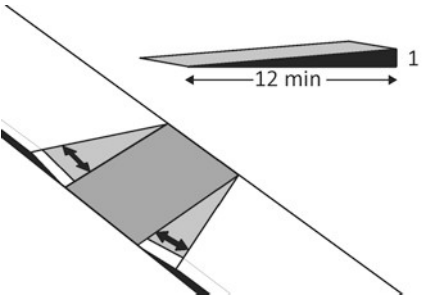
<p>5.18 Is the curb ramp, excluding flares, at least 36 inches wide? [406.1, 405.5]</p>	<p><input checked="" type="checkbox"/> Yes <input type="checkbox"/> No</p> <p>Measurement: 36"</p>		
<p>5.19 At the top of the curb ramp is there a level landing (slope no steeper than 1:48 in all directions) that is at least 36 inches long and at least as wide as the curb ramp? [406.4]</p> <p>If there are curb ramp flares, are the slopes of the flares no steeper than 1:10, i.e. for every inch of height change there are at least 10 inches of flare run? [406.3]</p>	<p><input type="checkbox"/> Yes <input checked="" type="checkbox"/> No</p> <p>Measurement:</p> <p><input type="checkbox"/> Yes <input checked="" type="checkbox"/> No</p> <p>Measurement:</p>		<p>No Landing</p>
<p>5.20 If the landing at the top is less than 36 inches long, are there curb ramp flares? [406.4]</p> <p>Are the slopes of the flares no greater than 1:12, i.e. for every inch of height change there are at least 12 inches of flare run? [406.4]</p>	<p><input type="checkbox"/> Yes <input checked="" type="checkbox"/> No</p> <p><input type="checkbox"/> Yes <input checked="" type="checkbox"/> No</p> <p>Measurement:</p>		
<p>Accessible Play Components <input type="checkbox"/> Yes <input checked="" type="checkbox"/> No</p>			
<p>5.21 <u>Ground Level Play Components</u> Is there an accessible route to at least one of each type of ground level play component? [406.4]</p> <p>Notes:</p> <ol style="list-style-type: none"> 1. A play component is an element designed to generate play, socialization and learning. 2. Ground level play components are components that can be approached and exited at 	<p><input type="checkbox"/> Yes <input type="checkbox"/> No</p>		

ADA Checklist for Existing Facilities - Parks

<p>ground level. Examples include rockers, swings, diggers and stand-alone slides.</p>			
<p>5.22 <u>Elevated Play Components</u> Are there any accessible elevated play components? If so, is there an accessible route to the components?</p>	<p><input type="checkbox"/> Yes <input type="checkbox"/> No <input type="checkbox"/> Yes <input type="checkbox"/> No</p>		
<p>5.23 Is the vertical clearance of the accessible route at least 80 inches above the ground surface? Note: Objects below 80 inches may not protrude into the accessible route.</p>	<p><input type="checkbox"/> Yes <input type="checkbox"/> No</p>		
<p>Pavilion <input type="checkbox"/> Yes <input checked="" type="checkbox"/> No</p>			
<p>5.24 Is there an accessible route that is stable, firm and slip-resistant? [302.1]</p>	<p><input type="checkbox"/> Yes <input type="checkbox"/> No</p>		
<p>5.25 Is the route at least 36 inches wide? [403.5.1]</p>	<p><input type="checkbox"/> Yes <input type="checkbox"/> No</p>		
<p>5.26 Is the running slope no steeper than 1:20, i.e. for every inch of height change there are at least 20 inches of route run? [403.3] Note: If the running slope is steeper than 1:20, treat as a ramp and add features such as edge protection and handrails.</p>	<p><input type="checkbox"/> Yes <input type="checkbox"/> No Measurement:</p>		

ADA Checklist for Existing Facilities - Parks

<p>5.27 Is the cross slope no steeper than 1:48? [403.3]</p>	<p><input type="checkbox"/> Yes <input type="checkbox"/> No</p> <p>Measurement:</p>	
---	---	--

Benches Yes No

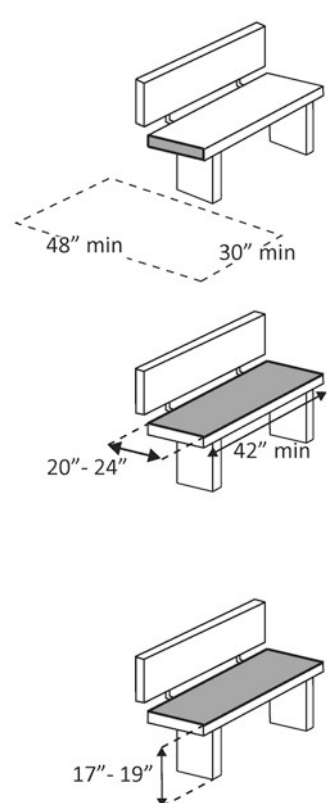
<p>5.28 Is there a clear floor space at least 30 inches wide by at least 48 inches long at the end of the bench and parallel to the short axis of the bench?</p> <p>Is the bench seat at least 42 inches long and no less than 20 inches and no greater than 24 inches deep?</p> <p>Does the bench have back support or is it affixed to a wall?</p> <p>Is the top of the bench seat no less than 17 inches and no greater than 19 inches above the floor? [903]</p>	<p><input checked="" type="checkbox"/> Yes <input type="checkbox"/> No</p> <p>Measurement:</p> <p><input checked="" type="checkbox"/> Yes <input type="checkbox"/> No</p> <p>Measurement:</p> <p>70"</p> <p><input checked="" type="checkbox"/> Yes <input type="checkbox"/> No</p> <p><input checked="" type="checkbox"/> Yes <input type="checkbox"/> No</p> <p>Measurement:</p> <p>17"</p>	
---	---	---

Dining Tables Yes No

<p>5.28 Are at least 5 percent, but not less than one, of the dining surfaces for the seating and standing spaces accessible?</p> <p>Is/are the accessible space(s) distributed throughout the facility and located on an accessible route?</p>	<p><input type="checkbox"/> Yes <input checked="" type="checkbox"/> No</p> <p>Total #: 3 Accessible #: 0</p> <p><input type="checkbox"/> Yes <input checked="" type="checkbox"/> No</p>	
--	---	--

ADA Checklist for Existing Facilities - Parks

City of Grand Rapids ADA Transition Plan

Building: Crystal Lake Park

Location: _____

Date: 10/8/19

Evaluated By: Dom DeGuseppi

Priority 5 - Parks

5.1 Is there at least one route from site arrival points (parking, passenger loading zones, public sidewalks and public transportation stops) that does not require the use of stairs?
[See 2010 ADA Standards for Accessible Design – 206.2.1]

Yes No

If yes, location of route:

Parking Yes No

5.2 If parking is provided for the public, are an adequate number of accessible spaces provided? [208.2]	<input type="checkbox"/> Yes <input checked="" type="checkbox"/> No	Total #: Accessible #:	Total Spaces	Accessible Spaces	Street side parking
			1 - 25	1	
			26 - 50	2	
			51 - 75	3	
			76 - 100	4	
			100+ see 2010 Standards 208.2		

5.3 Are accessible spaces at least 8 feet wide with an access aisle at least 8 feet wide?
[502.2, 502.3]



Yes No

Measurement:

Note: Two spaces may share an access aisle. Check state/local requirements;

No markings

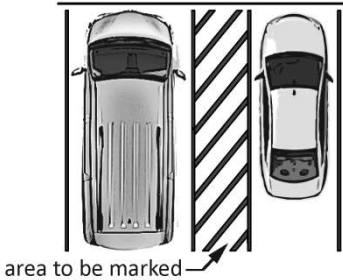
ADA Checklist for Existing Facilities - Parks

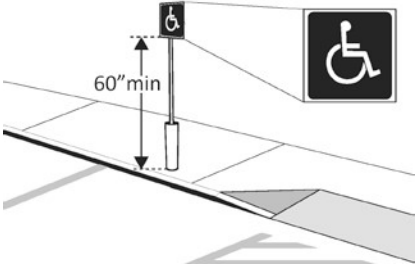
	some specify that each space have its own aisle.		
<p>5.4 Are the access aisles marked with signage and surface painting so as to discourage parking in them? [502.3.3]</p> <p>Note: The marking method and color may be addressed by state/local requirements.</p>	<p><input type="checkbox"/> Yes <input checked="" type="checkbox"/> No</p>		
<p>5.5 Is the slope of the accessible parking spaces and access aisles no steeper than 1:48 in all directions? [502.4]</p>	<p><input type="checkbox"/> Yes <input checked="" type="checkbox"/> No</p> <p>Measurement: NA</p>		
<p>5.6 Do the access aisles adjoin an accessible route? [502.3]</p>	<p><input type="checkbox"/> Yes <input checked="" type="checkbox"/> No</p>		
<p>5.7 Are accessible spaces identified with a sign that includes the International Symbol of Accessibility?</p> <p>Is the bottom of the sign at least 60 inches and not greater than 66 inches above the ground? [502.6]</p>	<p><input type="checkbox"/> Yes <input checked="" type="checkbox"/> No</p> <p><input type="checkbox"/> Yes <input checked="" type="checkbox"/> No</p> <p>Measurement:</p>		
<p>5.8 Of the total parking spaces, are the accessible spaces located on the closest accessible route to the accessible entrance(s)? [208.3.1]</p>	<p><input type="checkbox"/> Yes <input checked="" type="checkbox"/> No</p>		

Exterior Accessible Route

5.9 Is the route stable, firm and slip-resistant?
[302.1] Yes No

5.10 Is the route at least 36 inches wide?
[403.5.1] Yes No
Measurement:
6'

Note: The accessible route can narrow to 32 inches min. for a max. of 24 inches. These narrower portions of the route must be at least 48 inches from each other.

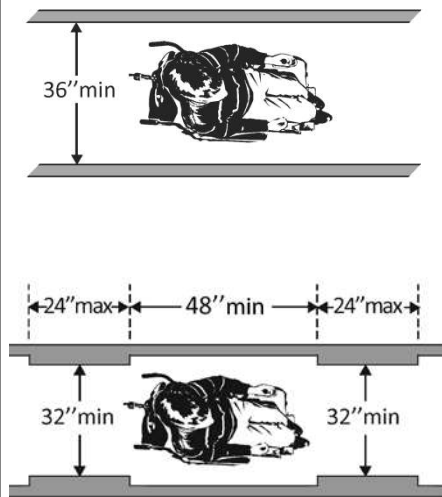

5.11 If the route is greater than 200 feet in length and less than 60 inches wide, is there a passing space no less than 60 x 60 inches?
[403.5.3] Yes No
Measurement:
NA

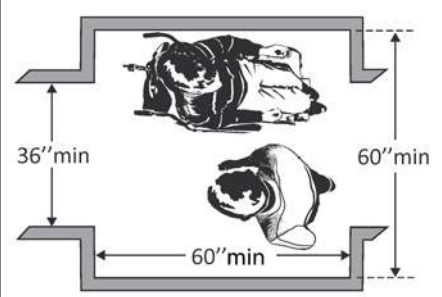

5.12 If there are grates or openings on the route, are the openings no larger than 1/2 inches?
If the route is greater than 200 feet in length and less than 60 inches wide, is there a passing space no less than 60 x 60 inches?
[403.5.3]

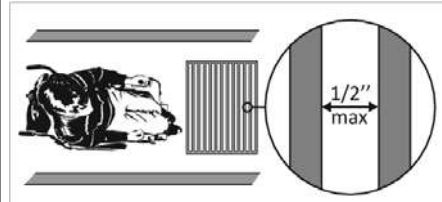

ADA Checklist for Existing Facilities - Parks

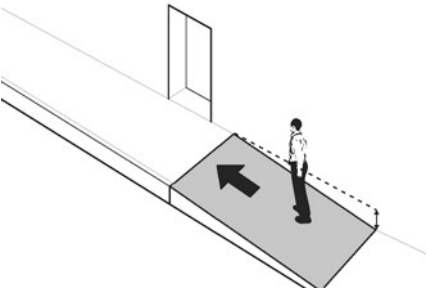
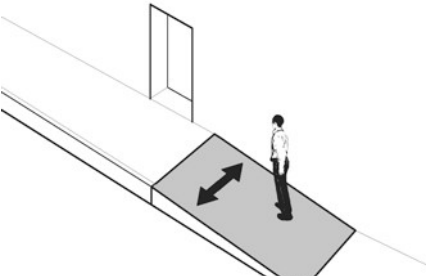
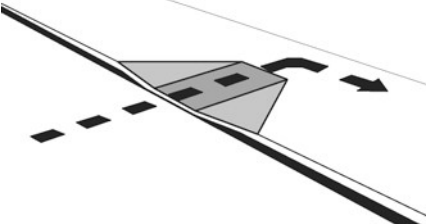
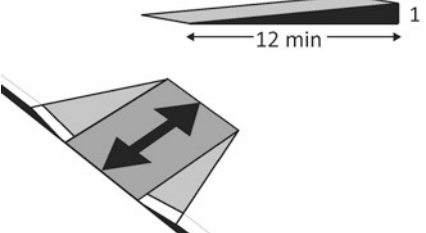
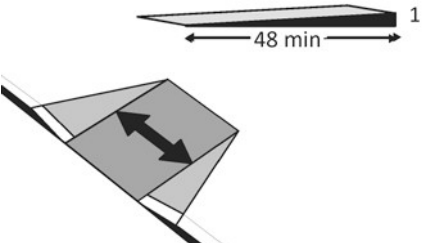
<p>5.13 Is the running slope no steeper than 1:20, i.e. for every inch of height change there are at least 20 inches of route run? [403.3]</p> <p>Note: If the running slope is steeper than 1:20, treat as a ramp and add features such as edge protection and handrails.</p>	<p><input checked="" type="checkbox"/> Yes <input type="checkbox"/> No</p> <p>Measurement: 1.4%</p>		
<p>5.14 Is the cross slope no steeper than 1:48? [403.3]</p>	<p><input checked="" type="checkbox"/> Yes <input type="checkbox"/> No</p> <p>Measurement: .9%</p>		
<p>Curb Ramps <input checked="" type="checkbox"/> Yes <input type="checkbox"/> No</p>			
<p>5.15 If the accessible route crosses a curb, is there a curb ramp? [402.2]</p>	<p><input checked="" type="checkbox"/> Yes <input type="checkbox"/> No</p>		
<p>5.16 Is the running slope of the curb ramp no steeper than 1:12, i.e. for every inch of height change there are at least 12 inches of curb ramp run? [406.1, 405.2]</p>	<p><input checked="" type="checkbox"/> Yes <input type="checkbox"/> No</p> <p>Measurement: 7.9%</p>		
<p>5.17 Is the cross slope of the curb ramp, excluding flares, no steeper than 1:48? [406.1, 405.3]</p>	<p><input checked="" type="checkbox"/> Yes <input type="checkbox"/> No</p> <p>Measurement: .2%</p>		

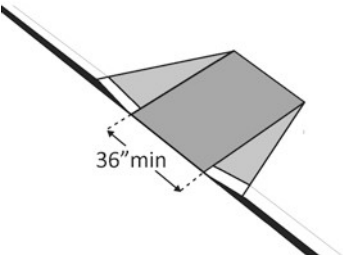
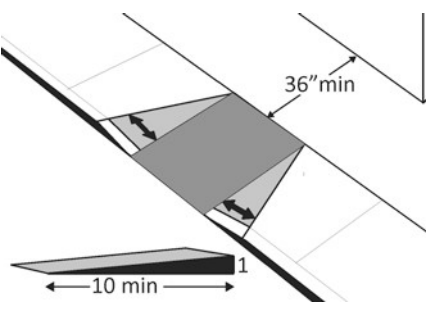
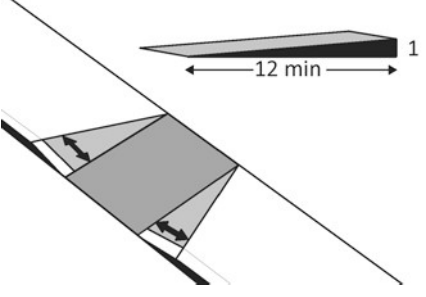
<p>5.18 Is the curb ramp, excluding flares, at least 36 inches wide? [406.1, 405.5]</p>	<p><input checked="" type="checkbox"/> Yes <input type="checkbox"/> No</p> <p>Measurement: 36"</p>		
<p>5.19 At the top of the curb ramp is there a level landing (slope no steeper than 1:48 in all directions) that is at least 36 inches long and at least as wide as the curb ramp? [406.4]</p> <p>If there are curb ramp flares, are the slopes of the flares no steeper than 1:10, i.e. for every inch of height change there are at least 10 inches of flare run? [406.3]</p>	<p><input checked="" type="checkbox"/> Yes <input type="checkbox"/> No</p> <p>Measurement: .6%</p> <p><input type="checkbox"/> Yes <input checked="" type="checkbox"/> No</p> <p>Measurement:</p>		
<p>5.20 If the landing at the top is less than 36 inches long, are there curb ramp flares? [406.4]</p> <p>Are the slopes of the flares no greater than 1:12, i.e. for every inch of height change there are at least 12 inches of flare run? [406.4]</p>	<p><input type="checkbox"/> Yes <input checked="" type="checkbox"/> No</p> <p><input type="checkbox"/> Yes <input checked="" type="checkbox"/> No</p> <p>Measurement:</p>		
<p>Accessible Play Components <input checked="" type="checkbox"/> Yes <input type="checkbox"/> No</p>			
<p>5.21 <u>Ground Level Play Components</u> Is there an accessible route to at least one of each type of ground level play component? [406.4]</p> <p>Notes:</p> <ol style="list-style-type: none"> 1. A play component is an element designed to generate play, socialization and learning. 2. Ground level play components are components that can be approached and exited at 	<p><input checked="" type="checkbox"/> Yes <input type="checkbox"/> No</p>		

ADA Checklist for Existing Facilities - Parks

<p>ground level. Examples include rockers, swings, diggers and stand-alone slides.</p>			
<p>5.22 <u>Elevated Play Components</u> Are there any accessible elevated play components?</p> <p>If so, is there an accessible route to the components?</p>	<p><input type="checkbox"/> Yes <input checked="" type="checkbox"/> No</p> <p><input type="checkbox"/> Yes <input checked="" type="checkbox"/> No</p>		
<p>5.23 Is the vertical clearance of the accessible route at least 80 inches above the ground surface?</p> <p>Note: Objects below 80 inches may not protrude into the accessible route.</p>	<p><input checked="" type="checkbox"/> Yes <input type="checkbox"/> No</p>		
<p>Pavilion <input checked="" type="checkbox"/> Yes <input type="checkbox"/> No</p>			
<p>5.24 Is there an accessible route that is stable, firm and slip-resistant? [302.1]</p>	<p><input checked="" type="checkbox"/> Yes <input type="checkbox"/> No</p>		
<p>5.25 Is the route at least 36 inches wide? [403.5.1]</p>	<p><input checked="" type="checkbox"/> Yes <input type="checkbox"/> No</p>		
<p>5.26 Is the running slope no steeper than 1:20, i.e. for every inch of height change there are at least 20 inches of route run? [403.3]</p> <p>Note: If the running slope is steeper than 1:20, treat as a ramp and add features such as edge protection and handrails.</p>	<p><input checked="" type="checkbox"/> Yes <input type="checkbox"/> No</p> <p>Measurement: 3.3%</p>		

ADA Checklist for Existing Facilities - Parks

<p>5.27 Is the cross slope no steeper than 1:48? [403.3]</p>	<p><input checked="" type="checkbox"/> Yes <input type="checkbox"/> No</p> <p>Measurement: .4%</p>	
---	---	--

Benches Yes No

<p>5.28 Is there a clear floor space at least 30 inches wide by at least 48 inches long at the end of the bench and parallel to the short axis of the bench?</p> <p>Is the bench seat at least 42 inches long and no less than 20 inches and no greater than 24 inches deep?</p> <p>Does the bench have back support or is it affixed to a wall?</p> <p>Is the top of the bench seat no less than 17 inches and no greater than 19 inches above the floor? [903]</p>	<p><input checked="" type="checkbox"/> Yes <input type="checkbox"/> No</p> <p>Measurement: 118"</p> <p><input checked="" type="checkbox"/> Yes <input type="checkbox"/> No</p> <p>Measurement: 70"</p> <p><input checked="" type="checkbox"/> Yes <input type="checkbox"/> No</p> <p><input checked="" type="checkbox"/> Yes <input type="checkbox"/> No</p> <p>Measurement: 17"</p>	
---	---	--

Dining Tables Yes No

<p>5.28 Are at least 5 percent, but not less than one, of the dining surfaces for the seating and standing spaces accessible?</p> <p>Is/are the accessible space(s) distributed throughout the facility and located on an accessible route?</p>	<p><input checked="" type="checkbox"/> Yes <input type="checkbox"/> No</p> <p>Total #: 3 Accessible #: 1</p> <p><input checked="" type="checkbox"/> Yes <input type="checkbox"/> No</p>	
--	---	--

ADA Checklist for Existing Facilities - Parks

City of Grand Rapids ADA Transition Plan

Building: Grussendorf

Location: 7th Ave SW

Date: 10/2/19

Evaluated By: Dom DeGuseppi

Priority 5 - Parks

5.1 Is there at least one route from site arrival points (parking, passenger loading zones, public sidewalks and public transportation stops) that does not require the use of stairs?
[See 2010 ADA Standards for Accessible Design – 206.2.1]

Yes No

If yes, location of route:

Parking Yes No

5.2 If parking is provided for the public, are an adequate number of accessible spaces provided?
[208.2]

Yes No

Total #: **24**
Accessible #: **0**

Total Spaces	Accessible Spaces
1 - 25	1
26 - 50	2
51 - 75	3
76 - 100	4
100+ see 2010 Standards 208.2	

Street side parking is available



5.3 Are accessible spaces at least 8 feet wide with an access aisle at least 8 feet wide?
[502.2, 502.3]

Yes No

Measurement:

Note: Two spaces may share an access aisle. Check state/local requirements;

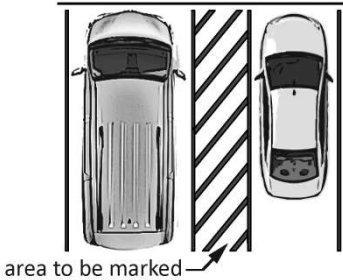
ADA Checklist for Existing Facilities - Parks

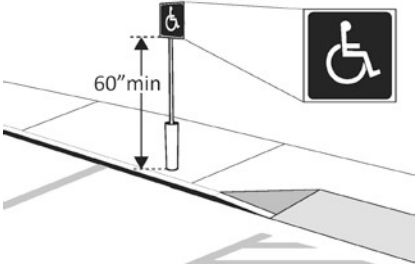
	some specify that each space have its own aisle.		
<p>5.4 Are the access aisles marked with signage and surface painting so as to discourage parking in them? [502.3.3]</p> <p>Note: The marking method and color may be addressed by state/local requirements.</p>	<p><input type="checkbox"/> Yes <input checked="" type="checkbox"/> No</p>		
<p>5.5 Is the slope of the accessible parking spaces and access aisles no steeper than 1:48 in all directions? [502.4]</p>	<p><input type="checkbox"/> Yes <input checked="" type="checkbox"/> No</p> <p>Measurement:</p>		
<p>5.6 Do the access aisles adjoin an accessible route? [502.3]</p>	<p><input type="checkbox"/> Yes <input checked="" type="checkbox"/> No</p>		
<p>5.7 Are accessible spaces identified with a sign that includes the International Symbol of Accessibility?</p> <p>Is the bottom of the sign at least 60 inches and not greater than 66 inches above the ground? [502.6]</p>	<p><input type="checkbox"/> Yes <input checked="" type="checkbox"/> No</p> <p><input type="checkbox"/> Yes <input checked="" type="checkbox"/> No</p> <p>Measurement:</p>		
<p>5.8 Of the total parking spaces, are the accessible spaces located on the closest accessible route to the accessible entrance(s)? [208.3.1]</p>	<p><input type="checkbox"/> Yes <input checked="" type="checkbox"/> No</p>		

Exterior Accessible Route

<p>5.9 Is the route stable, firm and slip-resistant? [302.1]</p>	<p><input checked="" type="checkbox"/> Yes <input type="checkbox"/> No</p>		
<p>5.10 Is the route at least 36 inches wide? [403.5.1]</p> <p>Note: The accessible route can narrow to 32 inches min. for a max. of 24 inches. These narrower portions of the route must be at least 48 inches from each other.</p>	<p><input checked="" type="checkbox"/> Yes <input type="checkbox"/> No</p> <p>Measurement: 48"</p>		
<p>5.11 If the route is greater than 200 feet in length and less than 60 inches wide, is there a passing space no less than 60 x 60 inches? [403.5.3]</p>	<p><input type="checkbox"/> Yes <input checked="" type="checkbox"/> No</p> <p>Measurement:</p>		<p>No passing space</p>
<p>5.12 If there are grates or openings on the route, are the openings no larger than 1/2 inches?</p>	<p>If the route is greater than 200 feet in length and less than 60 inches wide, is there a passing space no less than 60 x 60 inches? [403.5.3]</p>		

ADA Checklist for Existing Facilities - Parks

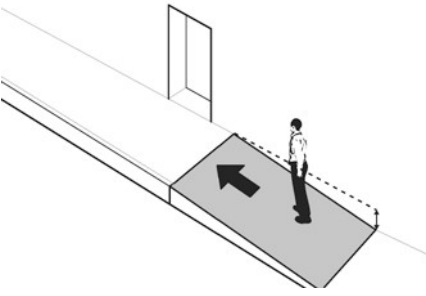
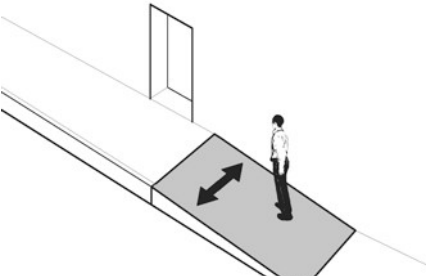
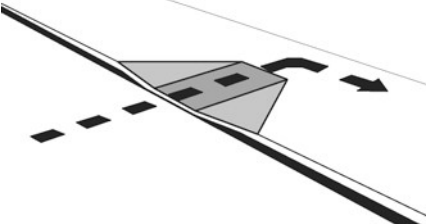
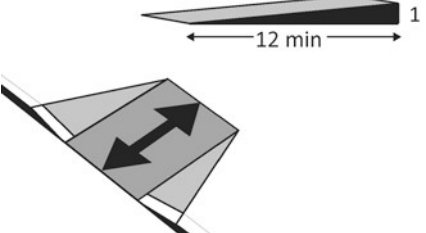
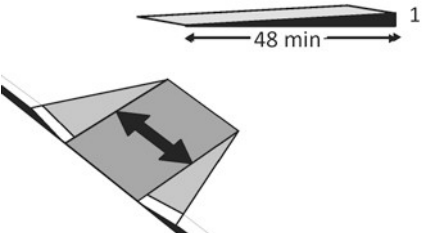
<p>5.13 Is the running slope no steeper than 1:20, i.e. for every inch of height change there are at least 20 inches of route run? [403.3]</p> <p>Note: If the running slope is steeper than 1:20, treat as a ramp and add features such as edge protection and handrails.</p>	<p><input checked="" type="checkbox"/> Yes <input type="checkbox"/> No</p> <p>Measurement: 1.2%</p>		
<p>5.14 Is the cross slope no steeper than 1:48? [403.3]</p>	<p><input checked="" type="checkbox"/> Yes <input type="checkbox"/> No</p> <p>Measurement: 1.5%</p>		
<p>Curb Ramps <input checked="" type="checkbox"/> Yes <input type="checkbox"/> No</p>			
<p>5.15 If the accessible route crosses a curb, is there a curb ramp? [402.2]</p>	<p><input checked="" type="checkbox"/> Yes <input type="checkbox"/> No</p>		
<p>5.16 Is the running slope of the curb ramp no steeper than 1:12, i.e. for every inch of height change there are at least 12 inches of curb ramp run? [406.1, 405.2]</p>	<p><input type="checkbox"/> Yes <input checked="" type="checkbox"/> No</p> <p>Measurement: 7.2%</p>		
<p>5.17 Is the cross slope of the curb ramp, excluding flares, no steeper than 1:48? [406.1, 405.3]</p>	<p><input type="checkbox"/> Yes <input checked="" type="checkbox"/> No</p> <p>Measurement: 2.6%</p>		

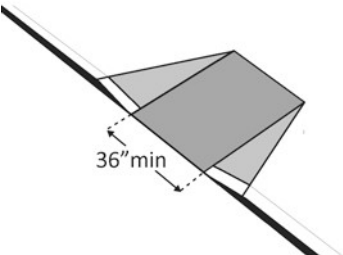
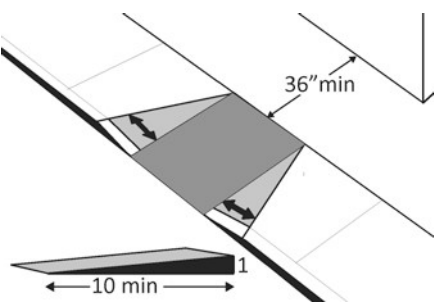
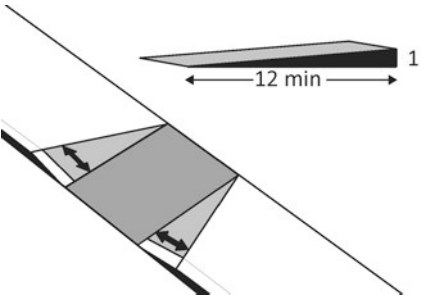
<p>5.18 Is the curb ramp, excluding flares, at least 36 inches wide? [406.1, 405.5]</p>	<p><input checked="" type="checkbox"/> Yes <input type="checkbox"/> No</p> <p>Measurement: 36"</p>		
<p>5.19 At the top of the curb ramp is there a level landing (slope no steeper than 1:48 in all directions) that is at least 36 inches long and at least as wide as the curb ramp? [406.4]</p> <p>If there are curb ramp flares, are the slopes of the flares no steeper than 1:10, i.e. for every inch of height change there are at least 10 inches of flare run? [406.3]</p>	<p><input type="checkbox"/> Yes <input checked="" type="checkbox"/> No</p> <p>Measurement: 2.8%</p> <p><input type="checkbox"/> Yes <input checked="" type="checkbox"/> No</p> <p>Measurement:</p>		
<p>5.20 If the landing at the top is less than 36 inches long, are there curb ramp flares? [406.4]</p> <p>Are the slopes of the flares no greater than 1:12, i.e. for every inch of height change there are at least 12 inches of flare run? [406.4]</p>	<p><input type="checkbox"/> Yes <input checked="" type="checkbox"/> No</p> <p><input type="checkbox"/> Yes <input checked="" type="checkbox"/> No</p> <p>Measurement:</p>		
<p>Accessible Play Components <input type="checkbox"/> Yes <input checked="" type="checkbox"/> No</p>			
<p>5.21 <u>Ground Level Play Components</u> Is there an accessible route to at least one of each type of ground level play component? Notes: 1. A play component is an element designed to generate play, socialization and learning. 2. Ground level play components are components that can be approached and exited at</p>	<p><input type="checkbox"/> Yes <input checked="" type="checkbox"/> No</p>		<p>Accessible equipment but playground has curb surrounding it without ramps</p>

ADA Checklist for Existing Facilities - Parks

<p>ground level. Examples include rockers, swings, diggers and stand-alone slides.</p>			
<p>5.22 <u>Elevated Play Components</u> Are there any accessible elevated play components? If so, is there an accessible route to the components?</p>	<p><input type="checkbox"/> Yes <input checked="" type="checkbox"/> No <input type="checkbox"/> Yes <input checked="" type="checkbox"/> No</p>		
<p>5.23 Is the vertical clearance of the accessible route at least 80 inches above the ground surface? Note: Objects below 80 inches may not protrude into the accessible route.</p>	<p><input checked="" type="checkbox"/> Yes <input type="checkbox"/> No</p>		
<p>Pavilion <input type="checkbox"/> Yes <input checked="" type="checkbox"/> No</p>			
<p>5.24 Is there an accessible route that is stable, firm and slip-resistant? [302.1]</p>	<p><input type="checkbox"/> Yes <input type="checkbox"/> No</p>		
<p>5.25 Is the route at least 36 inches wide? [403.5.1]</p>	<p><input type="checkbox"/> Yes <input type="checkbox"/> No</p>		
<p>5.26 Is the running slope no steeper than 1:20, i.e. for every inch of height change there are at least 20 inches of route run? [403.3] Note: If the running slope is steeper than 1:20, treat as a ramp and add features such as edge protection and handrails.</p>	<p><input type="checkbox"/> Yes <input type="checkbox"/> No Measurement:</p>		

ADA Checklist for Existing Facilities - Parks

<p>5.27 Is the cross slope no steeper than 1:48? [403.3]</p>	<p><input type="checkbox"/> Yes <input type="checkbox"/> No</p> <p>Measurement:</p>	
---	---	--

Benches Yes No

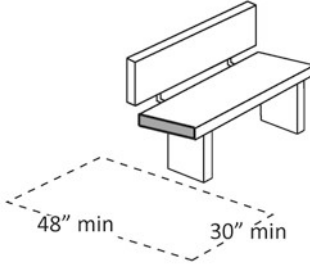
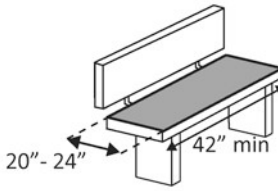
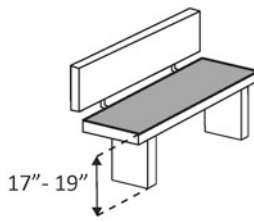
<p>5.28 Is there a clear floor space at least 30 inches wide by at least 48 inches long at the end of the bench and parallel to the short axis of the bench?</p> <p>Is the bench seat at least 42 inches long and no less than 20 inches and no greater than 24 inches deep?</p> <p>Does the bench have back support or is it affixed to a wall?</p> <p>Is the top of the bench seat no less than 17 inches and no greater than 19 inches above the floor? [903]</p>	<p><input checked="" type="checkbox"/> Yes <input type="checkbox"/> No</p> <p>Measurement:</p> <p><input checked="" type="checkbox"/> Yes <input type="checkbox"/> No</p> <p>Measurement:</p> <p>70"</p> <p><input checked="" type="checkbox"/> Yes <input type="checkbox"/> No</p> <p><input checked="" type="checkbox"/> Yes <input type="checkbox"/> No</p> <p>Measurement:</p> <p>17"</p>	<p>Ground</p>   	
---	---	---	--

Dining Tables Yes No

<p>5.28 Are at least 5 percent, but not less than one, of the dining surfaces for the seating and standing spaces accessible?</p> <p>Is/are the accessible space(s) distributed throughout the facility and located on an accessible route?</p>	<p><input checked="" type="checkbox"/> Yes <input type="checkbox"/> No</p> <p>Total #: 2 Accessible #: 2</p> <p><input checked="" type="checkbox"/> Yes <input type="checkbox"/> No</p>	
--	---	--

ADA Checklist for Existing Facilities - Parks

City of Grand Rapids ADA Transition Plan

Building: Hale Lake Landing

Location: _____

Date: 10/8/19

Evaluated By: Dom DeGuseppi

Priority 5 - Parks



5.1	Is there at least one route from site arrival points (parking, passenger loading zones, public sidewalks and public transportation stops) that does not require the use of stairs? [See 2010 ADA Standards for Accessible Design – 206.2.1]	<input type="checkbox"/> Yes <input checked="" type="checkbox"/> No If yes, location of route:		
------------	--	---	--	--

Parking Yes No

5.2	If parking is provided for the public, are an adequate number of accessible spaces provided? [208.2]	<input type="checkbox"/> Yes <input checked="" type="checkbox"/> No Total #: Accessible #:	Total Spaces	Accessible Spaces	No marked spaces
			1 - 25	1	
			26 - 50	2	
			51 - 75	3	
			76 - 100	4	
			100+ see 2010 Standards 208.2		

5.3	Are accessible spaces at least 8 feet wide with an access aisle at least 8 feet wide? [502.2, 502.3] Note: Two spaces may share an access aisle. Check state/local requirements;	<input type="checkbox"/> Yes <input checked="" type="checkbox"/> No Measurement:		
------------	--	---	--	--

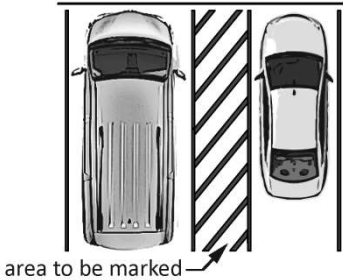
ADA Checklist for Existing Facilities - Parks

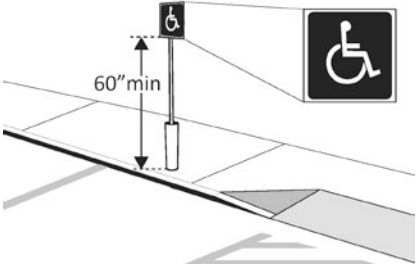
	some specify that each space have its own aisle.		
<p>5.4 Are the access aisles marked with signage and surface painting so as to discourage parking in them? [502.3.3]</p> <p>Note: The marking method and color may be addressed by state/local requirements.</p>	<p><input type="checkbox"/> Yes <input checked="" type="checkbox"/> No</p>		
<p>5.5 Is the slope of the accessible parking spaces and access aisles no steeper than 1:48 in all directions? [502.4]</p>	<p><input type="checkbox"/> Yes <input checked="" type="checkbox"/> No</p> <p>Measurement:</p>		
<p>5.6 Do the access aisles adjoin an accessible route? [502.3]</p>	<p><input type="checkbox"/> Yes <input checked="" type="checkbox"/> No</p>		
<p>5.7 Are accessible spaces identified with a sign that includes the International Symbol of Accessibility?</p> <p>Is the bottom of the sign at least 60 inches and not greater than 66 inches above the ground? [502.6]</p>	<p><input type="checkbox"/> Yes <input checked="" type="checkbox"/> No</p> <p><input type="checkbox"/> Yes <input checked="" type="checkbox"/> No</p> <p>Measurement:</p>		
<p>5.8 Of the total parking spaces, are the accessible spaces located on the closest accessible route to the accessible entrance(s)? [208.3.1]</p>	<p><input type="checkbox"/> Yes <input checked="" type="checkbox"/> No</p>		

Exterior Accessible Route

5.9 Is the route stable, firm and slip-resistant?
[302.1] Yes No

5.10 Is the route at least 36 inches wide?
[403.5.1] Yes No

Measurement:

Note: The accessible route can narrow to 32 inches min. for a max. of 24 inches. These narrower portions of the route must be at least 48 inches from each other.

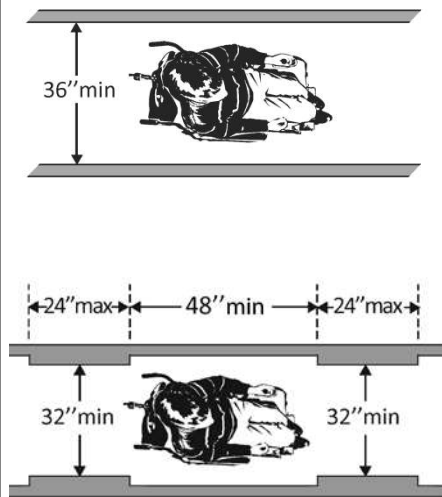

5.11 If the route is greater than 200 feet in length and less than 60 inches wide, is there a passing space no less than 60 x 60 inches?
[403.5.3] Yes No

Measurement:

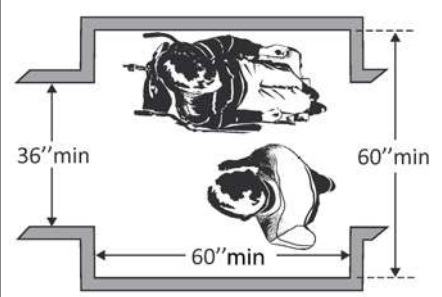

5.12 If there are grates or openings on the route, are the openings no larger than 1/2 inches?
[403.5.3]

If the route is greater than 200 feet in length and less than 60 inches wide, is there a passing space no less than 60 x 60 inches?
[403.5.3]

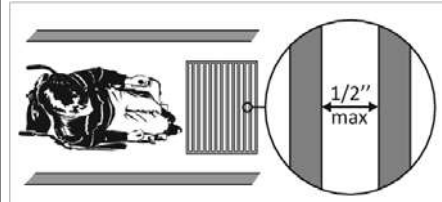

ADA Checklist for Existing Facilities - Parks

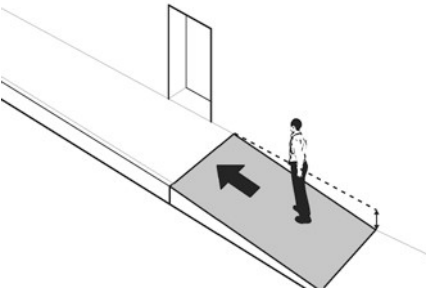
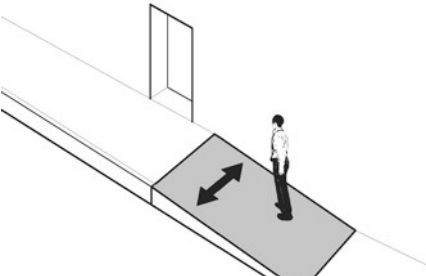
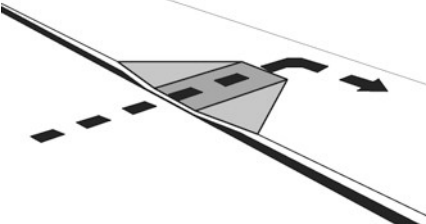
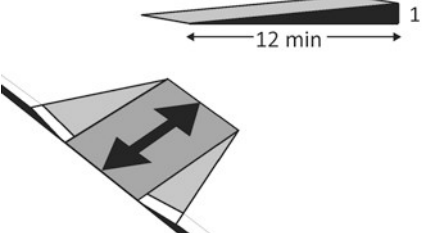
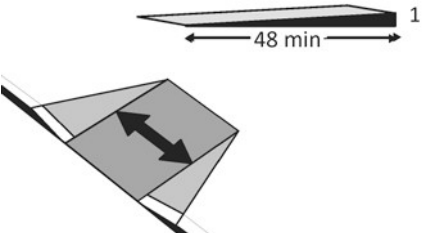
<p>5.13 Is the running slope no steeper than 1:20, i.e. for every inch of height change there are at least 20 inches of route run? [403.3]</p> <p>Note: If the running slope is steeper than 1:20, treat as a ramp and add features such as edge protection and handrails.</p>	<p><input type="checkbox"/> Yes <input checked="" type="checkbox"/> No</p> <p>Measurement:</p>		
<p>5.14 Is the cross slope no steeper than 1:48? [403.3]</p>	<p><input type="checkbox"/> Yes <input checked="" type="checkbox"/> No</p> <p>Measurement:</p>		
<p>Curb Ramps <input type="checkbox"/> Yes <input checked="" type="checkbox"/> No</p>			
<p>5.15 If the accessible route crosses a curb, is there a curb ramp? [402.2]</p>	<p><input type="checkbox"/> Yes <input type="checkbox"/> No</p>		
<p>5.16 Is the running slope of the curb ramp no steeper than 1:12, i.e. for every inch of height change there are at least 12 inches of curb ramp run? [406.1, 405.2]</p>	<p><input type="checkbox"/> Yes <input type="checkbox"/> No</p> <p>Measurement:</p>		
<p>5.17 Is the cross slope of the curb ramp, excluding flares, no steeper than 1:48? [406.1, 405.3]</p>	<p><input type="checkbox"/> Yes <input type="checkbox"/> No</p> <p>Measurement:</p>		

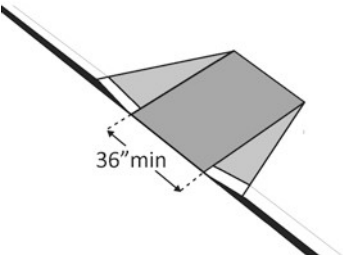
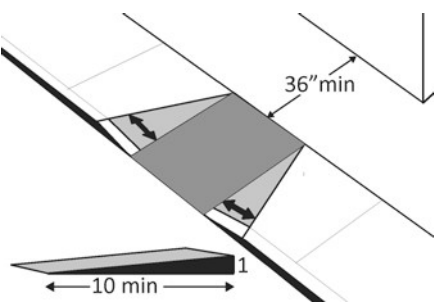
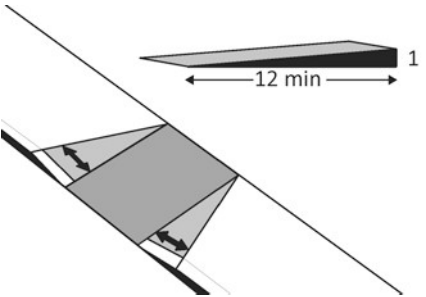
<p>5.18 Is the curb ramp, excluding flares, at least 36 inches wide? [406.1, 405.5]</p>	<p><input type="checkbox"/> Yes <input type="checkbox"/> No</p> <p>Measurement:</p>		
<p>5.19 At the top of the curb ramp is there a level landing (slope no steeper than 1:48 in all directions) that is at least 36 inches long and at least as wide as the curb ramp? [406.4]</p> <p>If there are curb ramp flares, are the slopes of the flares no steeper than 1:10, i.e. for every inch of height change there are at least 10 inches of flare run? [406.3]</p>	<p><input type="checkbox"/> Yes <input type="checkbox"/> No</p> <p>Measurement:</p> <p><input type="checkbox"/> Yes <input type="checkbox"/> No</p> <p>Measurement:</p>		
<p>5.20 If the landing at the top is less than 36 inches long, are there curb ramp flares? [406.4]</p> <p>Are the slopes of the flares no greater than 1:12, i.e. for every inch of height change there are at least 12 inches of flare run? [406.4]</p>	<p><input type="checkbox"/> Yes <input type="checkbox"/> No</p> <p><input type="checkbox"/> Yes <input type="checkbox"/> No</p> <p>Measurement:</p>		
<p>Accessible Play Components <input type="checkbox"/> Yes <input checked="" type="checkbox"/> No</p>			
<p>5.21 <u>Ground Level Play Components</u> Is there an accessible route to at least one of each type of ground level play component?</p> <p>Notes:</p> <ol style="list-style-type: none"> 1. A play component is an element designed to generate play, socialization and learning. 2. Ground level play components are components that can be approached and exited at 	<p><input type="checkbox"/> Yes <input type="checkbox"/> No</p>		

ADA Checklist for Existing Facilities - Parks

<p>ground level. Examples include rockers, swings, diggers and stand-alone slides.</p>			
<p>5.22 <u>Elevated Play Components</u> Are there any accessible elevated play components? If so, is there an accessible route to the components?</p>	<p><input type="checkbox"/> Yes <input type="checkbox"/> No <input type="checkbox"/> Yes <input type="checkbox"/> No</p>		
<p>5.23 Is the vertical clearance of the accessible route at least 80 inches above the ground surface? Note: Objects below 80 inches may not protrude into the accessible route.</p>	<p><input type="checkbox"/> Yes <input type="checkbox"/> No</p>		
<p>Pavilion <input type="checkbox"/> Yes <input checked="" type="checkbox"/> No</p>			
<p>5.24 Is there an accessible route that is stable, firm and slip-resistant? [302.1]</p>	<p><input type="checkbox"/> Yes <input type="checkbox"/> No</p>		
<p>5.25 Is the route at least 36 inches wide? [403.5.1]</p>	<p><input type="checkbox"/> Yes <input type="checkbox"/> No</p>		
<p>5.26 Is the running slope no steeper than 1:20, i.e. for every inch of height change there are at least 20 inches of route run? [403.3] Note: If the running slope is steeper than 1:20, treat as a ramp and add features such as edge protection and handrails.</p>	<p><input type="checkbox"/> Yes <input type="checkbox"/> No Measurement:</p>		

ADA Checklist for Existing Facilities - Parks

<p>5.27 Is the cross slope no steeper than 1:48? [403.3]</p>	<p><input type="checkbox"/> Yes <input type="checkbox"/> No</p> <p>Measurement:</p>	
---	---	--

Benches Yes No

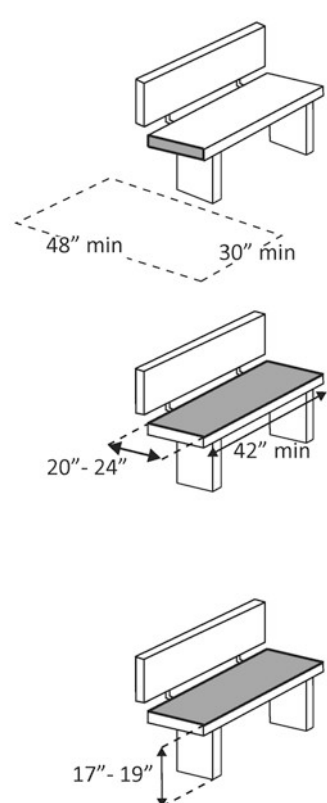
<p>5.28 Is there a clear floor space at least 30 inches wide by at least 48 inches long at the end of the bench and parallel to the short axis of the bench?</p> <p>Is the bench seat at least 42 inches long and no less than 20 inches and no greater than 24 inches deep?</p> <p>Does the bench have back support or is it affixed to a wall?</p> <p>Is the top of the bench seat no less than 17 inches and no greater than 19 inches above the floor? [903]</p>	<p><input type="checkbox"/> Yes <input type="checkbox"/> No</p> <p>Measurement:</p> <p><input type="checkbox"/> Yes <input type="checkbox"/> No</p> <p>Measurement:</p> <p><input type="checkbox"/> Yes <input type="checkbox"/> No</p> <p><input type="checkbox"/> Yes <input type="checkbox"/> No</p> <p>Measurement:</p>	
---	---	---

Dining Tables Yes No

<p>5.28 Are at least 5 percent, but not less than one, of the dining surfaces for the seating and standing spaces accessible?</p> <p>Is/are the accessible space(s) distributed throughout the facility and located on an accessible route?</p>	<p><input checked="" type="checkbox"/> Yes <input type="checkbox"/> No</p> <p>Total #: 2 Accessible #: 1</p> <p><input checked="" type="checkbox"/> Yes <input type="checkbox"/> No</p>	
--	---	--

ADA Checklist for Existing Facilities - Parks

City of Grand Rapids ADA Transition Plan

Building: Hillside Park

Location: Forest Hills Avenue

Date: 10/1/19

Evaluated By: Dom DeGuseppi

Priority 5 - Parks

5.1 Is there at least one route from site arrival points (parking, passenger loading zones, public sidewalks and public transportation stops) that does not require the use of stairs? [See 2010 ADA Standards for Accessible Design – 206.2.1]

Yes No

If yes, location of route:

Parking Yes No

5.2 If parking is provided for the public, are an adequate number of accessible spaces provided? [208.2]

Yes No

Total #:
Accessible #:

Total Spaces	Accessible Spaces
1 - 25	1
26 - 50	2
51 - 75	3
76 - 100	4
100+ see 2010 Standards 208.2	



5.3 Are accessible spaces at least 8 feet wide with an access aisle at least 8 feet wide? [502.2, 502.3]

Yes No

Measurement:

Note: Two spaces may share an access aisle. Check state/local requirements;

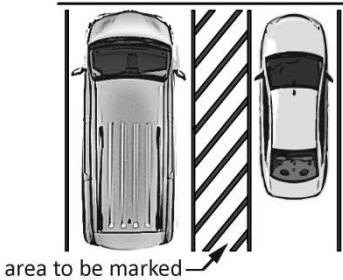
ADA Checklist for Existing Facilities - Parks

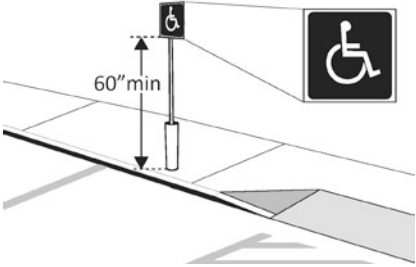
	some specify that each space have its own aisle.			
5.4	<p>Are the access aisles marked with signage and surface painting so as to discourage parking in them? [502.3.3]</p> <p>Note: The marking method and color may be addressed by state/local requirements.</p>	<input type="checkbox"/> Yes <input checked="" type="checkbox"/> No		
5.5	<p>Is the slope of the accessible parking spaces and access aisles no steeper than 1:48 in all directions? [502.4]</p>	<input type="checkbox"/> Yes <input checked="" type="checkbox"/> No Measurement:		
5.6	<p>Do the access aisles adjoin an accessible route? [502.3]</p>	<input type="checkbox"/> Yes <input checked="" type="checkbox"/> No		
5.7	<p>Are accessible spaces identified with a sign that includes the International Symbol of Accessibility? Is the bottom of the sign at least 60 inches and not greater than 66 inches above the ground? [502.6]</p>	<input type="checkbox"/> Yes <input checked="" type="checkbox"/> No <input type="checkbox"/> Yes <input checked="" type="checkbox"/> No Measurement:		
5.8	<p>Of the total parking spaces, are the accessible spaces located on the closest accessible route to the accessible entrance(s)? [208.3.1]</p>	<input type="checkbox"/> Yes <input checked="" type="checkbox"/> No		

Exterior Accessible Route

5.9 Is the route stable, firm and slip-resistant?
[302.1] Yes No

5.10 Is the route at least 36 inches wide?
[403.5.1] Yes No

Measurement:

Note: The accessible route can narrow to 32 inches min. for a max. of 24 inches. These narrower portions of the route must be at least 48 inches from each other.

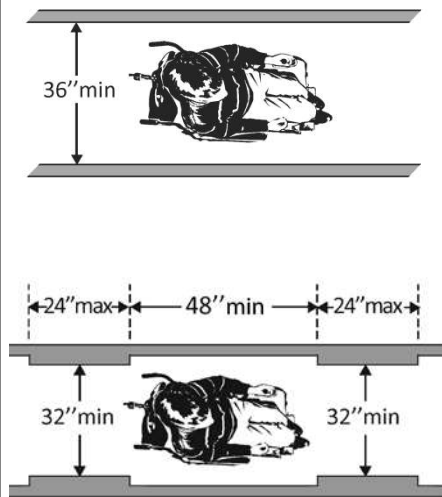

5.11 If the route is greater than 200 feet in length and less than 60 inches wide, is there a passing space no less than 60 x 60 inches?
[403.5.3] Yes No

Measurement:

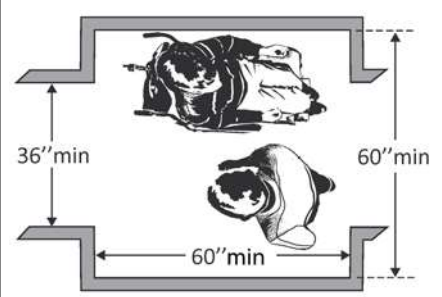

5.12 If there are grates or openings on the route, are the openings no larger than 1/2 inches?
[403.5.3]

If the route is greater than 200 feet in length and less than 60 inches wide, is there a passing space no less than 60 x 60 inches?
[403.5.3]

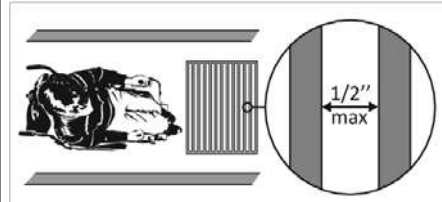

ADA Checklist for Existing Facilities - Parks

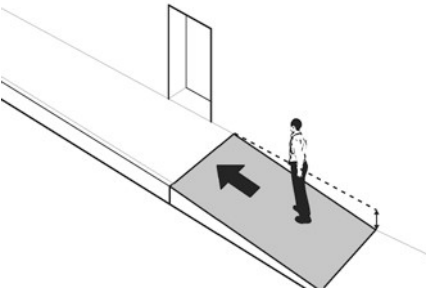
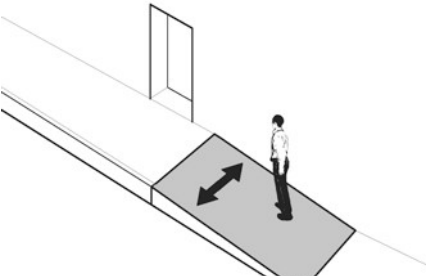
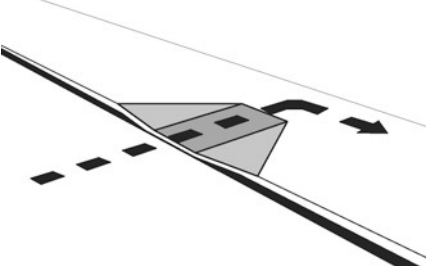
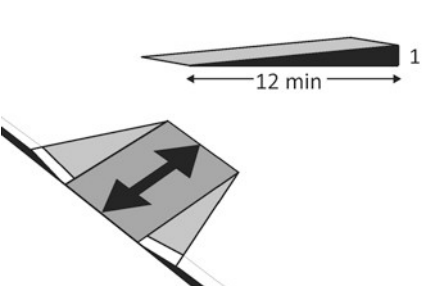
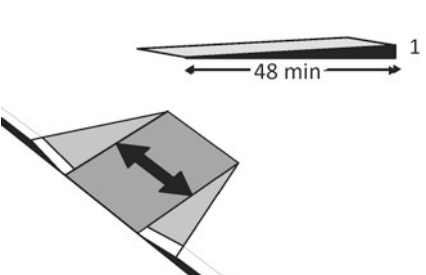
<p>5.13 Is the running slope no steeper than 1:20, i.e. for every inch of height change there are at least 20 inches of route run? [403.3]</p> <p>Note: If the running slope is steeper than 1:20, treat as a ramp and add features such as edge protection and handrails.</p>	<p><input type="checkbox"/> Yes <input checked="" type="checkbox"/> No</p> <p>Measurement:</p>		
<p>5.14 Is the cross slope no steeper than 1:48? [403.3]</p>	<p><input type="checkbox"/> Yes <input checked="" type="checkbox"/> No</p> <p>Measurement:</p>		
<p>Curb Ramps <input type="checkbox"/> Yes <input checked="" type="checkbox"/> No</p>			
<p>5.15 If the accessible route crosses a curb, is there a curb ramp? [402.2]</p>	<p><input type="checkbox"/> Yes <input type="checkbox"/> No</p>		
<p>5.16 Is the running slope of the curb ramp no steeper than 1:12, i.e. for every inch of height change there are at least 12 inches of curb ramp run? [406.1, 405.2]</p>	<p><input type="checkbox"/> Yes <input type="checkbox"/> No</p> <p>Measurement:</p>		
<p>5.17 Is the cross slope of the curb ramp, excluding flares, no steeper than 1:48? [406.1, 405.3]</p>	<p><input type="checkbox"/> Yes <input type="checkbox"/> No</p> <p>Measurement:</p>		

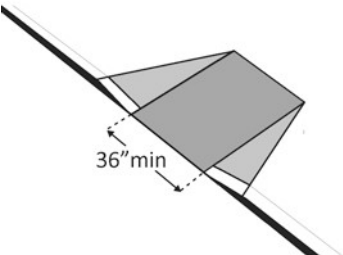
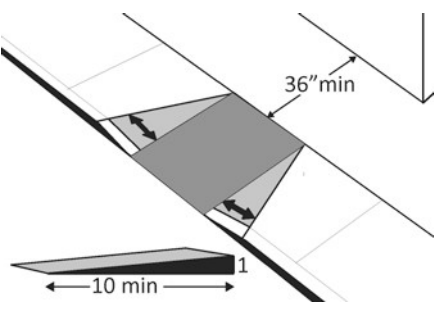
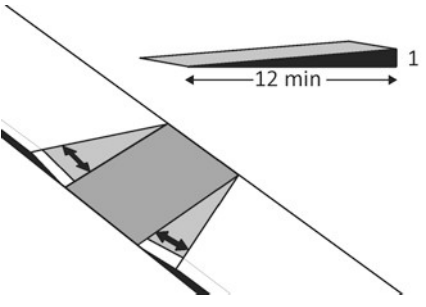
<p>5.18 Is the curb ramp, excluding flares, at least 36 inches wide? [406.1, 405.5]</p>	<p><input type="checkbox"/> Yes <input type="checkbox"/> No</p> <p>Measurement:</p>		
<p>5.19 At the top of the curb ramp is there a level landing (slope no steeper than 1:48 in all directions) that is at least 36 inches long and at least as wide as the curb ramp? [406.4]</p> <p>If there are curb ramp flares, are the slopes of the flares no steeper than 1:10, i.e. for every inch of height change there are at least 10 inches of flare run? [406.3]</p>	<p><input type="checkbox"/> Yes <input type="checkbox"/> No</p> <p>Measurement:</p> <p><input type="checkbox"/> Yes <input type="checkbox"/> No</p> <p>Measurement:</p>		
<p>5.20 If the landing at the top is less than 36 inches long, are there curb ramp flares? [406.4]</p> <p>Are the slopes of the flares no greater than 1:12, i.e. for every inch of height change there are at least 12 inches of flare run? [406.4]</p>	<p><input type="checkbox"/> Yes <input type="checkbox"/> No</p> <p><input type="checkbox"/> Yes <input type="checkbox"/> No</p> <p>Measurement:</p>		
<p>Accessible Play Components <input type="checkbox"/> Yes <input checked="" type="checkbox"/> No</p>			
<p>5.21 <u>Ground Level Play Components</u> Is there an accessible route to at least one of each type of ground level play component?</p> <p>Notes:</p> <ol style="list-style-type: none"> 1. A play component is an element designed to generate play, socialization and learning. 2. Ground level play components are components that can be approached and exited at 	<p><input type="checkbox"/> Yes <input type="checkbox"/> No</p>		

ADA Checklist for Existing Facilities - Parks

<p>ground level. Examples include rockers, swings, diggers and stand-alone slides.</p>			
<p>5.22 <u>Elevated Play Components</u> Are there any accessible elevated play components? If so, is there an accessible route to the components?</p>	<p><input type="checkbox"/> Yes <input type="checkbox"/> No <input type="checkbox"/> Yes <input type="checkbox"/> No</p>		
<p>5.23 Is the vertical clearance of the accessible route at least 80 inches above the ground surface? Note: Objects below 80 inches may not protrude into the accessible route.</p>	<p><input type="checkbox"/> Yes <input type="checkbox"/> No</p>		
<p>Pavilion <input type="checkbox"/> Yes <input checked="" type="checkbox"/> No</p>			
<p>5.24 Is there an accessible route that is stable, firm and slip-resistant? [302.1]</p>	<p><input type="checkbox"/> Yes <input type="checkbox"/> No</p>		
<p>5.25 Is the route at least 36 inches wide? [403.5.1]</p>	<p><input type="checkbox"/> Yes <input type="checkbox"/> No</p>		
<p>5.26 Is the running slope no steeper than 1:20, i.e. for every inch of height change there are at least 20 inches of route run? [403.3] Note: If the running slope is steeper than 1:20, treat as a ramp and add features such as edge protection and handrails.</p>	<p><input type="checkbox"/> Yes <input type="checkbox"/> No Measurement:</p>		

ADA Checklist for Existing Facilities - Parks

<p>5.27 Is the cross slope no steeper than 1:48? [403.3]</p>	<p><input type="checkbox"/> Yes <input type="checkbox"/> No</p> <p>Measurement:</p>	
---	---	--

Benches Yes No

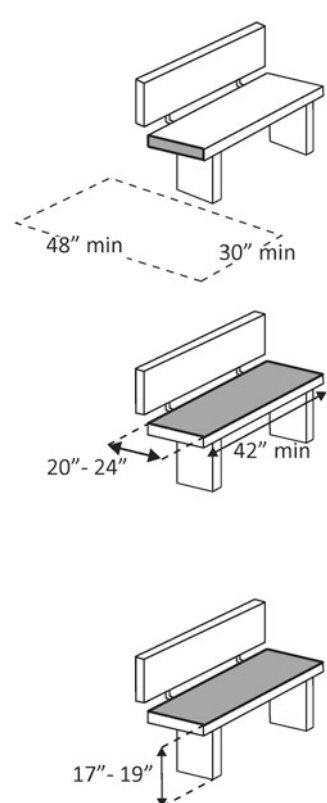
<p>5.28 Is there a clear floor space at least 30 inches wide by at least 48 inches long at the end of the bench and parallel to the short axis of the bench?</p> <p>Is the bench seat at least 42 inches long and no less than 20 inches and no greater than 24 inches deep?</p> <p>Does the bench have back support or is it affixed to a wall?</p> <p>Is the top of the bench seat no less than 17 inches and no greater than 19 inches above the floor? [903]</p>	<p><input type="checkbox"/> Yes <input type="checkbox"/> No</p> <p>Measurement:</p> <p><input type="checkbox"/> Yes <input type="checkbox"/> No</p> <p>Measurement:</p> <p><input type="checkbox"/> Yes <input type="checkbox"/> No</p> <p><input type="checkbox"/> Yes <input type="checkbox"/> No</p> <p>Measurement:</p>	
---	---	---

Dining Tables Yes No

<p>5.28 Are at least 5 percent, but not less than one, of the dining surfaces for the seating and standing spaces accessible?</p> <p>Is/are the accessible space(s) distributed throughout the facility and located on an accessible route?</p>	<p><input type="checkbox"/> Yes <input type="checkbox"/> No</p> <p>Total #: Accessible #:</p> <p><input type="checkbox"/> Yes <input type="checkbox"/> No</p>	
--	---	--

ADA Checklist for Existing Facilities - Parks

City of Grand Rapids ADA Transition Plan

Building: Isaac Walton Landing

Location: County Road 63

Date: 10/2/19

Evaluated By: Dom DeGuseppi

Priority 5 - Parks

5.1 Is there at least one route from site arrival points (parking, passenger loading zones, public sidewalks and public transportation stops) that does not require the use of stairs?
[See 2010 ADA Standards for Accessible Design – 206.2.1]

Yes No

If yes, location of route:

Parking Yes No

5.2 If parking is provided for the public, are an adequate number of accessible spaces provided? [208.2]	<input type="checkbox"/> Yes <input checked="" type="checkbox"/> No Total #: Accessible #:	Total Spaces	Accessible Spaces	Dirt lot
		1 - 25	1	
		26 - 50	2	
		51 - 75	3	
		76 - 100	4	
		100+ see 2010 Standards 208.2		



5.3 Are accessible spaces at least 8 feet wide with an access aisle at least 8 feet wide?
[502.2, 502.3]

Yes No

Measurement:

Note: Two spaces may share an access aisle. Check state/local requirements;

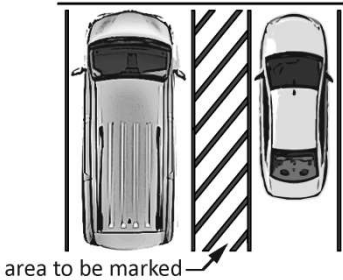
ADA Checklist for Existing Facilities - Parks

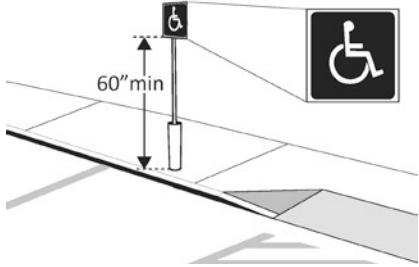
	some specify that each space have its own aisle.			
5.4	<p>Are the access aisles marked with signage and surface painting so as to discourage parking in them? [502.3.3]</p> <p>Note: The marking method and color may be addressed by state/local requirements.</p>	<input type="checkbox"/> Yes <input checked="" type="checkbox"/> No		
5.5	<p>Is the slope of the accessible parking spaces and access aisles no steeper than 1:48 in all directions? [502.4]</p>	<input type="checkbox"/> Yes <input checked="" type="checkbox"/> No Measurement: NA		
5.6	<p>Do the access aisles adjoin an accessible route? [502.3]</p>	<input type="checkbox"/> Yes <input checked="" type="checkbox"/> No		
5.7	<p>Are accessible spaces identified with a sign that includes the International Symbol of Accessibility?</p> <p>Is the bottom of the sign at least 60 inches and not greater than 66 inches above the ground? [502.6]</p>	<input type="checkbox"/> Yes <input checked="" type="checkbox"/> No <input type="checkbox"/> Yes <input checked="" type="checkbox"/> No Measurement:		
5.8	<p>Of the total parking spaces, are the accessible spaces located on the closest accessible route to the accessible entrance(s)? [208.3.1]</p>	<input type="checkbox"/> Yes <input checked="" type="checkbox"/> No		

Exterior Accessible Route

5.9 Is the route stable, firm and slip-resistant?
[302.1] Yes No

5.10 Is the route at least 36 inches wide?
[403.5.1] Yes No

Measurement:

Note: The accessible route can narrow to 32 inches min. for a max. of 24 inches. These narrower portions of the route must be at least 48 inches from each other.

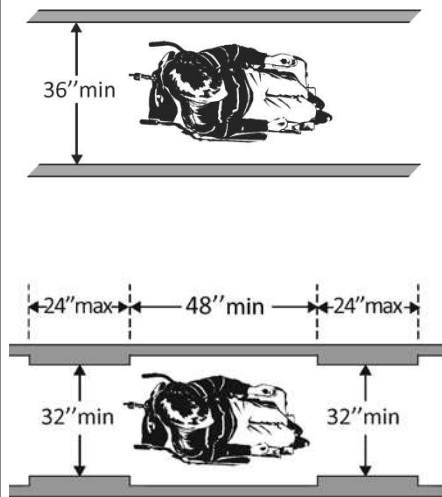

5.11 If the route is greater than 200 feet in length and less than 60 inches wide, is there a passing space no less than 60 x 60 inches?
[403.5.3] Yes No

Measurement:

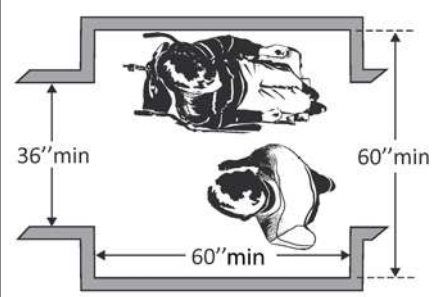

5.12 If there are grates or openings on the route, are the openings no larger than 1/2 inches?
[403.5.3]

If the route is greater than 200 feet in length and less than 60 inches wide, is there a passing space no less than 60 x 60 inches?
[403.5.3]

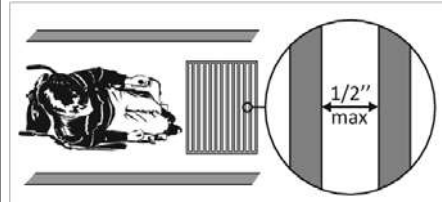

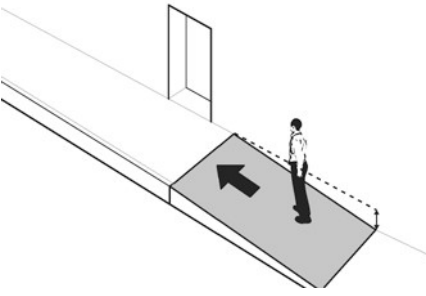
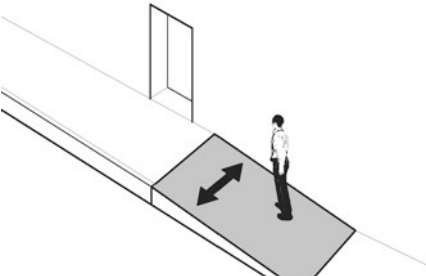
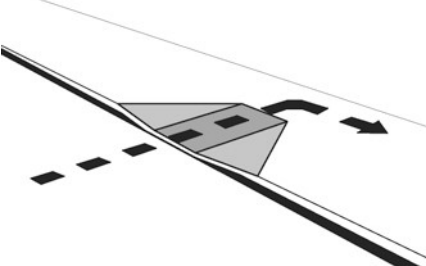
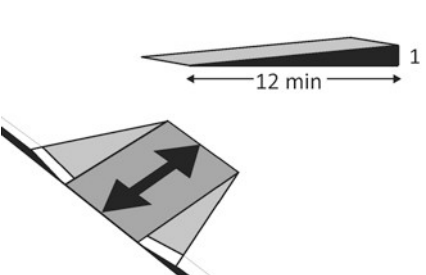
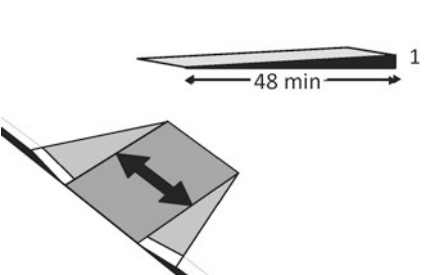
<p>5.13 Is the running slope no steeper than 1:20, i.e. for every inch of height change there are at least 20 inches of route run? [403.3]</p> <p>Note: If the running slope is steeper than 1:20, treat as a ramp and add features such as edge protection and handrails.</p>	<p><input type="checkbox"/> Yes <input checked="" type="checkbox"/> No</p> <p>Measurement:</p>		
<p>5.14 Is the cross slope no steeper than 1:48? [403.3]</p>	<p><input type="checkbox"/> Yes <input checked="" type="checkbox"/> No</p> <p>Measurement:</p>		
<p>Curb Ramps <input type="checkbox"/> Yes <input checked="" type="checkbox"/> No</p>			
<p>5.15 If the accessible route crosses a curb, is there a curb ramp? [402.2]</p>	<p><input type="checkbox"/> Yes <input type="checkbox"/> No</p>		
<p>5.16 Is the running slope of the curb ramp no steeper than 1:12, i.e. for every inch of height change there are at least 12 inches of curb ramp run? [406.1, 405.2]</p>	<p><input type="checkbox"/> Yes <input type="checkbox"/> No</p> <p>Measurement:</p>		
<p>5.17 Is the cross slope of the curb ramp, excluding flares, no steeper than 1:48? [406.1, 405.3]</p>	<p><input type="checkbox"/> Yes <input type="checkbox"/> No</p> <p>Measurement:</p>		

ADA Checklist for Existing Facilities - Parks

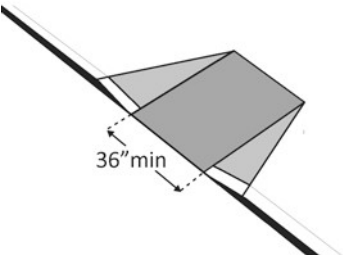
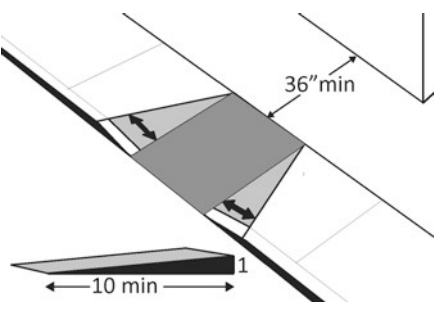
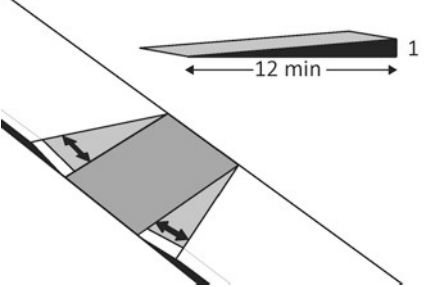
<p>5.18 Is the curb ramp, excluding flares, at least 36 inches wide? [406.1, 405.5]</p>	<p><input type="checkbox"/> Yes <input type="checkbox"/> No</p> <p>Measurement:</p>		
<p>5.19 At the top of the curb ramp is there a level landing (slope no steeper than 1:48 in all directions) that is at least 36 inches long and at least as wide as the curb ramp? [406.4]</p> <p>If there are curb ramp flares, are the slopes of the flares no steeper than 1:10, i.e. for every inch of height change there are at least 10 inches of flare run? [406.3]</p>	<p><input type="checkbox"/> Yes <input type="checkbox"/> No</p> <p>Measurement:</p> <p><input type="checkbox"/> Yes <input type="checkbox"/> No</p> <p>Measurement:</p>		
<p>5.20 If the landing at the top is less than 36 inches long, are there curb ramp flares? [406.4]</p> <p>Are the slopes of the flares no greater than 1:12, i.e. for every inch of height change there are at least 12 inches of flare run? [406.4]</p>	<p><input type="checkbox"/> Yes <input type="checkbox"/> No</p> <p><input type="checkbox"/> Yes <input type="checkbox"/> No</p> <p>Measurement:</p>		
<p>Accessible Play Components <input type="checkbox"/> Yes <input checked="" type="checkbox"/> No</p>			
<p>5.21 <u>Ground Level Play Components</u> Is there an accessible route to at least one of each type of ground level play component?</p> <p>Notes:</p> <ol style="list-style-type: none"> 1. A play component is an element designed to generate play, socialization and learning. 2. Ground level play components are components that can be approached and exited at 	<p><input type="checkbox"/> Yes <input type="checkbox"/> No</p>		

ADA Checklist for Existing Facilities - Parks

<p>ground level. Examples include rockers, swings, diggers and stand-alone slides.</p>			
<p>5.22 <u>Elevated Play Components</u> Are there any accessible elevated play components? If so, is there an accessible route to the components?</p>	<p><input type="checkbox"/> Yes <input type="checkbox"/> No <input type="checkbox"/> Yes <input type="checkbox"/> No</p>		
<p>5.23 Is the vertical clearance of the accessible route at least 80 inches above the ground surface? Note: Objects below 80 inches may not protrude into the accessible route.</p>	<p><input type="checkbox"/> Yes <input type="checkbox"/> No</p>		
<p>Pavilion <input type="checkbox"/> Yes <input checked="" type="checkbox"/> No</p>			
<p>5.24 Is there an accessible route that is stable, firm and slip-resistant? [302.1]</p>	<p><input type="checkbox"/> Yes <input type="checkbox"/> No</p>		
<p>5.25 Is the route at least 36 inches wide? [403.5.1]</p>	<p><input type="checkbox"/> Yes <input type="checkbox"/> No</p>		
<p>5.26 Is the running slope no steeper than 1:20, i.e. for every inch of height change there are at least 20 inches of route run? [403.3] Note: If the running slope is steeper than 1:20, treat as a ramp and add features such as edge protection and handrails.</p>	<p><input type="checkbox"/> Yes <input type="checkbox"/> No Measurement:</p>		

ADA Checklist for Existing Facilities - Parks

<p>5.27 Is the cross slope no steeper than 1:48? [403.3]</p>	<p><input type="checkbox"/> Yes <input type="checkbox"/> No</p> <p>Measurement:</p>	
---	---	--

Benches Yes No

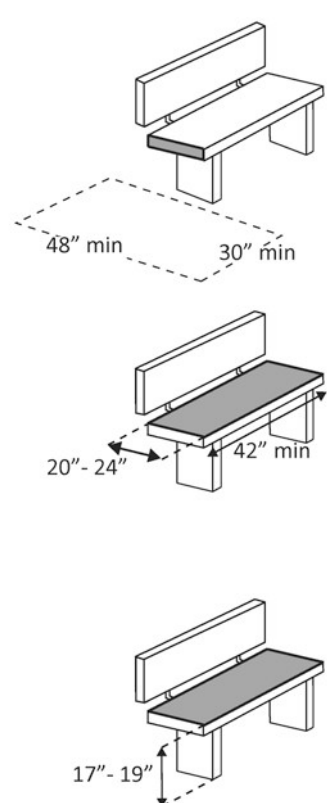
<p>5.28 Is there a clear floor space at least 30 inches wide by at least 48 inches long at the end of the bench and parallel to the short axis of the bench?</p> <p>Is the bench seat at least 42 inches long and no less than 20 inches and no greater than 24 inches deep?</p> <p>Does the bench have back support or is it affixed to a wall?</p> <p>Is the top of the bench seat no less than 17 inches and no greater than 19 inches above the floor? [903]</p>	<p><input type="checkbox"/> Yes <input type="checkbox"/> No</p> <p>Measurement:</p> <p><input type="checkbox"/> Yes <input type="checkbox"/> No</p> <p>Measurement:</p> <p><input type="checkbox"/> Yes <input type="checkbox"/> No</p> <p><input type="checkbox"/> Yes <input type="checkbox"/> No</p> <p>Measurement:</p>	 <p>The diagrams illustrate the required clearances for a bench. The top diagram shows a 48-inch by 30-inch clear floor space at the end of the bench. The middle diagram shows a seat depth of 20-24 inches and a seat length of 42 inches. The bottom diagram shows a seat height of 17-19 inches from the floor.</p>
---	---	--

Dining Tables Yes No

<p>5.28 Are at least 5 percent, but not less than one, of the dining surfaces for the seating and standing spaces accessible?</p> <p>Is/are the accessible space(s) distributed throughout the facility and located on an accessible route?</p>	<p><input type="checkbox"/> Yes <input type="checkbox"/> No</p> <p>Total #: Accessible #:</p> <p><input type="checkbox"/> Yes <input type="checkbox"/> No</p>	
--	---	--

ADA Checklist for Existing Facilities - Parks

City of Grand Rapids ADA Transition Plan

Building: Lost Creek Park

Location: NW 4th Ave

Date: 10/8/19

Evaluated By: Dom DeGuseppi

Priority 5 - Parks

5.1 Is there at least one route from site arrival points (parking, passenger loading zones, public sidewalks and public transportation stops) that does not require the use of stairs?
[See 2010 ADA Standards for Accessible Design – 206.2.1]

Yes No

If yes, location of route:

Parking Yes No

5.2 If parking is provided for the public, are an adequate number of accessible spaces provided? [208.2]	<input type="checkbox"/> Yes <input checked="" type="checkbox"/> No Total #: Accessible #:	Total Spaces	Accessible Spaces	Street Parking
		1 - 25	1	
		26 - 50	2	
		51 - 75	3	
		76 - 100	4	
		100+ see 2010 Standards 208.2		



5.3 Are accessible spaces at least 8 feet wide with an access aisle at least 8 feet wide?
[502.2, 502.3]

Yes No

Measurement:

Note: Two spaces may share an access aisle. Check state/local requirements;

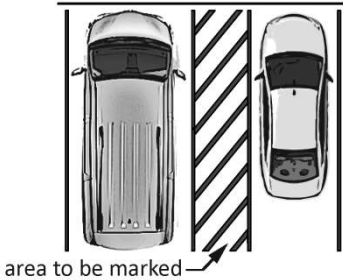
ADA Checklist for Existing Facilities - Parks

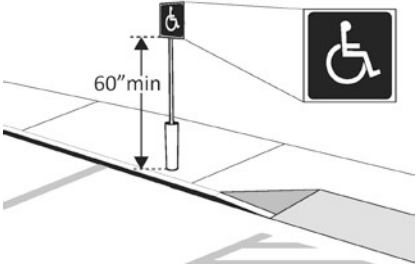
	some specify that each space have its own aisle.		
<p>5.4 Are the access aisles marked with signage and surface painting so as to discourage parking in them? [502.3.3]</p> <p>Note: The marking method and color may be addressed by state/local requirements.</p>	<p><input type="checkbox"/> Yes <input checked="" type="checkbox"/> No</p>		
<p>5.5 Is the slope of the accessible parking spaces and access aisles no steeper than 1:48 in all directions? [502.4]</p>	<p><input type="checkbox"/> Yes <input checked="" type="checkbox"/> No</p> <p>Measurement:</p>		
<p>5.6 Do the access aisles adjoin an accessible route? [502.3]</p>	<p><input type="checkbox"/> Yes <input checked="" type="checkbox"/> No</p>		
<p>5.7 Are accessible spaces identified with a sign that includes the International Symbol of Accessibility?</p> <p>Is the bottom of the sign at least 60 inches and not greater than 66 inches above the ground? [502.6]</p>	<p><input type="checkbox"/> Yes <input checked="" type="checkbox"/> No</p> <p><input type="checkbox"/> Yes <input checked="" type="checkbox"/> No</p> <p>Measurement:</p>		
<p>5.8 Of the total parking spaces, are the accessible spaces located on the closest accessible route to the accessible entrance(s)? [208.3.1]</p>	<p><input type="checkbox"/> Yes <input checked="" type="checkbox"/> No</p>		

Exterior Accessible Route

5.9 Is the route stable, firm and slip-resistant?
[302.1] Yes No

5.10 Is the route at least 36 inches wide?
[403.5.1] Yes No

Measurement:

Note: The accessible route can narrow to 32 inches min. for a max. of 24 inches. These narrower portions of the route must be at least 48 inches from each other.

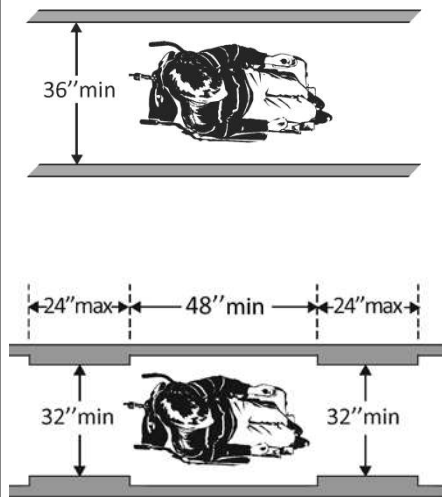

5.11 If the route is greater than 200 feet in length and less than 60 inches wide, is there a passing space no less than 60 x 60 inches?
[403.5.3] Yes No

Measurement:

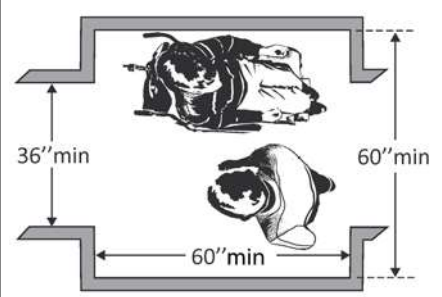

5.12 If there are grates or openings on the route, are the openings no larger than 1/2 inches?
[403.5.3]

If the route is greater than 200 feet in length and less than 60 inches wide, is there a passing space no less than 60 x 60 inches?
[403.5.3]

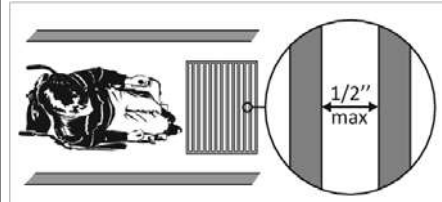

ADA Checklist for Existing Facilities - Parks

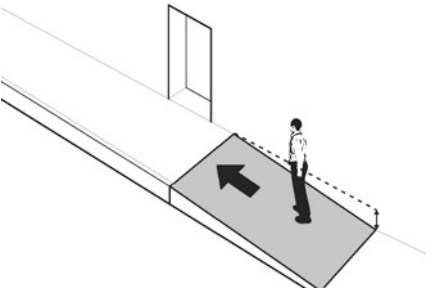
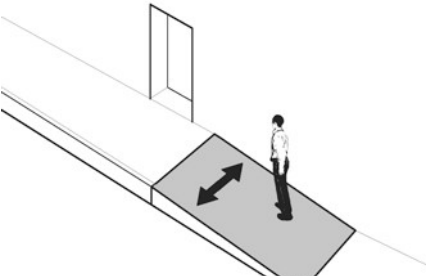
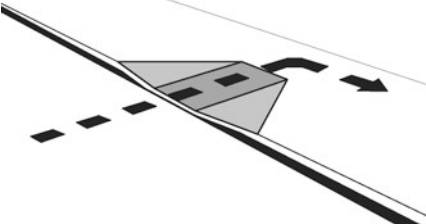
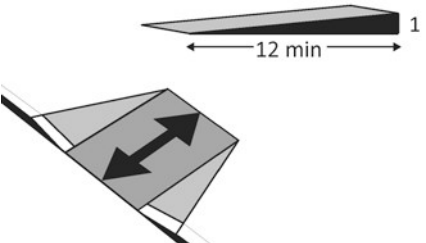
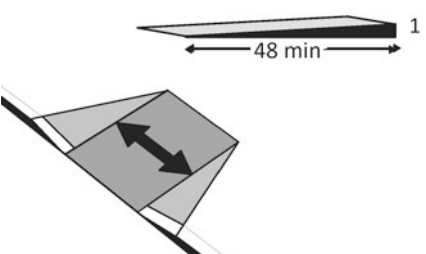
<p>5.13 Is the running slope no steeper than 1:20, i.e. for every inch of height change there are at least 20 inches of route run? [403.3]</p> <p>Note: If the running slope is steeper than 1:20, treat as a ramp and add features such as edge protection and handrails.</p>	<p><input type="checkbox"/> Yes <input checked="" type="checkbox"/> No</p> <p>Measurement:</p>		
<p>5.14 Is the cross slope no steeper than 1:48? [403.3]</p>	<p><input type="checkbox"/> Yes <input checked="" type="checkbox"/> No</p> <p>Measurement:</p>		
<p>Curb Ramps <input type="checkbox"/> Yes <input checked="" type="checkbox"/> No</p>			
<p>5.15 If the accessible route crosses a curb, is there a curb ramp? [402.2]</p>	<p><input type="checkbox"/> Yes <input type="checkbox"/> No</p>		
<p>5.16 Is the running slope of the curb ramp no steeper than 1:12, i.e. for every inch of height change there are at least 12 inches of curb ramp run? [406.1, 405.2]</p>	<p><input type="checkbox"/> Yes <input type="checkbox"/> No</p> <p>Measurement:</p>		
<p>5.17 Is the cross slope of the curb ramp, excluding flares, no steeper than 1:48? [406.1, 405.3]</p>	<p><input type="checkbox"/> Yes <input type="checkbox"/> No</p> <p>Measurement:</p>		

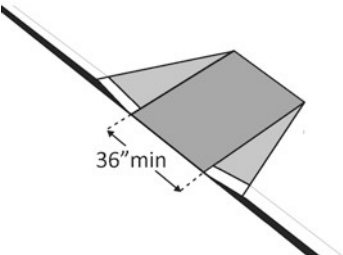
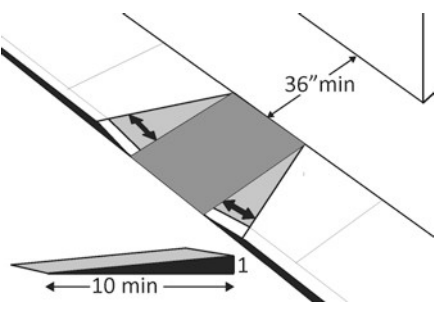
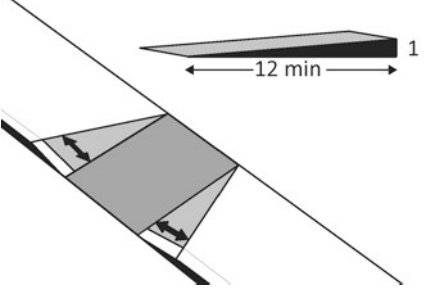
<p>5.18 Is the curb ramp, excluding flares, at least 36 inches wide? [406.1, 405.5]</p>	<p><input type="checkbox"/> Yes <input type="checkbox"/> No</p> <p>Measurement:</p>		
<p>5.19 At the top of the curb ramp is there a level landing (slope no steeper than 1:48 in all directions) that is at least 36 inches long and at least as wide as the curb ramp? [406.4]</p> <p>If there are curb ramp flares, are the slopes of the flares no steeper than 1:10, i.e. for every inch of height change there are at least 10 inches of flare run? [406.3]</p>	<p><input type="checkbox"/> Yes <input type="checkbox"/> No</p> <p>Measurement:</p> <p><input type="checkbox"/> Yes <input type="checkbox"/> No</p> <p>Measurement:</p>		
<p>5.20 If the landing at the top is less than 36 inches long, are there curb ramp flares? [406.4]</p> <p>Are the slopes of the flares no greater than 1:12, i.e. for every inch of height change there are at least 12 inches of flare run? [406.4]</p>	<p><input type="checkbox"/> Yes <input type="checkbox"/> No</p> <p><input type="checkbox"/> Yes <input type="checkbox"/> No</p> <p>Measurement:</p>		
<p>Accessible Play Components <input checked="" type="checkbox"/> Yes <input type="checkbox"/> No</p>			
<p>5.21 <u>Ground Level Play Components</u> Is there an accessible route to at least one of each type of ground level play component?</p> <p>Notes:</p> <ol style="list-style-type: none"> 1. A play component is an element designed to generate play, socialization and learning. 2. Ground level play components are components that can be approached and exited at 	<p><input checked="" type="checkbox"/> Yes <input type="checkbox"/> No</p>		

ADA Checklist for Existing Facilities - Parks

<p>ground level. Examples include rockers, swings, diggers and stand-alone slides.</p>			
<p>5.22 <u>Elevated Play Components</u> Are there any accessible elevated play components? If so, is there an accessible route to the components?</p>	<p><input type="checkbox"/> Yes <input checked="" type="checkbox"/> No <input type="checkbox"/> Yes <input checked="" type="checkbox"/> No</p>		
<p>5.23 Is the vertical clearance of the accessible route at least 80 inches above the ground surface? Note: Objects below 80 inches may not protrude into the accessible route.</p>	<p><input checked="" type="checkbox"/> Yes <input type="checkbox"/> No</p>		
<p>Pavilion <input type="checkbox"/> Yes <input checked="" type="checkbox"/> No</p>			
<p>5.24 Is there an accessible route that is stable, firm and slip-resistant? [302.1]</p>	<p><input type="checkbox"/> Yes <input type="checkbox"/> No</p>		
<p>5.25 Is the route at least 36 inches wide? [403.5.1]</p>	<p><input type="checkbox"/> Yes <input type="checkbox"/> No</p>		
<p>5.26 Is the running slope no steeper than 1:20, i.e. for every inch of height change there are at least 20 inches of route run? [403.3] Note: If the running slope is steeper than 1:20, treat as a ramp and add features such as edge protection and handrails.</p>	<p><input type="checkbox"/> Yes <input type="checkbox"/> No Measurement:</p>		

ADA Checklist for Existing Facilities - Parks

<p>5.27 Is the cross slope no steeper than 1:48? [403.3]</p>	<p><input type="checkbox"/> Yes <input type="checkbox"/> No</p> <p>Measurement:</p>	
---	---	--

Benches Yes No

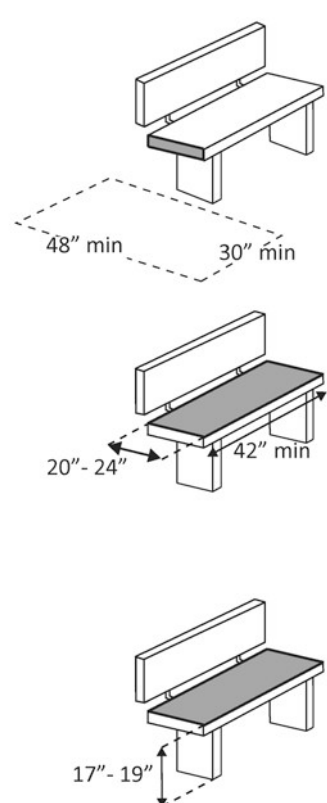
<p>5.28 Is there a clear floor space at least 30 inches wide by at least 48 inches long at the end of the bench and parallel to the short axis of the bench?</p> <p>Is the bench seat at least 42 inches long and no less than 20 inches and no greater than 24 inches deep?</p> <p>Does the bench have back support or is it affixed to a wall?</p> <p>Is the top of the bench seat no less than 17 inches and no greater than 19 inches above the floor? [903]</p>	<p><input checked="" type="checkbox"/> Yes <input type="checkbox"/> No</p> <p>Measurement:</p> <p><input checked="" type="checkbox"/> Yes <input type="checkbox"/> No</p> <p>Measurement:</p> <p>70"</p> <p><input checked="" type="checkbox"/> Yes <input type="checkbox"/> No</p> <p><input checked="" type="checkbox"/> Yes <input type="checkbox"/> No</p> <p>Measurement:</p> <p>17"</p>	
---	---	---

Dining Tables Yes No

<p>5.28 Are at least 5 percent, but not less than one, of the dining surfaces for the seating and standing spaces accessible?</p> <p>Is/are the accessible space(s) distributed throughout the facility and located on an accessible route?</p>	<p><input checked="" type="checkbox"/> Yes <input type="checkbox"/> No</p> <p>Total #: 3 Accessible #: 1</p> <p><input checked="" type="checkbox"/> Yes <input type="checkbox"/> No</p>	
--	---	--

ADA Checklist for Existing Facilities - Parks

City of Grand Rapids ADA Transition Plan

Building: Maplewood Park

Location: SE 4th Ave and SE 14th Street

Date: 10/1/19

Evaluated By: Dom DeGuseppi

Priority 5 - Parks

5.1 Is there at least one route from site arrival points (parking, passenger loading zones, public sidewalks and public transportation stops) that does not require the use of stairs? [See 2010 ADA Standards for Accessible Design – 206.2.1]

Yes No

If yes, location of route:

Parking Yes No

5.2 If parking is provided for the public, are an adequate number of accessible spaces provided? [208.2]

Yes No

Total #: **5**
Accessible #: **0**

Total Spaces	Accessible Spaces
1 - 25	1
26 - 50	2
51 - 75	3
76 - 100	4
100+ see 2010 Standards 208.2	

Dirt lot, no markings except for railroad ties

5.3 Are accessible spaces at least 8 feet wide with an access aisle at least 8 feet wide? [502.2, 502.3]



Yes No

Measurement:

Note: Two spaces may share an access aisle. Check state/local requirements;

Not marked

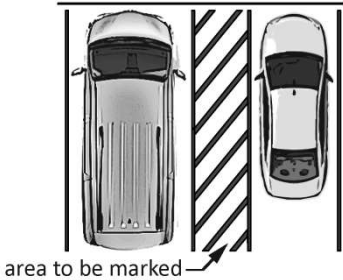
ADA Checklist for Existing Facilities - Parks

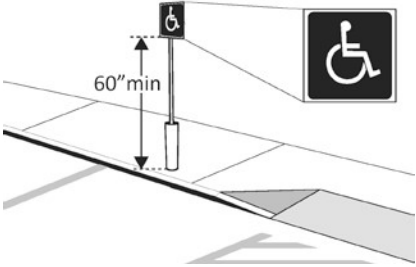
	some specify that each space have its own aisle.			
5.4	<p>Are the access aisles marked with signage and surface painting so as to discourage parking in them? [502.3.3]</p> <p>Note: The marking method and color may be addressed by state/local requirements.</p>	<input type="checkbox"/> Yes <input checked="" type="checkbox"/> No		
5.5	<p>Is the slope of the accessible parking spaces and access aisles no steeper than 1:48 in all directions? [502.4]</p>	<input type="checkbox"/> Yes <input checked="" type="checkbox"/> No Measurement: 5.8%		
5.6	<p>Do the access aisles adjoin an accessible route? [502.3]</p>	<input type="checkbox"/> Yes <input checked="" type="checkbox"/> No		
5.7	<p>Are accessible spaces identified with a sign that includes the International Symbol of Accessibility?</p> <p>Is the bottom of the sign at least 60 inches and not greater than 66 inches above the ground? [502.6]</p>	<input type="checkbox"/> Yes <input checked="" type="checkbox"/> No <input type="checkbox"/> Yes <input checked="" type="checkbox"/> No Measurement:		
5.8	<p>Of the total parking spaces, are the accessible spaces located on the closest accessible route to the accessible entrance(s)? [208.3.1]</p>	<input type="checkbox"/> Yes <input checked="" type="checkbox"/> No		

Exterior Accessible Route

5.9 Is the route stable, firm and slip-resistant?
[302.1] Yes No

5.10 Is the route at least 36 inches wide?
[403.5.1] Yes No

Measurement:

Note: The accessible route can narrow to 32 inches min. for a max. of 24 inches. These narrower portions of the route must be at least 48 inches from each other.

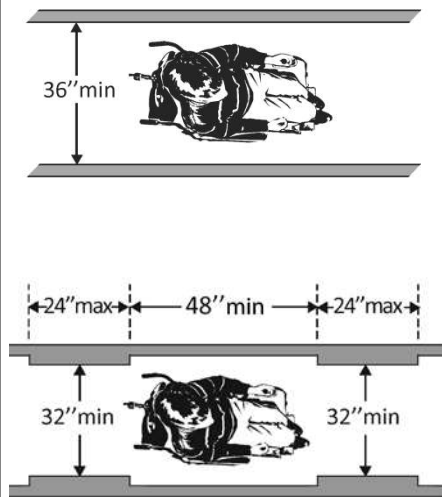

5.11 If the route is greater than 200 feet in length and less than 60 inches wide, is there a passing space no less than 60 x 60 inches?
[403.5.3] Yes No

Measurement:

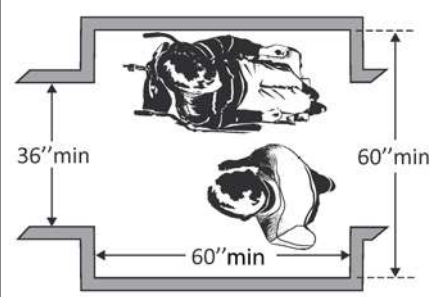

5.12 If there are grates or openings on the route, are the openings no larger than 1/2 inches?
[403.5.3]

If the route is greater than 200 feet in length and less than 60 inches wide, is there a passing space no less than 60 x 60 inches?
[403.5.3]

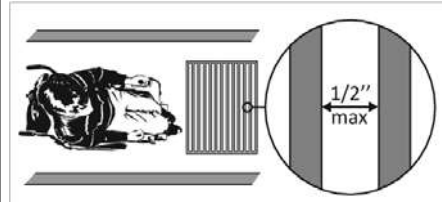

ADA Checklist for Existing Facilities - Parks

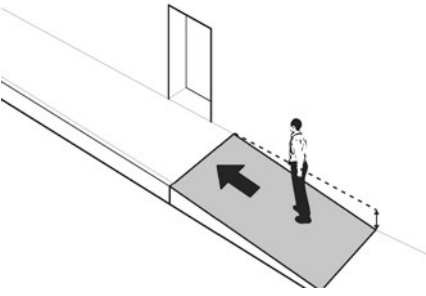
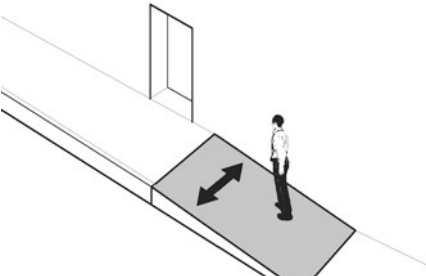
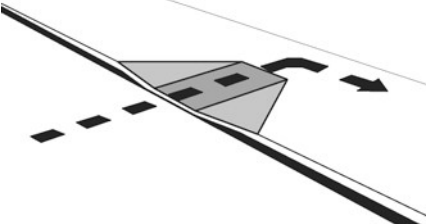
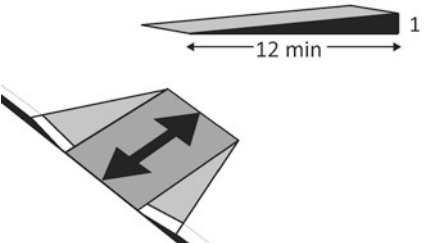
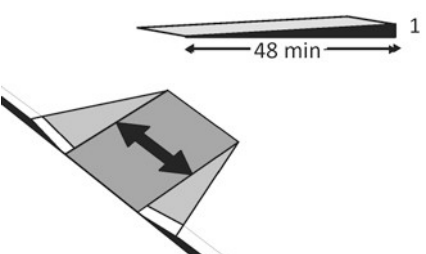
<p>5.13 Is the running slope no steeper than 1:20, i.e. for every inch of height change there are at least 20 inches of route run? [403.3]</p> <p>Note: If the running slope is steeper than 1:20, treat as a ramp and add features such as edge protection and handrails.</p>	<p><input type="checkbox"/> Yes <input checked="" type="checkbox"/> No</p> <p>Measurement:</p>		
<p>5.14 Is the cross slope no steeper than 1:48? [403.3]</p>	<p><input type="checkbox"/> Yes <input checked="" type="checkbox"/> No</p> <p>Measurement:</p>		
<p>Curb Ramps <input type="checkbox"/> Yes <input checked="" type="checkbox"/> No</p>			
<p>5.15 If the accessible route crosses a curb, is there a curb ramp? [402.2]</p>	<p><input type="checkbox"/> Yes <input type="checkbox"/> No</p>		
<p>5.16 Is the running slope of the curb ramp no steeper than 1:12, i.e. for every inch of height change there are at least 12 inches of curb ramp run? [406.1, 405.2]</p>	<p><input type="checkbox"/> Yes <input type="checkbox"/> No</p> <p>Measurement:</p>		
<p>5.17 Is the cross slope of the curb ramp, excluding flares, no steeper than 1:48? [406.1, 405.3]</p>	<p><input type="checkbox"/> Yes <input type="checkbox"/> No</p> <p>Measurement:</p>		

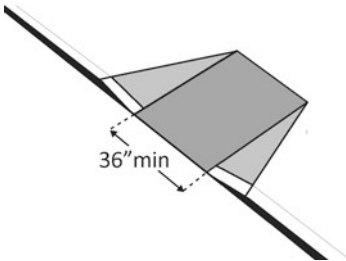
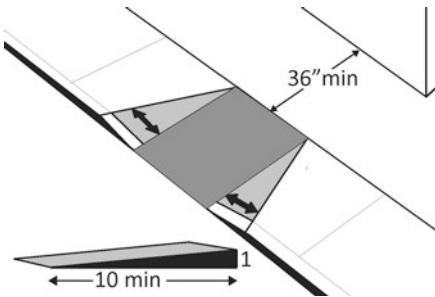
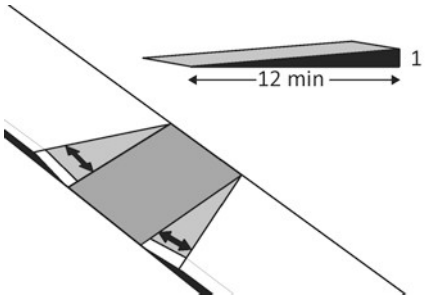
<p>5.18 Is the curb ramp, excluding flares, at least 36 inches wide? [406.1, 405.5]</p>	<p><input type="checkbox"/> Yes <input type="checkbox"/> No</p> <p>Measurement:</p>		
<p>5.19 At the top of the curb ramp is there a level landing (slope no steeper than 1:48 in all directions) that is at least 36 inches long and at least as wide as the curb ramp? [406.4]</p> <p>If there are curb ramp flares, are the slopes of the flares no steeper than 1:10, i.e. for every inch of height change there are at least 10 inches of flare run? [406.3]</p>	<p><input type="checkbox"/> Yes <input type="checkbox"/> No</p> <p>Measurement:</p> <p><input type="checkbox"/> Yes <input type="checkbox"/> No</p> <p>Measurement:</p>		
<p>5.20 If the landing at the top is less than 36 inches long, are there curb ramp flares? [406.4]</p> <p>Are the slopes of the flares no greater than 1:12, i.e. for every inch of height change there are at least 12 inches of flare run? [406.4]</p>	<p><input type="checkbox"/> Yes <input type="checkbox"/> No</p> <p><input type="checkbox"/> Yes <input type="checkbox"/> No</p> <p>Measurement:</p>		
<p>Accessible Play Components <input checked="" type="checkbox"/> Yes <input type="checkbox"/> No</p>			
<p>5.21 <u>Ground Level Play Components</u> Is there an accessible route to at least one of each type of ground level play component?</p> <p>Notes:</p> <ol style="list-style-type: none"> 1. A play component is an element designed to generate play, socialization and learning. 2. Ground level play components are components that can be approached and exited at 	<p><input checked="" type="checkbox"/> Yes <input type="checkbox"/> No</p>		

ADA Checklist for Existing Facilities - Parks

<p>ground level. Examples include rockers, swings, diggers and stand-alone slides.</p>			
<p>5.22 <u>Elevated Play Components</u> Are there any accessible elevated play components?</p> <p>If so, is there an accessible route to the components?</p>	<p><input type="checkbox"/> Yes <input checked="" type="checkbox"/> No</p> <p><input type="checkbox"/> Yes <input checked="" type="checkbox"/> No</p>		
<p>5.23 Is the vertical clearance of the accessible route at least 80 inches above the ground surface?</p> <p>Note: Objects below 80 inches may not protrude into the accessible route.</p>	<p><input type="checkbox"/> Yes <input checked="" type="checkbox"/> No</p>		
<p>Pavilion <input type="checkbox"/> Yes <input checked="" type="checkbox"/> No</p>			
<p>5.24 Is there an accessible route that is stable, firm and slip-resistant? [302.1]</p>	<p><input type="checkbox"/> Yes <input type="checkbox"/> No</p>		
<p>5.25 Is the route at least 36 inches wide? [403.5.1]</p>	<p><input type="checkbox"/> Yes <input type="checkbox"/> No</p>		
<p>5.26 Is the running slope no steeper than 1:20, i.e. for every inch of height change there are at least 20 inches of route run? [403.3]</p> <p>Note: If the running slope is steeper than 1:20, treat as a ramp and add features such as edge protection and handrails.</p>	<p><input type="checkbox"/> Yes <input type="checkbox"/> No</p> <p>Measurement:</p>		

ADA Checklist for Existing Facilities - Parks

<p>5.27 Is the cross slope no steeper than 1:48? [403.3]</p>	<p><input type="checkbox"/> Yes <input type="checkbox"/> No</p> <p>Measurement:</p>	
---	---	--

Benches Yes No

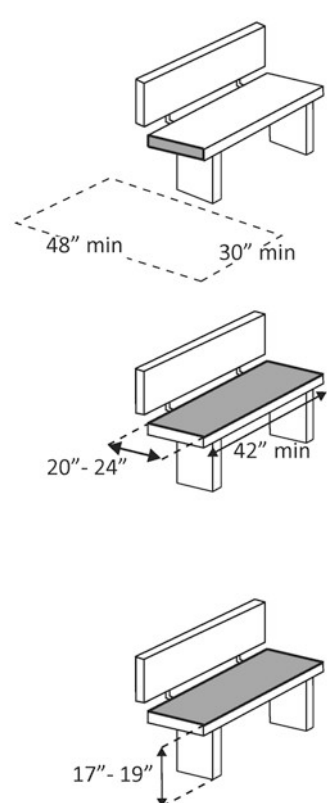
<p>5.28 Is there a clear floor space at least 30 inches wide by at least 48 inches long at the end of the bench and parallel to the short axis of the bench?</p> <p>Is the bench seat at least 42 inches long and no less than 20 inches and no greater than 24 inches deep?</p> <p>Does the bench have back support or is it affixed to a wall?</p> <p>Is the top of the bench seat no less than 17 inches and no greater than 19 inches above the floor? [903]</p>	<p><input checked="" type="checkbox"/> Yes <input type="checkbox"/> No</p> <p>Measurement:</p> <p><input type="checkbox"/> Yes <input checked="" type="checkbox"/> No</p> <p>Measurement:</p> <p>70"</p> <p><input checked="" type="checkbox"/> Yes <input type="checkbox"/> No</p> <p><input checked="" type="checkbox"/> Yes <input type="checkbox"/> No</p> <p>Measurement:</p> <p>17"</p>	
---	---	---

Dining Tables Yes No

<p>5.28 Are at least 5 percent, but not less than one, of the dining surfaces for the seating and standing spaces accessible?</p> <p>Is/are the accessible space(s) distributed throughout the facility and located on an accessible route?</p>	<p><input checked="" type="checkbox"/> Yes <input type="checkbox"/> No</p> <p>Total #: 4 Accessible #: 1</p> <p><input type="checkbox"/> Yes <input checked="" type="checkbox"/> No</p>	
--	---	--

ADA Checklist for Existing Facilities - Parks

City of Grand Rapids ADA Transition Plan

Building: McGowan Park

Location: _____

Date: 10/2/19

Evaluated By: Dom DeGuseppi

Priority 5 - Parks

5.1 Is there at least one route from site arrival points (parking, passenger loading zones, public sidewalks and public transportation stops) that does not require the use of stairs? [See 2010 ADA Standards for Accessible Design – 206.2.1]

Yes No

If yes, location of route:

Parking Yes No

5.2 If parking is provided for the public, are an adequate number of accessible spaces provided? [208.2]	<input type="checkbox"/> Yes <input checked="" type="checkbox"/> No	Total #: Accessible #:	Total Spaces	Accessible Spaces	Street Parking
			1 - 25	1	
			26 - 50	2	
			51 - 75	3	
			76 - 100	4	
			100+ see 2010 Standards 208.2		



5.3 Are accessible spaces at least 8 feet wide with an access aisle at least 8 feet wide? [502.2, 502.3]

Yes No

Measurement:

Note: Two spaces may share an access aisle. Check state/local requirements;

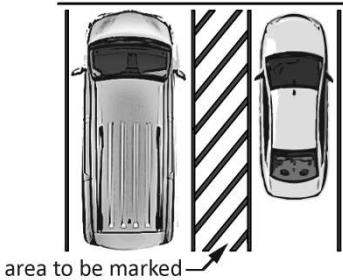
ADA Checklist for Existing Facilities - Parks

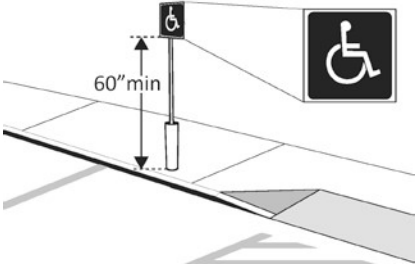
	some specify that each space have its own aisle.		
<p>5.4 Are the access aisles marked with signage and surface painting so as to discourage parking in them? [502.3.3]</p> <p>Note: The marking method and color may be addressed by state/local requirements.</p>	<p><input type="checkbox"/> Yes <input checked="" type="checkbox"/> No</p>		
<p>5.5 Is the slope of the accessible parking spaces and access aisles no steeper than 1:48 in all directions? [502.4]</p>	<p><input type="checkbox"/> Yes <input checked="" type="checkbox"/> No</p> <p>Measurement: NA</p>		
<p>5.6 Do the access aisles adjoin an accessible route? [502.3]</p>	<p><input type="checkbox"/> Yes <input checked="" type="checkbox"/> No</p>		
<p>5.7 Are accessible spaces identified with a sign that includes the International Symbol of Accessibility?</p> <p>Is the bottom of the sign at least 60 inches and not greater than 66 inches above the ground? [502.6]</p>	<p><input type="checkbox"/> Yes <input checked="" type="checkbox"/> No</p> <p><input type="checkbox"/> Yes <input checked="" type="checkbox"/> No</p> <p>Measurement:</p>		
<p>5.8 Of the total parking spaces, are the accessible spaces located on the closest accessible route to the accessible entrance(s)? [208.3.1]</p>	<p><input type="checkbox"/> Yes <input checked="" type="checkbox"/> No</p>		

Exterior Accessible Route

5.9 Is the route stable, firm and slip-resistant?
[302.1] Yes No

5.10 Is the route at least 36 inches wide?
[403.5.1] Yes No
Measurement:
NA

Note: The accessible route can narrow to 32 inches min. for a max. of 24 inches. These narrower portions of the route must be at least 48 inches from each other.

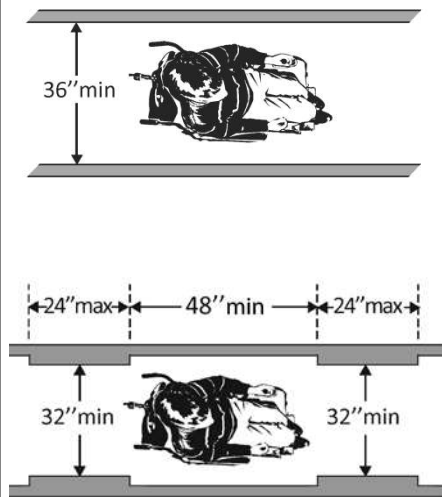

5.11 If the route is greater than 200 feet in length and less than 60 inches wide, is there a passing space no less than 60 x 60 inches?
[403.5.3] Yes No
Measurement:
NA

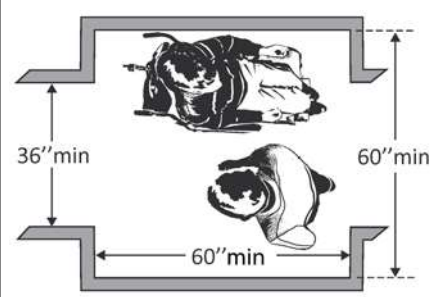

5.12 If there are grates or openings on the route, are the openings no larger than 1/2 inches?
If the route is greater than 200 feet in length and less than 60 inches wide, is there a passing space no less than 60 x 60 inches?
[403.5.3]

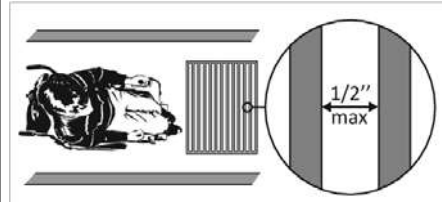

ADA Checklist for Existing Facilities - Parks

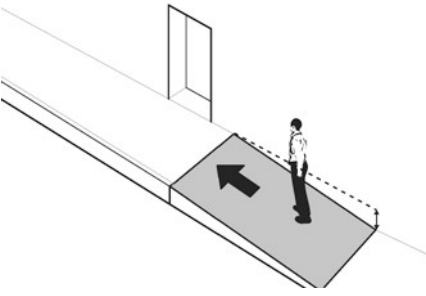
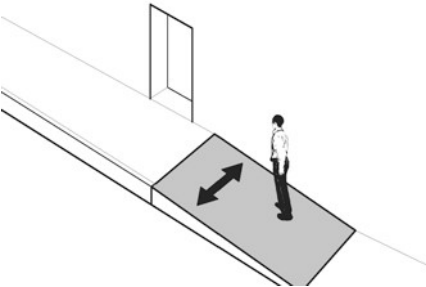
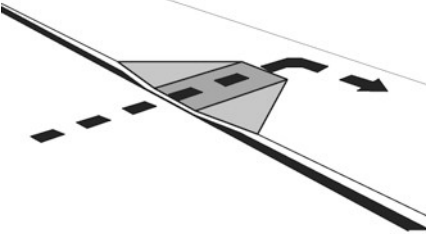
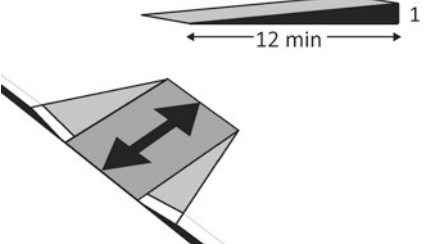
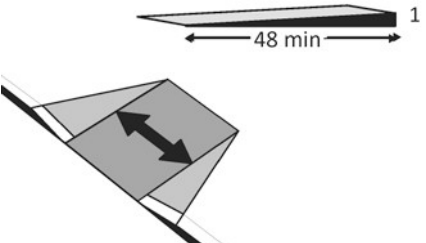
<p>5.13 Is the running slope no steeper than 1:20, i.e. for every inch of height change there are at least 20 inches of route run? [403.3]</p> <p>Note: If the running slope is steeper than 1:20, treat as a ramp and add features such as edge protection and handrails.</p>	<p><input type="checkbox"/> Yes <input type="checkbox"/> No</p> <p>Measurement: NA</p>		
<p>5.14 Is the cross slope no steeper than 1:48? [403.3]</p>	<p><input type="checkbox"/> Yes <input type="checkbox"/> No</p> <p>Measurement: NA</p>		
<p>Curb Ramps <input type="checkbox"/> Yes <input checked="" type="checkbox"/> No</p>			
<p>5.15 If the accessible route crosses a curb, is there a curb ramp? [402.2]</p>	<p><input type="checkbox"/> Yes <input checked="" type="checkbox"/> No</p>		
<p>5.16 Is the running slope of the curb ramp no steeper than 1:12, i.e. for every inch of height change there are at least 12 inches of curb ramp run? [406.1, 405.2]</p>	<p><input type="checkbox"/> Yes <input type="checkbox"/> No</p> <p>Measurement: NA</p>		
<p>5.17 Is the cross slope of the curb ramp, excluding flares, no steeper than 1:48? [406.1, 405.3]</p>	<p><input type="checkbox"/> Yes <input type="checkbox"/> No</p> <p>Measurement: NA</p>		

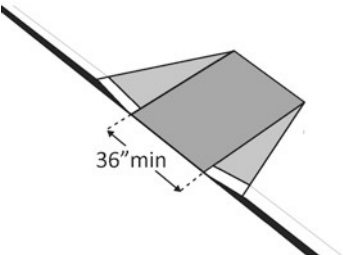
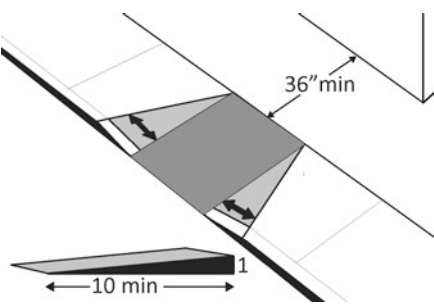
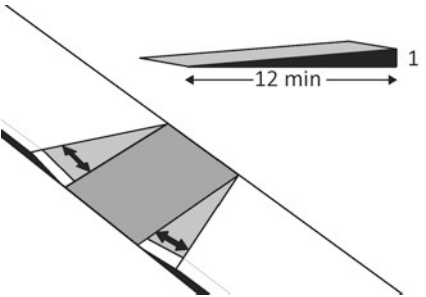
<p>5.18 Is the curb ramp, excluding flares, at least 36 inches wide? [406.1, 405.5]</p>	<p><input checked="" type="checkbox"/> Yes <input type="checkbox"/> No</p> <p>Measurement: 44"</p>		
<p>5.19 At the top of the curb ramp is there a level landing (slope no steeper than 1:48 in all directions) that is at least 36 inches long and at least as wide as the curb ramp? [406.4]</p> <p>If there are curb ramp flares, are the slopes of the flares no steeper than 1:10, i.e. for every inch of height change there are at least 10 inches of flare run? [406.3]</p>	<p><input type="checkbox"/> Yes <input type="checkbox"/> No</p> <p>Measurement: NA</p> <p><input type="checkbox"/> Yes <input type="checkbox"/> No</p> <p>Measurement: NA</p>		
<p>5.20 If the landing at the top is less than 36 inches long, are there curb ramp flares? Are the slopes of the flares no greater than 1:12, i.e. for every inch of height change there are at least 12 inches of flare run? [406.4]</p>	<p><input type="checkbox"/> Yes <input checked="" type="checkbox"/> No</p> <p><input type="checkbox"/> Yes <input checked="" type="checkbox"/> No</p> <p>Measurement:</p>		
<p>Accessible Play Components <input type="checkbox"/> Yes <input checked="" type="checkbox"/> No</p>			
<p>5.21 <u>Ground Level Play Components</u> Is there an accessible route to at least one of each type of ground level play component?</p> <p>Notes:</p> <ol style="list-style-type: none"> 1. A play component is an element designed to generate play, socialization and learning. 2. Ground level play components are components that can be approached and exited at 	<p><input type="checkbox"/> Yes <input checked="" type="checkbox"/> No</p>		

ADA Checklist for Existing Facilities - Parks

<p>ground level. Examples include rockers, swings, diggers and stand-alone slides.</p>			
<p>5.22 <u>Elevated Play Components</u> Are there any accessible elevated play components?</p> <p>If so, is there an accessible route to the components?</p>	<p><input type="checkbox"/> Yes <input checked="" type="checkbox"/> No</p> <p><input type="checkbox"/> Yes <input checked="" type="checkbox"/> No</p>		
<p>5.23 Is the vertical clearance of the accessible route at least 80 inches above the ground surface?</p> <p>Note: Objects below 80 inches may not protrude into the accessible route.</p>	<p><input checked="" type="checkbox"/> Yes <input type="checkbox"/> No</p>		
<p>Pavilion <input type="checkbox"/> Yes <input checked="" type="checkbox"/> No</p>			
<p>5.24 Is there an accessible route that is stable, firm and slip-resistant? [302.1]</p>	<p><input type="checkbox"/> Yes <input type="checkbox"/> No</p>		
<p>5.25 Is the route at least 36 inches wide? [403.5.1]</p>	<p><input type="checkbox"/> Yes <input type="checkbox"/> No</p>		
<p>5.26 Is the running slope no steeper than 1:20, i.e. for every inch of height change there are at least 20 inches of route run? [403.3]</p> <p>Note: If the running slope is steeper than 1:20, treat as a ramp and add features such as edge protection and handrails.</p>	<p><input type="checkbox"/> Yes <input type="checkbox"/> No</p> <p>Measurement:</p>		

ADA Checklist for Existing Facilities - Parks

<p>5.27 Is the cross slope no steeper than 1:48? [403.3]</p>	<p><input type="checkbox"/> Yes <input type="checkbox"/> No</p> <p>Measurement:</p>	
---	---	--

Benches Yes No

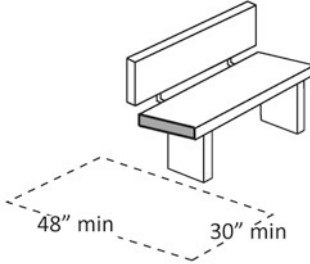
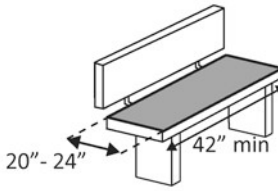
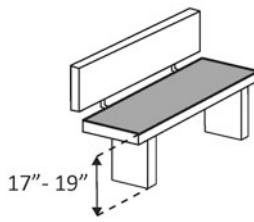
<p>5.28 Is there a clear floor space at least 30 inches wide by at least 48 inches long at the end of the bench and parallel to the short axis of the bench?</p> <p>Is the bench seat at least 42 inches long and no less than 20 inches and no greater than 24 inches deep?</p> <p>Does the bench have back support or is it affixed to a wall?</p> <p>Is the top of the bench seat no less than 17 inches and no greater than 19 inches above the floor? [903]</p>	<p><input checked="" type="checkbox"/> Yes <input type="checkbox"/> No</p> <p>Measurement:</p> <p><input checked="" type="checkbox"/> Yes <input type="checkbox"/> No</p> <p>Measurement:</p> <p>68"</p> <p><input checked="" type="checkbox"/> Yes <input type="checkbox"/> No</p> <p><input checked="" type="checkbox"/> Yes <input type="checkbox"/> No</p> <p>Measurement:</p> <p>19"</p>	<p>Ground</p>   	
---	---	---	--

Dining Tables Yes No

<p>5.28 Are at least 5 percent, but not less than one, of the dining surfaces for the seating and standing spaces accessible?</p> <p>Is/are the accessible space(s) distributed throughout the facility and located on an accessible route?</p>	<p><input checked="" type="checkbox"/> Yes <input type="checkbox"/> No</p> <p>Total #: 2 Accessible #: 1</p> <p><input checked="" type="checkbox"/> Yes <input type="checkbox"/> No</p>	
--	---	--

ADA Checklist for Existing Facilities - Parks

City of Grand Rapids ADA Transition Plan

Building: McKinney Lake Landing

Location: _____

Date: 10/8/19

Evaluated By: Dom DeGuseppi

Priority 5 - Parks



5.1	Is there at least one route from site arrival points (parking, passenger loading zones, public sidewalks and public transportation stops) that does not require the use of stairs? [See 2010 ADA Standards for Accessible Design – 206.2.1]	<input checked="" type="checkbox"/> Yes <input type="checkbox"/> No If yes, location of route:		
------------	--	---	--	--

Parking Yes No

5.2	If parking is provided for the public, are an adequate number of accessible spaces provided? [208.2]	<input type="checkbox"/> Yes <input checked="" type="checkbox"/> No Total #: Accessible #:	Total Spaces	Accessible Spaces	Gravel Lot
			1 - 25	1	
			26 - 50	2	
			51 - 75	3	
			76 - 100	4	
			100+ see 2010 Standards 208.2		

5.3	Are accessible spaces at least 8 feet wide with an access aisle at least 8 feet wide? [502.2, 502.3] Note: Two spaces may share an access aisle. Check state/local requirements;	<input type="checkbox"/> Yes <input checked="" type="checkbox"/> No Measurement:		
------------	--	---	--	--

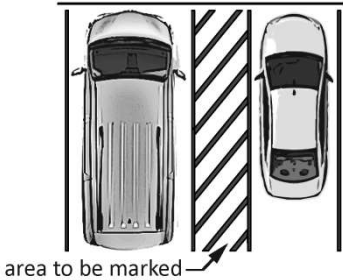
ADA Checklist for Existing Facilities - Parks

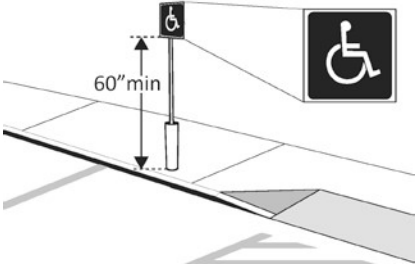
	some specify that each space have its own aisle.		
<p>5.4 Are the access aisles marked with signage and surface painting so as to discourage parking in them? [502.3.3]</p> <p>Note: The marking method and color may be addressed by state/local requirements.</p>	<p><input type="checkbox"/> Yes <input checked="" type="checkbox"/> No</p>		
<p>5.5 Is the slope of the accessible parking spaces and access aisles no steeper than 1:48 in all directions? [502.4]</p>	<p><input type="checkbox"/> Yes <input checked="" type="checkbox"/> No</p> <p>Measurement:</p>		
<p>5.6 Do the access aisles adjoin an accessible route? [502.3]</p>	<p><input type="checkbox"/> Yes <input checked="" type="checkbox"/> No</p>		
<p>5.7 Are accessible spaces identified with a sign that includes the International Symbol of Accessibility?</p> <p>Is the bottom of the sign at least 60 inches and not greater than 66 inches above the ground? [502.6]</p>	<p><input type="checkbox"/> Yes <input checked="" type="checkbox"/> No</p> <p><input type="checkbox"/> Yes <input checked="" type="checkbox"/> No</p> <p>Measurement:</p>		
<p>5.8 Of the total parking spaces, are the accessible spaces located on the closest accessible route to the accessible entrance(s)? [208.3.1]</p>	<p><input type="checkbox"/> Yes <input checked="" type="checkbox"/> No</p>		

Exterior Accessible Route

5.9 Is the route stable, firm and slip-resistant? [302.1] Yes No

5.10 Is the route at least 36 inches wide? [403.5.1] Yes No
Measurement:

Note: The accessible route can narrow to 32 inches min. for a max. of 24 inches. These narrower portions of the route must be at least 48 inches from each other.

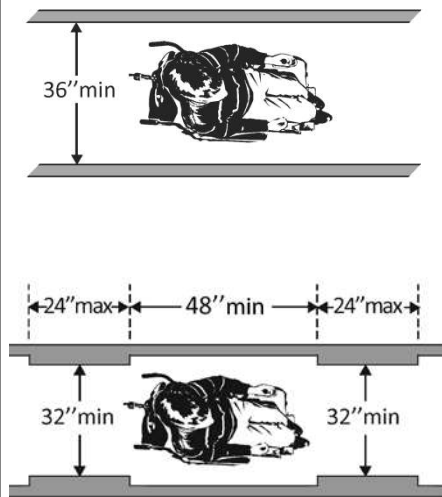

5.11 If the route is greater than 200 feet in length and less than 60 inches wide, is there a passing space no less than 60 x 60 inches? [403.5.3] Yes No
Measurement:

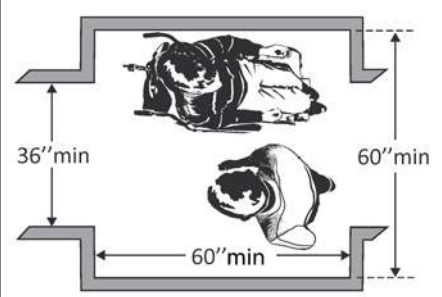

5.12 If there are grates or openings on the route, are the openings no larger than 1/2 inches? [403.5.3] If the route is greater than 200 feet in length and less than 60 inches wide, is there a passing space no less than 60 x 60 inches?

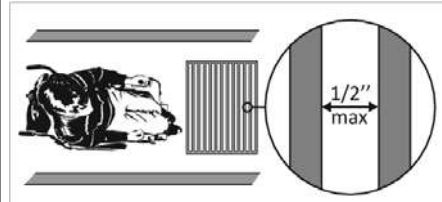

ADA Checklist for Existing Facilities - Parks

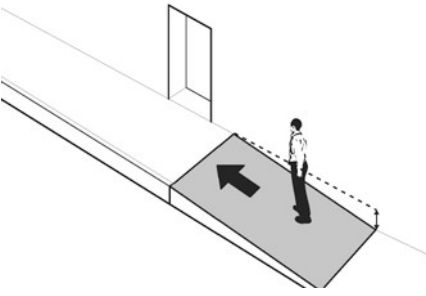
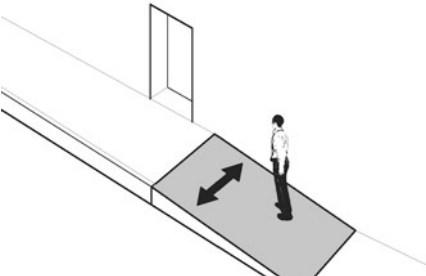
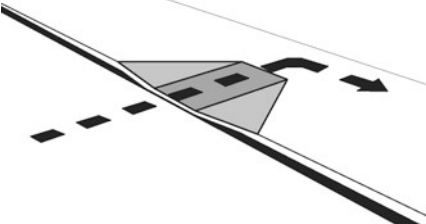
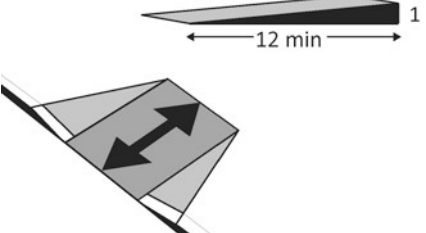
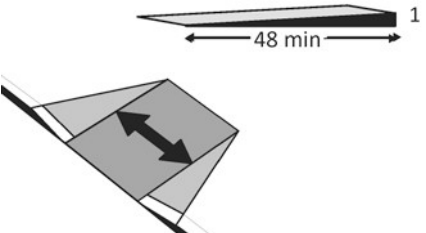
<p>5.13 Is the running slope no steeper than 1:20, i.e. for every inch of height change there are at least 20 inches of route run? [403.3]</p> <p>Note: If the running slope is steeper than 1:20, treat as a ramp and add features such as edge protection and handrails.</p>	<p><input type="checkbox"/> Yes <input checked="" type="checkbox"/> No</p> <p>Measurement:</p>		
<p>5.14 Is the cross slope no steeper than 1:48? [403.3]</p>	<p><input type="checkbox"/> Yes <input checked="" type="checkbox"/> No</p> <p>Measurement:</p>		
<p>Curb Ramps <input type="checkbox"/> Yes <input checked="" type="checkbox"/> No</p>			
<p>5.15 If the accessible route crosses a curb, is there a curb ramp? [402.2]</p>	<p><input type="checkbox"/> Yes <input type="checkbox"/> No</p>		
<p>5.16 Is the running slope of the curb ramp no steeper than 1:12, i.e. for every inch of height change there are at least 12 inches of curb ramp run? [406.1, 405.2]</p>	<p><input type="checkbox"/> Yes <input type="checkbox"/> No</p> <p>Measurement:</p>		
<p>5.17 Is the cross slope of the curb ramp, excluding flares, no steeper than 1:48? [406.1, 405.3]</p>	<p><input type="checkbox"/> Yes <input type="checkbox"/> No</p> <p>Measurement:</p>		

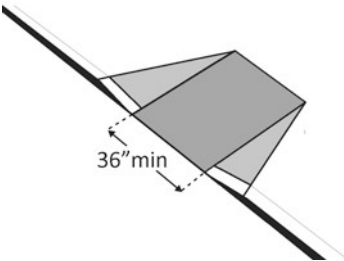
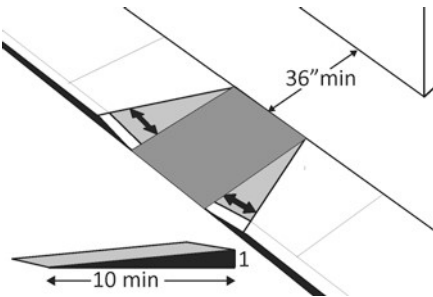
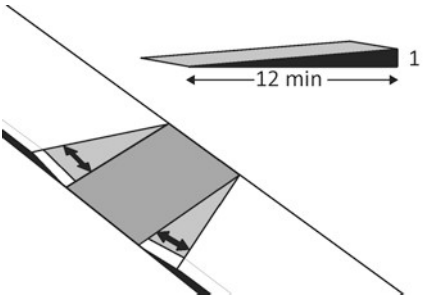
<p>5.18 Is the curb ramp, excluding flares, at least 36 inches wide? [406.1, 405.5]</p>	<p><input type="checkbox"/> Yes <input type="checkbox"/> No</p> <p>Measurement:</p>		
<p>5.19 At the top of the curb ramp is there a level landing (slope no steeper than 1:48 in all directions) that is at least 36 inches long and at least as wide as the curb ramp? [406.4]</p> <p>If there are curb ramp flares, are the slopes of the flares no steeper than 1:10, i.e. for every inch of height change there are at least 10 inches of flare run? [406.3]</p>	<p><input type="checkbox"/> Yes <input type="checkbox"/> No</p> <p>Measurement:</p> <p><input type="checkbox"/> Yes <input type="checkbox"/> No</p> <p>Measurement:</p>		
<p>5.20 If the landing at the top is less than 36 inches long, are there curb ramp flares? [406.4]</p> <p>Are the slopes of the flares no greater than 1:12, i.e. for every inch of height change there are at least 12 inches of flare run? [406.4]</p>	<p><input type="checkbox"/> Yes <input type="checkbox"/> No</p> <p><input type="checkbox"/> Yes <input type="checkbox"/> No</p> <p>Measurement:</p>		
<p>Accessible Play Components <input type="checkbox"/> Yes <input checked="" type="checkbox"/> No</p>			
<p>5.21 <u>Ground Level Play Components</u> Is there an accessible route to at least one of each type of ground level play component?</p> <p>Notes:</p> <ol style="list-style-type: none"> 1. A play component is an element designed to generate play, socialization and learning. 2. Ground level play components are components that can be approached and exited at 	<p><input type="checkbox"/> Yes <input type="checkbox"/> No</p>		

ADA Checklist for Existing Facilities - Parks

<p>ground level. Examples include rockers, swings, diggers and stand-alone slides.</p>			
<p>5.22 <u>Elevated Play Components</u> Are there any accessible elevated play components? If so, is there an accessible route to the components?</p>	<p><input type="checkbox"/> Yes <input type="checkbox"/> No <input type="checkbox"/> Yes <input type="checkbox"/> No</p>		
<p>5.23 Is the vertical clearance of the accessible route at least 80 inches above the ground surface? Note: Objects below 80 inches may not protrude into the accessible route.</p>	<p><input type="checkbox"/> Yes <input type="checkbox"/> No</p>		
<p>Pavilion <input type="checkbox"/> Yes <input checked="" type="checkbox"/> No</p>			
<p>5.24 Is there an accessible route that is stable, firm and slip-resistant? [302.1]</p>	<p><input type="checkbox"/> Yes <input type="checkbox"/> No</p>		
<p>5.25 Is the route at least 36 inches wide? [403.5.1]</p>	<p><input type="checkbox"/> Yes <input type="checkbox"/> No</p>		
<p>5.26 Is the running slope no steeper than 1:20, i.e. for every inch of height change there are at least 20 inches of route run? [403.3] Note: If the running slope is steeper than 1:20, treat as a ramp and add features such as edge protection and handrails.</p>	<p><input type="checkbox"/> Yes <input type="checkbox"/> No Measurement:</p>		

ADA Checklist for Existing Facilities - Parks

<p>5.27 Is the cross slope no steeper than 1:48? [403.3]</p>	<p><input type="checkbox"/> Yes <input type="checkbox"/> No</p> <p>Measurement:</p>	
---	---	--

Benches Yes No

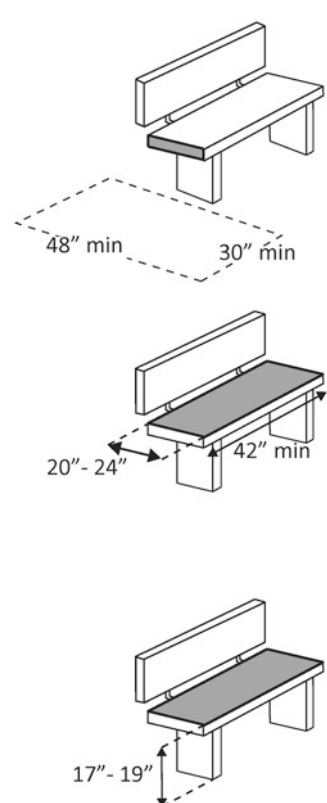
<p>5.28 Is there a clear floor space at least 30 inches wide by at least 48 inches long at the end of the bench and parallel to the short axis of the bench?</p> <p>Is the bench seat at least 42 inches long and no less than 20 inches and no greater than 24 inches deep?</p> <p>Does the bench have back support or is it affixed to a wall?</p> <p>Is the top of the bench seat no less than 17 inches and no greater than 19 inches above the floor? [903]</p>	<p><input type="checkbox"/> Yes <input type="checkbox"/> No</p> <p>Measurement:</p> <p><input type="checkbox"/> Yes <input type="checkbox"/> No</p> <p>Measurement:</p> <p><input type="checkbox"/> Yes <input type="checkbox"/> No</p> <p><input type="checkbox"/> Yes <input type="checkbox"/> No</p> <p>Measurement:</p>	 <p>The diagrams illustrate the following requirements for a bench:</p> <ul style="list-style-type: none"> A clear floor space of at least 48 inches by 30 inches at the end of the bench. A seat length of at least 42 inches and a depth of 20 to 24 inches. A seat height of 17 to 19 inches above the floor.
---	---	--

Dining Tables Yes No

<p>5.28 Are at least 5 percent, but not less than one, of the dining surfaces for the seating and standing spaces accessible?</p> <p>Is/are the accessible space(s) distributed throughout the facility and located on an accessible route?</p>	<p><input type="checkbox"/> Yes <input type="checkbox"/> No</p> <p>Total #: Accessible #:</p> <p><input type="checkbox"/> Yes <input type="checkbox"/> No</p>	
--	---	--

ADA Checklist for Existing Facilities - Parks

City of Grand Rapids ADA Transition Plan

Building: Newtons Sliding Hill

Location: _____

Date: 10/8/19

Evaluated By: Dom DeGuseppi

Priority 5 - Parks

5.1 Is there at least one route from site arrival points (parking, passenger loading zones, public sidewalks and public transportation stops) that does not require the use of stairs?
[See 2010 ADA Standards for Accessible Design – 206.2.1]

Yes No

If yes, location of route:

Parking Yes No

5.2 If parking is provided for the public, are an adequate number of accessible spaces provided? [208.2]	<input type="checkbox"/> Yes <input checked="" type="checkbox"/> No Total #: Accessible #:	Total Spaces	Accessible Spaces	Grass and gravel
		1 - 25	1	
		26 - 50	2	
		51 - 75	3	
		76 - 100	4	
		100+ see 2010 Standards 208.2		



5.3 Are accessible spaces at least 8 feet wide with an access aisle at least 8 feet wide?
[502.2, 502.3]

Yes No

Measurement:

Note: Two spaces may share an access aisle. Check state/local requirements;

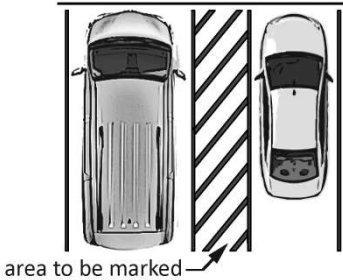
ADA Checklist for Existing Facilities - Parks

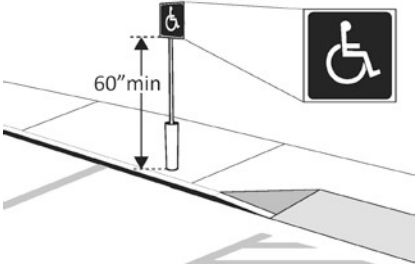
	some specify that each space have its own aisle.			
5.4	<p>Are the access aisles marked with signage and surface painting so as to discourage parking in them? [502.3.3]</p> <p>Note: The marking method and color may be addressed by state/local requirements.</p>	<input type="checkbox"/> Yes <input checked="" type="checkbox"/> No		
5.5	<p>Is the slope of the accessible parking spaces and access aisles no steeper than 1:48 in all directions? [502.4]</p>	<input type="checkbox"/> Yes <input checked="" type="checkbox"/> No Measurement:		
5.6	<p>Do the access aisles adjoin an accessible route? [502.3]</p>	<input type="checkbox"/> Yes <input checked="" type="checkbox"/> No		
5.7	<p>Are accessible spaces identified with a sign that includes the International Symbol of Accessibility?</p> <p>Is the bottom of the sign at least 60 inches and not greater than 66 inches above the ground? [502.6]</p>	<input type="checkbox"/> Yes <input checked="" type="checkbox"/> No <input type="checkbox"/> Yes <input checked="" type="checkbox"/> No Measurement:		
5.8	<p>Of the total parking spaces, are the accessible spaces located on the closest accessible route to the accessible entrance(s)? [208.3.1]</p>	<input type="checkbox"/> Yes <input checked="" type="checkbox"/> No		

Exterior Accessible Route

5.9 Is the route stable, firm and slip-resistant?
[302.1] Yes No

5.10 Is the route at least 36 inches wide?
[403.5.1] Yes No

Measurement:

Note: The accessible route can narrow to 32 inches min. for a max. of 24 inches. These narrower portions of the route must be at least 48 inches from each other.

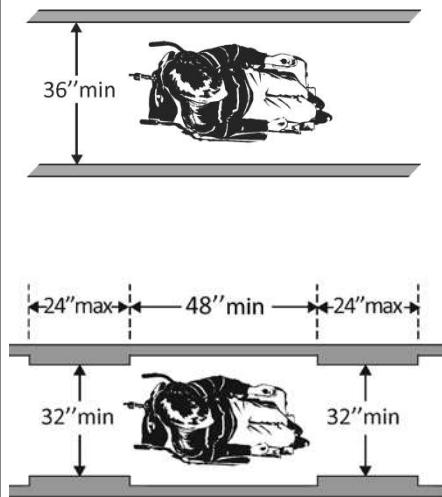

5.11 If the route is greater than 200 feet in length and less than 60 inches wide, is there a passing space no less than 60 x 60 inches?
[403.5.3] Yes No

Measurement:

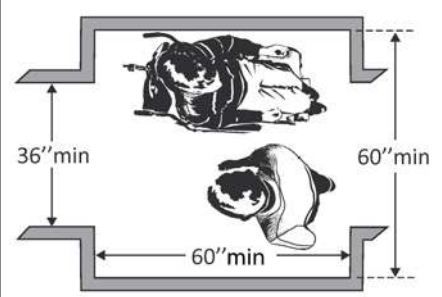

5.12 If there are grates or openings on the route, are the openings no larger than 1/2 inches?
[403.5.3]

If the route is greater than 200 feet in length and less than 60 inches wide, is there a passing space no less than 60 x 60 inches?
[403.5.3]

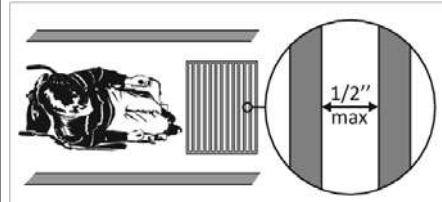

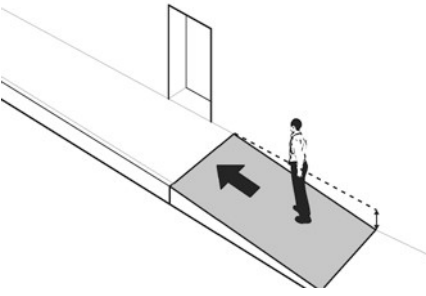
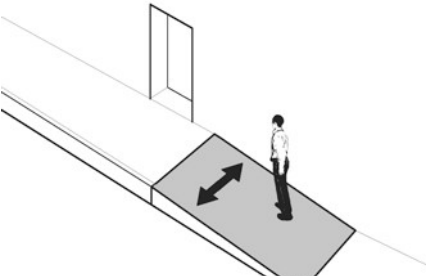
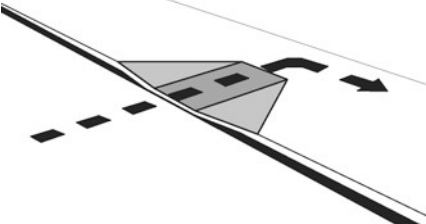
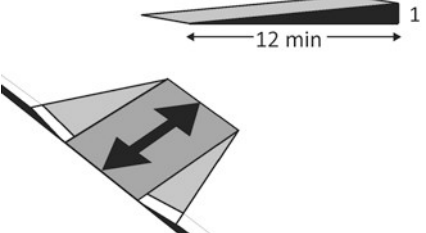
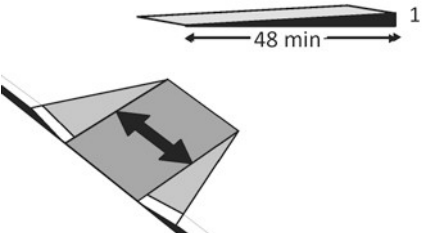
<p>5.13 Is the running slope no steeper than 1:20, i.e. for every inch of height change there are at least 20 inches of route run? [403.3]</p> <p>Note: If the running slope is steeper than 1:20, treat as a ramp and add features such as edge protection and handrails.</p>	<p><input type="checkbox"/> Yes <input checked="" type="checkbox"/> No</p> <p>Measurement:</p>		
<p>5.14 Is the cross slope no steeper than 1:48? [403.3]</p>	<p><input type="checkbox"/> Yes <input checked="" type="checkbox"/> No</p> <p>Measurement:</p>		
<p>Curb Ramps <input type="checkbox"/> Yes <input checked="" type="checkbox"/> No</p>			
<p>5.15 If the accessible route crosses a curb, is there a curb ramp? [402.2]</p>	<p><input type="checkbox"/> Yes <input type="checkbox"/> No</p>		
<p>5.16 Is the running slope of the curb ramp no steeper than 1:12, i.e. for every inch of height change there are at least 12 inches of curb ramp run? [406.1, 405.2]</p>	<p><input type="checkbox"/> Yes <input type="checkbox"/> No</p> <p>Measurement:</p>		
<p>5.17 Is the cross slope of the curb ramp, excluding flares, no steeper than 1:48? [406.1, 405.3]</p>	<p><input type="checkbox"/> Yes <input type="checkbox"/> No</p> <p>Measurement:</p>		

ADA Checklist for Existing Facilities - Parks

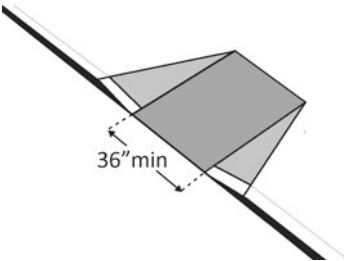
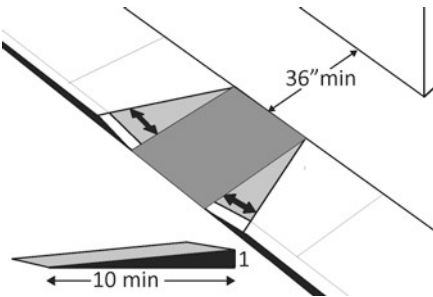
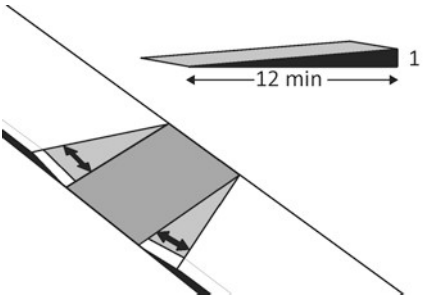
<p>5.18 Is the curb ramp, excluding flares, at least 36 inches wide? [406.1, 405.5]</p>	<p><input type="checkbox"/> Yes <input type="checkbox"/> No</p> <p>Measurement:</p>		
<p>5.19 At the top of the curb ramp is there a level landing (slope no steeper than 1:48 in all directions) that is at least 36 inches long and at least as wide as the curb ramp? [406.4]</p> <p>If there are curb ramp flares, are the slopes of the flares no steeper than 1:10, i.e. for every inch of height change there are at least 10 inches of flare run? [406.3]</p>	<p><input type="checkbox"/> Yes <input type="checkbox"/> No</p> <p>Measurement:</p> <p><input type="checkbox"/> Yes <input type="checkbox"/> No</p> <p>Measurement:</p>		
<p>5.20 If the landing at the top is less than 36 inches long, are there curb ramp flares? [406.4]</p> <p>Are the slopes of the flares no greater than 1:12, i.e. for every inch of height change there are at least 12 inches of flare run? [406.4]</p>	<p><input type="checkbox"/> Yes <input type="checkbox"/> No</p> <p><input type="checkbox"/> Yes <input type="checkbox"/> No</p> <p>Measurement:</p>		
<p>Accessible Play Components <input type="checkbox"/> Yes <input checked="" type="checkbox"/> No</p>			
<p>5.21 <u>Ground Level Play Components</u> Is there an accessible route to at least one of each type of ground level play component?</p> <p>Notes:</p> <ol style="list-style-type: none"> 1. A play component is an element designed to generate play, socialization and learning. 2. Ground level play components are components that can be approached and exited at 	<p><input type="checkbox"/> Yes <input type="checkbox"/> No</p>		

ADA Checklist for Existing Facilities - Parks

<p>ground level. Examples include rockers, swings, diggers and stand-alone slides.</p>			
<p>5.22 <u>Elevated Play Components</u> Are there any accessible elevated play components? If so, is there an accessible route to the components?</p>	<p><input type="checkbox"/> Yes <input type="checkbox"/> No <input type="checkbox"/> Yes <input type="checkbox"/> No</p>		
<p>5.23 Is the vertical clearance of the accessible route at least 80 inches above the ground surface? Note: Objects below 80 inches may not protrude into the accessible route.</p>	<p><input type="checkbox"/> Yes <input type="checkbox"/> No</p>		
<p>Pavilion <input type="checkbox"/> Yes <input checked="" type="checkbox"/> No</p>			
<p>5.24 Is there an accessible route that is stable, firm and slip-resistant? [302.1]</p>	<p><input type="checkbox"/> Yes <input type="checkbox"/> No</p>		
<p>5.25 Is the route at least 36 inches wide? [403.5.1]</p>	<p><input type="checkbox"/> Yes <input type="checkbox"/> No</p>		
<p>5.26 Is the running slope no steeper than 1:20, i.e. for every inch of height change there are at least 20 inches of route run? [403.3] Note: If the running slope is steeper than 1:20, treat as a ramp and add features such as edge protection and handrails.</p>	<p><input type="checkbox"/> Yes <input type="checkbox"/> No Measurement:</p>		

ADA Checklist for Existing Facilities - Parks

<p>5.27 Is the cross slope no steeper than 1:48? [403.3]</p>	<p><input type="checkbox"/> Yes <input type="checkbox"/> No</p> <p>Measurement:</p>	
---	---	--

Benches Yes No

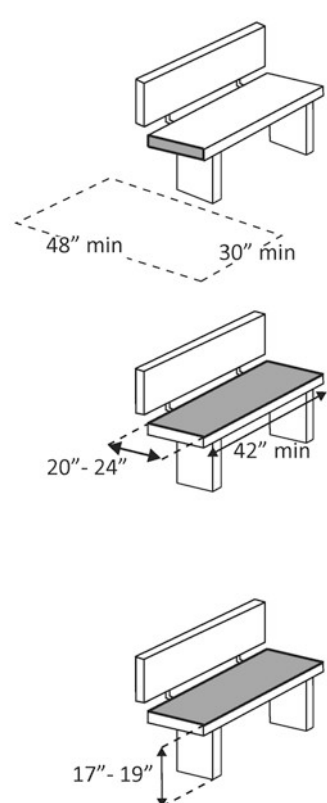
<p>5.28 Is there a clear floor space at least 30 inches wide by at least 48 inches long at the end of the bench and parallel to the short axis of the bench?</p> <p>Is the bench seat at least 42 inches long and no less than 20 inches and no greater than 24 inches deep?</p> <p>Does the bench have back support or is it affixed to a wall?</p> <p>Is the top of the bench seat no less than 17 inches and no greater than 19 inches above the floor? [903]</p>	<p><input type="checkbox"/> Yes <input type="checkbox"/> No</p> <p>Measurement:</p> <p><input type="checkbox"/> Yes <input type="checkbox"/> No</p> <p>Measurement:</p> <p><input type="checkbox"/> Yes <input type="checkbox"/> No</p> <p><input type="checkbox"/> Yes <input type="checkbox"/> No</p> <p>Measurement:</p>	 <p>The diagrams illustrate the ADA requirements for benches. The top diagram shows a side view of a bench with a dashed rectangle indicating a clear floor space of at least 48 inches by 30 inches at the end of the seat. The middle diagram shows a top-down view of the bench seat, with arrows indicating a minimum length of 42 inches and a depth between 20 and 24 inches. The bottom diagram shows a side view of the bench seat height, with a dashed line and arrow indicating a height between 17 and 19 inches above the ground.</p>
---	---	---

Dining Tables Yes No

<p>5.28 Are at least 5 percent, but not less than one, of the dining surfaces for the seating and standing spaces accessible?</p> <p>Is/are the accessible space(s) distributed throughout the facility and located on an accessible route?</p>	<p><input type="checkbox"/> Yes <input checked="" type="checkbox"/> No</p> <p>Total #: Accessible #:</p> <p><input type="checkbox"/> Yes <input checked="" type="checkbox"/> No</p>	
--	---	--

ADA Checklist for Existing Facilities - Parks

City of Grand Rapids ADA Transition Plan

Building: Oakland Park

Location: SE 4th Street

Date: 10/2/19

Evaluated By: Dom DeGuseppi

Priority 5 - Parks

5.1 Is there at least one route from site arrival points (parking, passenger loading zones, public sidewalks and public transportation stops) that does not require the use of stairs? [See 2010 ADA Standards for Accessible Design – 206.2.1]

Yes No

If yes, location of route:

Parking Yes No

5.2 If parking is provided for the public, are an adequate number of accessible spaces provided? [208.2]

Yes No

Total #: **22**
Accessible #: **0**

Total Spaces	Accessible Spaces
1 - 25	1
26 - 50	2
51 - 75	3
76 - 100	4
100+ see 2010 Standards 208.2	



5.3 Are accessible spaces at least 8 feet wide with an access aisle at least 8 feet wide? [502.2, 502.3]

Yes No

Measurement:

Note: Two spaces may share an access aisle. Check state/local requirements;

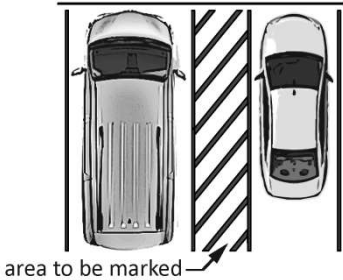
ADA Checklist for Existing Facilities - Parks

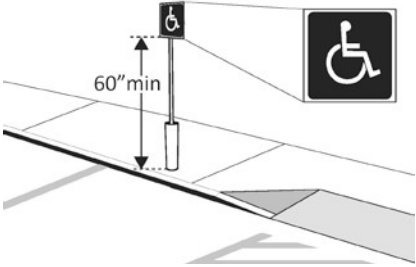
	some specify that each space have its own aisle.			
5.4	<p>Are the access aisles marked with signage and surface painting so as to discourage parking in them? [502.3.3]</p> <p>Note: The marking method and color may be addressed by state/local requirements.</p>	<input type="checkbox"/> Yes <input checked="" type="checkbox"/> No		
5.5	<p>Is the slope of the accessible parking spaces and access aisles no steeper than 1:48 in all directions? [502.4]</p>	<input type="checkbox"/> Yes <input checked="" type="checkbox"/> No Measurement: NA		
5.6	<p>Do the access aisles adjoin an accessible route? [502.3]</p>	<input type="checkbox"/> Yes <input checked="" type="checkbox"/> No		
5.7	<p>Are accessible spaces identified with a sign that includes the International Symbol of Accessibility?</p> <p>Is the bottom of the sign at least 60 inches and not greater than 66 inches above the ground? [502.6]</p>	<input type="checkbox"/> Yes <input checked="" type="checkbox"/> No <input type="checkbox"/> Yes <input checked="" type="checkbox"/> No Measurement:		
5.8	<p>Of the total parking spaces, are the accessible spaces located on the closest accessible route to the accessible entrance(s)? [208.3.1]</p>	<input type="checkbox"/> Yes <input checked="" type="checkbox"/> No		

Exterior Accessible Route

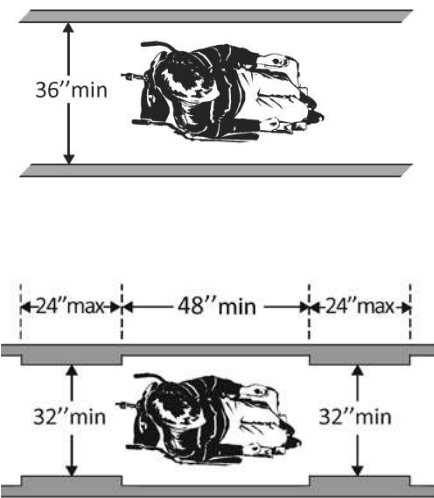
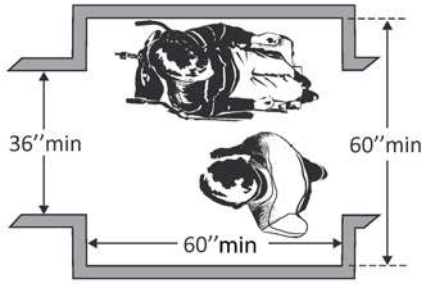
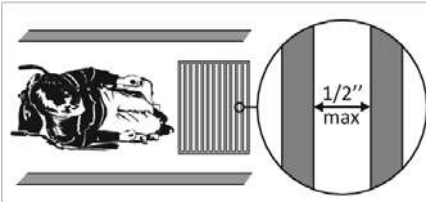
<p>5.9 Is the route stable, firm and slip-resistant? [302.1]</p>	<p><input checked="" type="checkbox"/> Yes <input type="checkbox"/> No</p>	
<p>5.10 Is the route at least 36 inches wide? [403.5.1]</p> <p>Note: The accessible route can narrow to 32 inches min. for a max. of 24 inches. These narrower portions of the route must be at least 48 inches from each other.</p>	<p><input checked="" type="checkbox"/> Yes <input type="checkbox"/> No</p> <p>Measurement: 10'</p>	
<p>5.11 If the route is greater than 200 feet in length and less than 60 inches wide, is there a passing space no less than 60 x 60 inches? [403.5.3]</p>	<p><input type="checkbox"/> Yes <input checked="" type="checkbox"/> No</p> <p>Measurement: NA</p>	
<p>5.12 If there are grates or openings on the route, are the openings no larger than 1/2 inches?</p>	<p>If the route is greater than 200 feet in length and less than 60 inches wide, is there a passing space no less than 60 x 60 inches? [403.5.3]</p>	

ADA Checklist for Existing Facilities - Parks

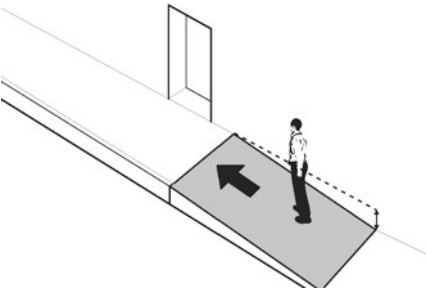
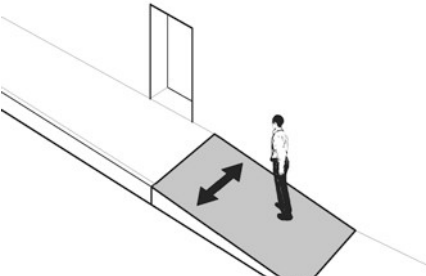
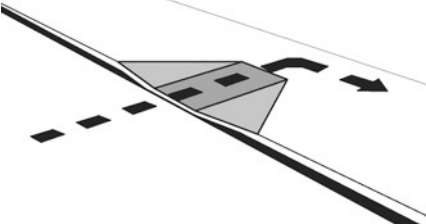
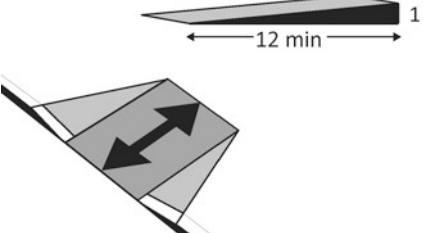
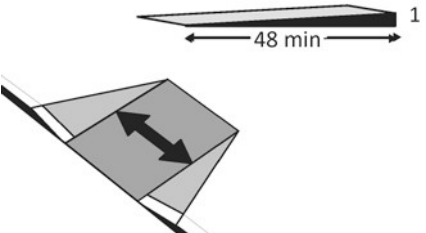
<p>5.13 Is the running slope no steeper than 1:20, i.e. for every inch of height change there are at least 20 inches of route run? [403.3]</p> <p>Note: If the running slope is steeper than 1:20, treat as a ramp and add features such as edge protection and handrails.</p>	<p><input checked="" type="checkbox"/> Yes <input type="checkbox"/> No</p> <p>Measurement: 2.4%</p>		
<p>5.14 Is the cross slope no steeper than 1:48? [403.3]</p>	<p><input checked="" type="checkbox"/> Yes <input type="checkbox"/> No</p> <p>Measurement: 1%</p>		
<p>Curb Ramps <input checked="" type="checkbox"/> Yes <input type="checkbox"/> No</p>			
<p>5.15 If the accessible route crosses a curb, is there a curb ramp? [402.2]</p>	<p><input checked="" type="checkbox"/> Yes <input type="checkbox"/> No</p>		
<p>5.16 Is the running slope of the curb ramp no steeper than 1:12, i.e. for every inch of height change there are at least 12 inches of curb ramp run? [406.1, 405.2]</p>	<p><input checked="" type="checkbox"/> Yes <input type="checkbox"/> No</p> <p>Measurement: 2.2%</p>		
<p>5.17 Is the cross slope of the curb ramp, excluding flares, no steeper than 1:48? [406.1, 405.3]</p>	<p><input checked="" type="checkbox"/> Yes <input type="checkbox"/> No</p> <p>Measurement: .7%</p>		

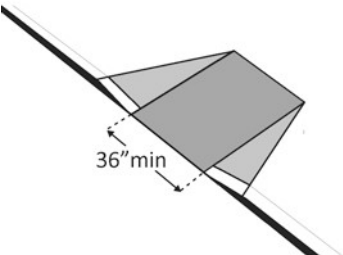
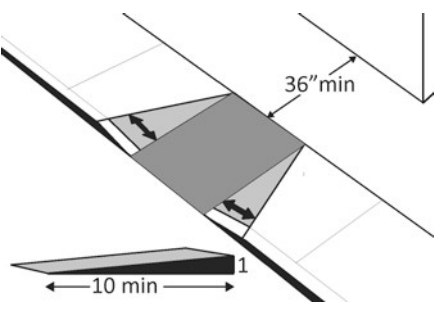
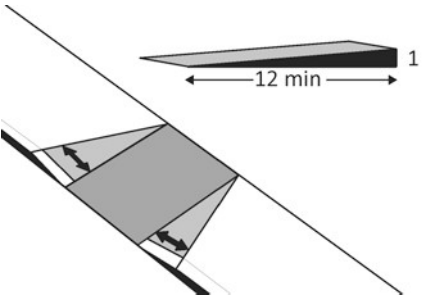
<p>5.18 Is the curb ramp, excluding flares, at least 36 inches wide? [406.1, 405.5]</p>	<p><input checked="" type="checkbox"/> Yes <input type="checkbox"/> No</p> <p>Measurement: 12'</p>		
<p>5.19 At the top of the curb ramp is there a level landing (slope no steeper than 1:48 in all directions) that is at least 36 inches long and at least as wide as the curb ramp? [406.4]</p> <p>If there are curb ramp flares, are the slopes of the flares no steeper than 1:10, i.e. for every inch of height change there are at least 10 inches of flare run? [406.3]</p>	<p><input type="checkbox"/> Yes <input checked="" type="checkbox"/> No</p> <p>Measurement: 2.8%</p> <p><input type="checkbox"/> Yes <input checked="" type="checkbox"/> No</p> <p>Measurement:</p>		
<p>5.20 If the landing at the top is less than 36 inches long, are there curb ramp flares? [406.4]</p> <p>Are the slopes of the flares no greater than 1:12, i.e. for every inch of height change there are at least 12 inches of flare run? [406.4]</p>	<p><input type="checkbox"/> Yes <input checked="" type="checkbox"/> No</p> <p><input type="checkbox"/> Yes <input checked="" type="checkbox"/> No</p> <p>Measurement:</p>		
<p>Accessible Play Components <input checked="" type="checkbox"/> Yes <input type="checkbox"/> No</p>			
<p>5.21 <u>Ground Level Play Components</u> Is there an accessible route to at least one of each type of ground level play component? [406.4]</p> <p>Notes:</p> <ol style="list-style-type: none"> 1. A play component is an element designed to generate play, socialization and learning. 2. Ground level play components are components that can be approached and exited at 	<p><input checked="" type="checkbox"/> Yes <input type="checkbox"/> No</p>		

ADA Checklist for Existing Facilities - Parks

<p>ground level. Examples include rockers, swings, diggers and stand-alone slides.</p>			
<p>5.22 <u>Elevated Play Components</u> Are there any accessible elevated play components?</p> <p>If so, is there an accessible route to the components?</p>	<p><input type="checkbox"/> Yes <input checked="" type="checkbox"/> No</p> <p><input type="checkbox"/> Yes <input checked="" type="checkbox"/> No</p>		
<p>5.23 Is the vertical clearance of the accessible route at least 80 inches above the ground surface?</p> <p>Note: Objects below 80 inches may not protrude into the accessible route.</p>	<p><input checked="" type="checkbox"/> Yes <input type="checkbox"/> No</p>		
<p>Pavilion <input type="checkbox"/> Yes <input checked="" type="checkbox"/> No</p>			
<p>5.24 Is there an accessible route that is stable, firm and slip-resistant? [302.1]</p>	<p><input type="checkbox"/> Yes <input type="checkbox"/> No</p>		
<p>5.25 Is the route at least 36 inches wide? [403.5.1]</p>	<p><input type="checkbox"/> Yes <input type="checkbox"/> No</p>		
<p>5.26 Is the running slope no steeper than 1:20, i.e. for every inch of height change there are at least 20 inches of route run? [403.3]</p> <p>Note: If the running slope is steeper than 1:20, treat as a ramp and add features such as edge protection and handrails.</p>	<p><input type="checkbox"/> Yes <input type="checkbox"/> No</p> <p>Measurement:</p>		

ADA Checklist for Existing Facilities - Parks

<p>5.27 Is the cross slope no steeper than 1:48? [403.3]</p>	<p><input type="checkbox"/> Yes <input type="checkbox"/> No</p> <p>Measurement:</p>	
---	---	--

Benches Yes No

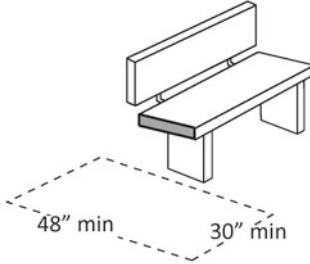
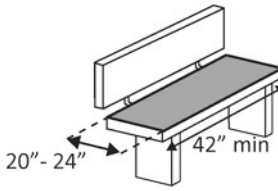
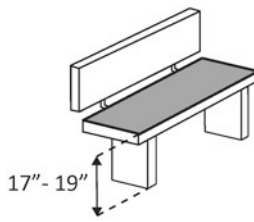
<p>5.28 Is there a clear floor space at least 30 inches wide by at least 48 inches long at the end of the bench and parallel to the short axis of the bench?</p> <p>Is the bench seat at least 42 inches long and no less than 20 inches and no greater than 24 inches deep?</p> <p>Does the bench have back support or is it affixed to a wall?</p> <p>Is the top of the bench seat no less than 17 inches and no greater than 19 inches above the floor? [903]</p>	<p><input checked="" type="checkbox"/> Yes <input type="checkbox"/> No</p> <p>Measurement:</p> <p><input checked="" type="checkbox"/> Yes <input type="checkbox"/> No</p> <p>Measurement:</p> <p>70"</p> <p><input checked="" type="checkbox"/> Yes <input type="checkbox"/> No</p> <p><input checked="" type="checkbox"/> Yes <input type="checkbox"/> No</p> <p>Measurement:</p> <p>18"</p>	<p>Ground</p>   	
---	---	---	--

Dining Tables Yes No

<p>5.28 Are at least 5 percent, but not less than one, of the dining surfaces for the seating and standing spaces accessible?</p> <p>Is/are the accessible space(s) distributed throughout the facility and located on an accessible route?</p>	<p><input checked="" type="checkbox"/> Yes <input type="checkbox"/> No</p> <p>Total #: 2 Accessible #: 1</p> <p><input checked="" type="checkbox"/> Yes <input type="checkbox"/> No</p>	
--	---	--

ADA Checklist for Existing Facilities - Parks

City of Grand Rapids ADA Transition Plan

Building: Pokegama Golf Course

Location: Golf Course Road



Date: 10/2/19

Evaluated By: Dom DeGuseppi

Priority 5 - Parks

5.1	<p>Is there at least one route from site arrival points (parking, passenger loading zones, public sidewalks and public transportation stops) that does not require the use of stairs? [See 2010 ADA Standards for Accessible Design – 206.2.1]</p>	<p><input checked="" type="checkbox"/> Yes <input type="checkbox"/> No</p> <p>If yes, location of route:</p>		Sidewalk from parking lot to building												
<p>Parking <input checked="" type="checkbox"/> Yes <input type="checkbox"/> No</p>																
5.2	<p>If parking is provided for the public, are an adequate number of accessible spaces provided? [208.2]</p>	<p><input checked="" type="checkbox"/> Yes <input type="checkbox"/> No</p> <p>Total #: Accessible #: 5</p>	<table border="1"> <thead> <tr> <th>Total Spaces</th> <th>Accessible Spaces</th> </tr> </thead> <tbody> <tr> <td>1 - 25</td> <td>1</td> </tr> <tr> <td>26 - 50</td> <td>2</td> </tr> <tr> <td>51 - 75</td> <td>3</td> </tr> <tr> <td>76 - 100</td> <td>4</td> </tr> <tr> <td colspan="2">100+ see 2010 Standards 208.2</td> </tr> </tbody> </table>	Total Spaces	Accessible Spaces	1 - 25	1	26 - 50	2	51 - 75	3	76 - 100	4	100+ see 2010 Standards 208.2		
Total Spaces	Accessible Spaces															
1 - 25	1															
26 - 50	2															
51 - 75	3															
76 - 100	4															
100+ see 2010 Standards 208.2																
5.3	<p>Are accessible spaces at least 8 feet wide with an access aisle at least 8 feet wide? [502.2, 502.3]</p> <p>Note: Two spaces may share an access aisle. Check state/local requirements;</p>	<p><input type="checkbox"/> Yes <input checked="" type="checkbox"/> No</p> <p>Measurement: 7.5'</p>		Shape of spaces creates uneven spaces												

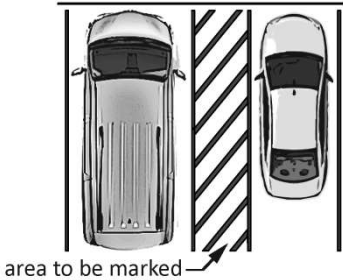
ADA Checklist for Existing Facilities - Parks

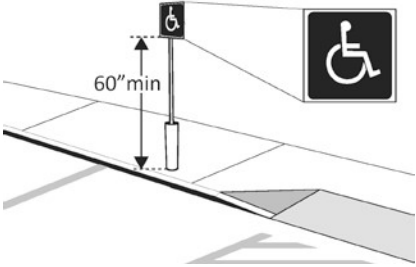
	some specify that each space have its own aisle.			
5.4	<p>Are the access aisles marked with signage and surface painting so as to discourage parking in them? [502.3.3]</p> <p>Note: The marking method and color may be addressed by state/local requirements.</p>	<input checked="" type="checkbox"/> Yes <input type="checkbox"/> No		
5.5	<p>Is the slope of the accessible parking spaces and access aisles no steeper than 1:48 in all directions? [502.4]</p>	<input type="checkbox"/> Yes <input checked="" type="checkbox"/> No Measurement: 2.3		
5.6	<p>Do the access aisles adjoin an accessible route? [502.3]</p>	<input checked="" type="checkbox"/> Yes <input type="checkbox"/> No		
5.7	<p>Are accessible spaces identified with a sign that includes the International Symbol of Accessibility?</p> <p>Is the bottom of the sign at least 60 inches and not greater than 66 inches above the ground? [502.6]</p>	<input checked="" type="checkbox"/> Yes <input type="checkbox"/> No <input type="checkbox"/> Yes <input checked="" type="checkbox"/> No Measurement: 58"-63"		
5.8	<p>Of the total parking spaces, are the accessible spaces located on the closest accessible route to the accessible entrance(s)? [208.3.1]</p>	<input checked="" type="checkbox"/> Yes <input type="checkbox"/> No		

Exterior Accessible Route

5.9 Is the route stable, firm and slip-resistant?
[302.1] Yes No

5.10 Is the route at least 36 inches wide?
[403.5.1] Yes No
Measurement:
10'

Note: The accessible route can narrow to 32 inches min. for a max. of 24 inches. These narrower portions of the route must be at least 48 inches from each other.

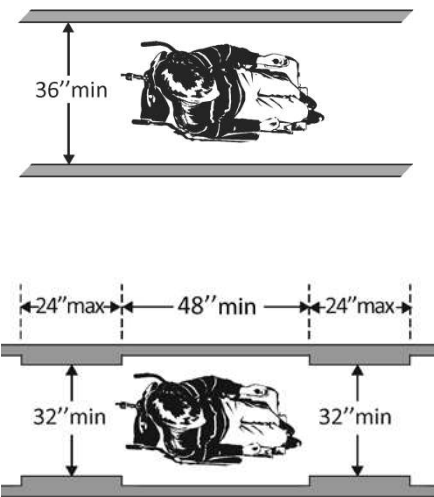

5.11 If the route is greater than 200 feet in length and less than 60 inches wide, is there a passing space no less than 60 x 60 inches?
[403.5.3] Yes No
Measurement:
NA

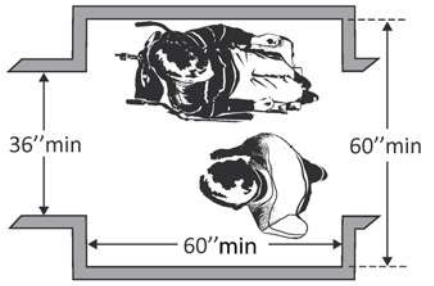

5.12 If there are grates or openings on the route, are the openings no larger than 1/2 inches?
If the route is greater than 200 feet in length and less than 60 inches wide, is there a passing space no less than 60 x 60 inches?
[403.5.3]

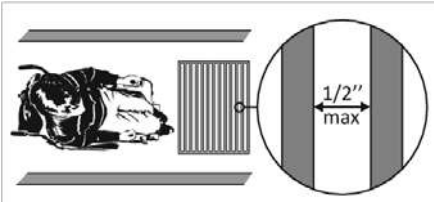

ADA Checklist for Existing Facilities - Parks

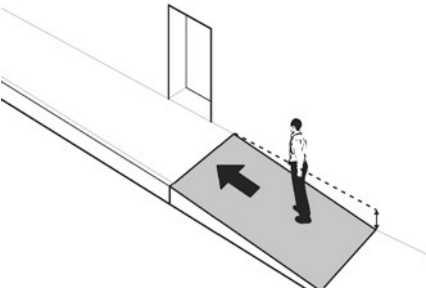
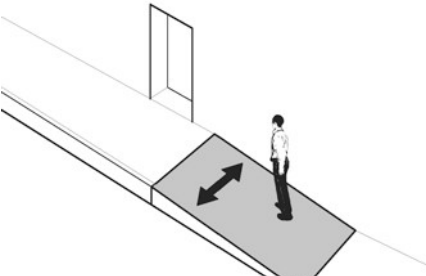
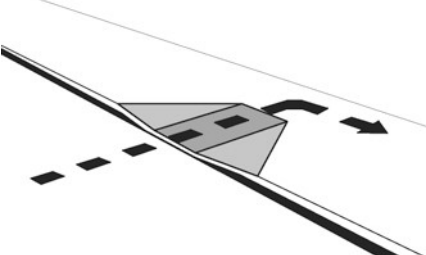
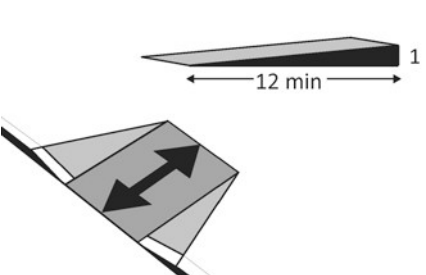
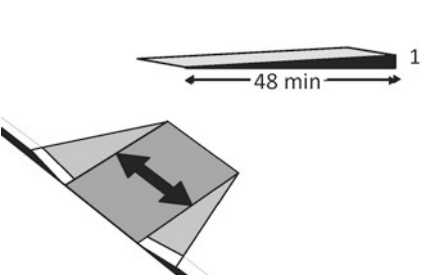
<p>5.13 Is the running slope no steeper than 1:20, i.e. for every inch of height change there are at least 20 inches of route run? [403.3]</p> <p>Note: If the running slope is steeper than 1:20, treat as a ramp and add features such as edge protection and handrails.</p>	<p><input type="checkbox"/> Yes <input checked="" type="checkbox"/> No</p> <p>Measurement: 6.3%</p>		
<p>5.14 Is the cross slope no steeper than 1:48? [403.3]</p>	<p><input type="checkbox"/> Yes <input checked="" type="checkbox"/> No</p> <p>Measurement: 2.4%</p>		
<p>Curb Ramps <input checked="" type="checkbox"/> Yes <input type="checkbox"/> No</p>			
<p>5.15 If the accessible route crosses a curb, is there a curb ramp? [402.2]</p>	<p><input checked="" type="checkbox"/> Yes <input type="checkbox"/> No</p>		
<p>5.16 Is the running slope of the curb ramp no steeper than 1:12, i.e. for every inch of height change there are at least 12 inches of curb ramp run? [406.1, 405.2]</p>	<p><input type="checkbox"/> Yes <input checked="" type="checkbox"/> No</p> <p>Measurement: 5.4%</p>		
<p>5.17 Is the cross slope of the curb ramp, excluding flares, no steeper than 1:48? [406.1, 405.3]</p>	<p><input checked="" type="checkbox"/> Yes <input type="checkbox"/> No</p> <p>Measurement: 1.4%</p>		

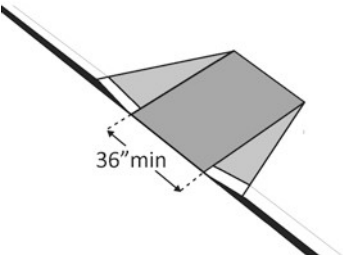
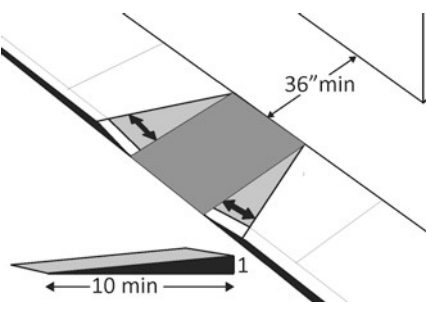
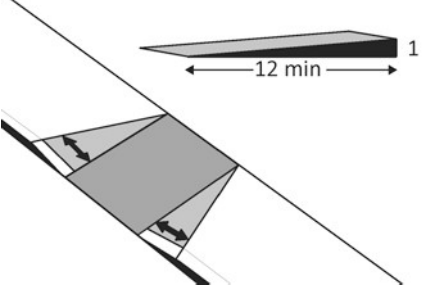
<p>5.18 Is the curb ramp, excluding flares, at least 36 inches wide? [406.1, 405.5]</p>	<p><input checked="" type="checkbox"/> Yes <input type="checkbox"/> No</p> <p>Measurement: 10'</p>		
<p>5.19 At the top of the curb ramp is there a level landing (slope no steeper than 1:48 in all directions) that is at least 36 inches long and at least as wide as the curb ramp? [406.4]</p> <p>If there are curb ramp flares, are the slopes of the flares no steeper than 1:10, i.e. for every inch of height change there are at least 10 inches of flare run? [406.3]</p>	<p><input type="checkbox"/> Yes <input checked="" type="checkbox"/> No</p> <p>Measurement:</p> <p><input type="checkbox"/> Yes <input checked="" type="checkbox"/> No</p> <p>Measurement:</p>		<p>No landing</p>
<p>5.20 If the landing at the top is less than 36 inches long, are there curb ramp flares? [406.4]</p> <p>Are the slopes of the flares no greater than 1:12, i.e. for every inch of height change there are at least 12 inches of flare run? [406.4]</p>	<p><input type="checkbox"/> Yes <input checked="" type="checkbox"/> No</p> <p><input type="checkbox"/> Yes <input checked="" type="checkbox"/> No</p> <p>Measurement:</p>		<p>No landing</p>
<p>Accessible Play Components <input type="checkbox"/> Yes <input checked="" type="checkbox"/> No</p>			
<p>5.21 <u>Ground Level Play Components</u> Is there an accessible route to at least one of each type of ground level play component? [406.4]</p> <p>Notes:</p> <ol style="list-style-type: none"> 1. A play component is an element designed to generate play, socialization and learning. 2. Ground level play components are components that can be approached and exited at 	<p><input type="checkbox"/> Yes <input type="checkbox"/> No</p>		

ADA Checklist for Existing Facilities - Parks

<p>ground level. Examples include rockers, swings, diggers and stand-alone slides.</p>			
<p>5.22 <u>Elevated Play Components</u> Are there any accessible elevated play components? If so, is there an accessible route to the components?</p>	<p><input type="checkbox"/> Yes <input type="checkbox"/> No <input type="checkbox"/> Yes <input type="checkbox"/> No</p>		
<p>5.23 Is the vertical clearance of the accessible route at least 80 inches above the ground surface? Note: Objects below 80 inches may not protrude into the accessible route.</p>	<p><input type="checkbox"/> Yes <input type="checkbox"/> No</p>		
<p>Pavilion <input checked="" type="checkbox"/> Yes <input type="checkbox"/> No</p>			
<p>5.24 Is there an accessible route that is stable, firm and slip-resistant? [302.1]</p>	<p><input checked="" type="checkbox"/> Yes <input type="checkbox"/> No</p>		
<p>5.25 Is the route at least 36 inches wide? [403.5.1]</p>	<p><input checked="" type="checkbox"/> Yes <input type="checkbox"/> No</p>		
<p>5.26 Is the running slope no steeper than 1:20, i.e. for every inch of height change there are at least 20 inches of route run? [403.3] Note: If the running slope is steeper than 1:20, treat as a ramp and add features such as edge protection and handrails.</p>	<p><input type="checkbox"/> Yes <input checked="" type="checkbox"/> No Measurement: 6.3%</p>		

ADA Checklist for Existing Facilities - Parks

<p>5.27 Is the cross slope no steeper than 1:48? [403.3]</p>	<p><input checked="" type="checkbox"/> Yes <input type="checkbox"/> No</p> <p>Measurement: 1.2%</p>	
---	--	--

Benches Yes No

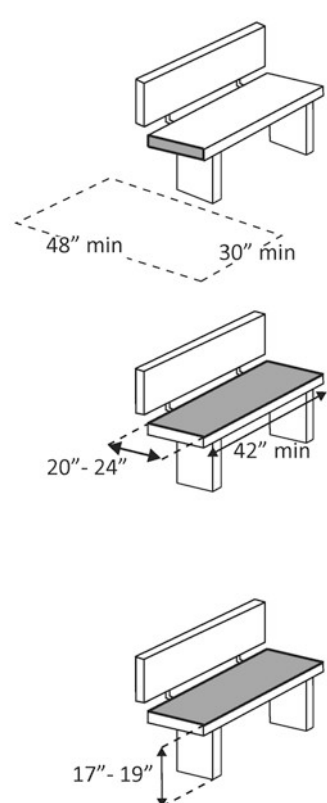
<p>5.28 Is there a clear floor space at least 30 inches wide by at least 48 inches long at the end of the bench and parallel to the short axis of the bench?</p> <p>Is the bench seat at least 42 inches long and no less than 20 inches and no greater than 24 inches deep?</p> <p>Does the bench have back support or is it affixed to a wall?</p> <p>Is the top of the bench seat no less than 17 inches and no greater than 19 inches above the floor? [903]</p>	<p><input type="checkbox"/> Yes <input checked="" type="checkbox"/> No</p> <p>Measurement:</p> <p><input type="checkbox"/> Yes <input checked="" type="checkbox"/> No</p> <p>Measurement:</p> <p><input type="checkbox"/> Yes <input checked="" type="checkbox"/> No</p> <p><input type="checkbox"/> Yes <input checked="" type="checkbox"/> No</p> <p>Measurement:</p>	 <p>The diagrams illustrate the required clearances for a bench. The top diagram shows a top-down view of a bench with a dashed rectangle indicating a clear floor space of at least 48 inches in length and 30 inches in width at the end of the bench. The middle diagram shows a side view of the bench seat, with arrows indicating a minimum length of 42 inches and a depth between 20 and 24 inches. The bottom diagram shows a side view of the bench seat height, with an arrow indicating it must be between 17 and 19 inches above the floor.</p>
---	---	---

Dining Tables Yes No

<p>5.28 Are at least 5 percent, but not less than one, of the dining surfaces for the seating and standing spaces accessible?</p> <p>Is/are the accessible space(s) distributed throughout the facility and located on an accessible route?</p>	<p><input type="checkbox"/> Yes <input checked="" type="checkbox"/> No</p> <p>Total #: 2 Accessible #: 0</p> <p><input type="checkbox"/> Yes <input checked="" type="checkbox"/> No</p>	
--	---	--

ADA Checklist for Existing Facilities - Parks

City of Grand Rapids ADA Transition Plan

Building: River Front Trail

Location: Library

Date: 10/8/19

Evaluated By: Dom DeGuseppi

Priority 5 - Parks

5.1 Is there at least one route from site arrival points (parking, passenger loading zones, public sidewalks and public transportation stops) that does not require the use of stairs? [See 2010 ADA Standards for Accessible Design – 206.2.1]

Yes No

If yes, location of route:

Parking Yes No

5.2 If parking is provided for the public, are an adequate number of accessible spaces provided? [208.2]

Yes No

Total #: **99**
Accessible #: **5**

Total Spaces	Accessible Spaces
1 - 25	1
26 - 50	2
51 - 75	3
76 - 100	4
100+ see 2010 Standards 208.2	

5.3 Are accessible spaces at least 8 feet wide with an access aisle at least 8 feet wide? [502.2, 502.3]



Yes No

Measurement: **5'**

Note: Two spaces may share an access aisle. Check state/local requirements;

One access aisle is not marked and one is less than 8'

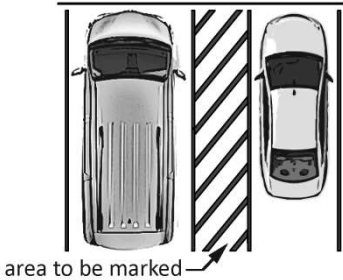
ADA Checklist for Existing Facilities - Parks

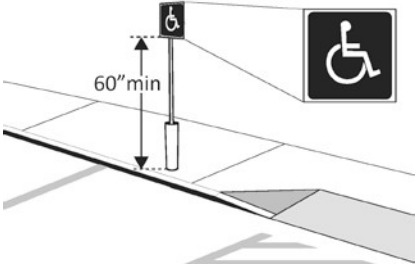
	some specify that each space have its own aisle.			
5.4	<p>Are the access aisles marked with signage and surface painting so as to discourage parking in them? [502.3.3]</p> <p>Note: The marking method and color may be addressed by state/local requirements.</p>	<input checked="" type="checkbox"/> Yes <input type="checkbox"/> No		
5.5	<p>Is the slope of the accessible parking spaces and access aisles no steeper than 1:48 in all directions? [502.4]</p>	<input checked="" type="checkbox"/> Yes <input type="checkbox"/> No Measurement:		
5.6	<p>Do the access aisles adjoin an accessible route? [502.3]</p>	<input checked="" type="checkbox"/> Yes <input type="checkbox"/> No		
5.7	<p>Are accessible spaces identified with a sign that includes the International Symbol of Accessibility? Is the bottom of the sign at least 60 inches and not greater than 66 inches above the ground? [502.6]</p>	<input checked="" type="checkbox"/> Yes <input type="checkbox"/> No <input type="checkbox"/> Yes <input checked="" type="checkbox"/> No Measurement: 84"		One sign is to 84" tall
5.8	<p>Of the total parking spaces, are the accessible spaces located on the closest accessible route to the accessible entrance(s)? [208.3.1]</p>	<input checked="" type="checkbox"/> Yes <input type="checkbox"/> No		

Exterior Accessible Route

<p>5.9 Is the route stable, firm and slip-resistant? [302.1]</p>	<p><input checked="" type="checkbox"/> Yes <input type="checkbox"/> No</p>	
<p>5.10 Is the route at least 36 inches wide? [403.5.1]</p> <p>Note: The accessible route can narrow to 32 inches min. for a max. of 24 inches. These narrower portions of the route must be at least 48 inches from each other.</p>	<p><input checked="" type="checkbox"/> Yes <input type="checkbox"/> No</p> <p>Measurement: 8'</p>	
<p>5.11 If the route is greater than 200 feet in length and less than 60 inches wide, is there a passing space no less than 60 x 60 inches? [403.5.3]</p>	<p><input type="checkbox"/> Yes <input checked="" type="checkbox"/> No</p> <p>Measurement: NA</p>	
<p>5.12 If there are grates or openings on the route, are the openings no larger than 1/2 inches?</p>	<p>If the route is greater than 200 feet in length and less than 60 inches wide, is there a passing space no less than 60 x 60 inches? [403.5.3]</p>	

ADA Checklist for Existing Facilities - Parks

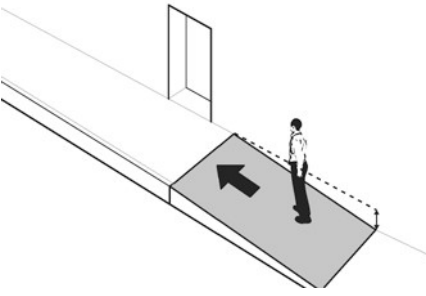
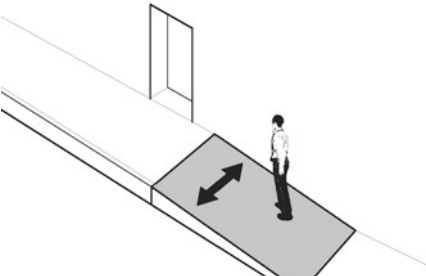
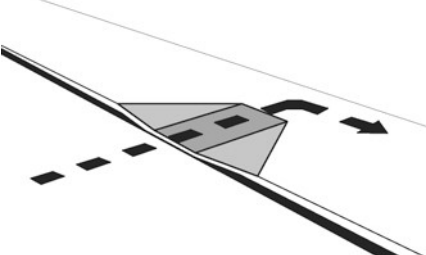
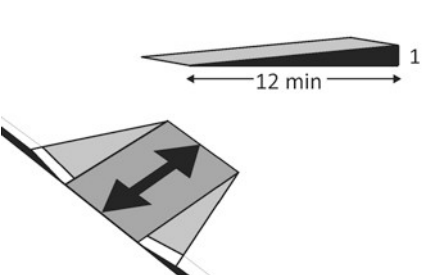
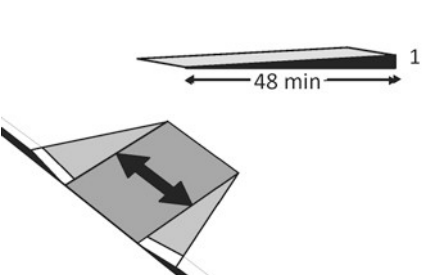
<p>5.13 Is the running slope no steeper than 1:20, i.e. for every inch of height change there are at least 20 inches of route run? [403.3]</p> <p>Note: If the running slope is steeper than 1:20, treat as a ramp and add features such as edge protection and handrails.</p>	<p><input checked="" type="checkbox"/> Yes <input type="checkbox"/> No</p> <p>Measurement: .4%</p>		
<p>5.14 Is the cross slope no steeper than 1:48? [403.3]</p>	<p><input checked="" type="checkbox"/> Yes <input type="checkbox"/> No</p> <p>Measurement: .3%</p>		
<p>Curb Ramps <input type="checkbox"/> Yes <input checked="" type="checkbox"/> No</p>			
<p>5.15 If the accessible route crosses a curb, is there a curb ramp? [402.2]</p>	<p><input type="checkbox"/> Yes <input type="checkbox"/> No</p>		
<p>5.16 Is the running slope of the curb ramp no steeper than 1:12, i.e. for every inch of height change there are at least 12 inches of curb ramp run? [406.1, 405.2]</p>	<p><input type="checkbox"/> Yes <input type="checkbox"/> No</p> <p>Measurement:</p>		
<p>5.17 Is the cross slope of the curb ramp, excluding flares, no steeper than 1:48? [406.1, 405.3]</p>	<p><input type="checkbox"/> Yes <input type="checkbox"/> No</p> <p>Measurement:</p>		

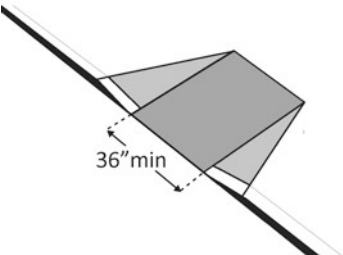
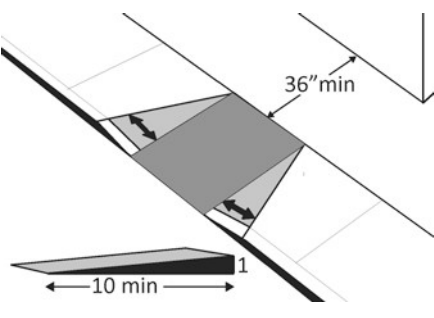
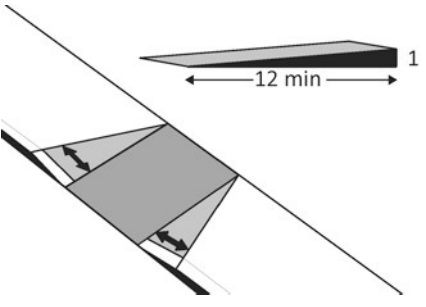
<p>5.18 Is the curb ramp, excluding flares, at least 36 inches wide? [406.1, 405.5]</p>	<p><input type="checkbox"/> Yes <input type="checkbox"/> No</p> <p>Measurement:</p>		
<p>5.19 At the top of the curb ramp is there a level landing (slope no steeper than 1:48 in all directions) that is at least 36 inches long and at least as wide as the curb ramp? [406.4]</p> <p>If there are curb ramp flares, are the slopes of the flares no steeper than 1:10, i.e. for every inch of height change there are at least 10 inches of flare run? [406.3]</p>	<p><input type="checkbox"/> Yes <input type="checkbox"/> No</p> <p>Measurement:</p> <p><input type="checkbox"/> Yes <input type="checkbox"/> No</p> <p>Measurement:</p>		
<p>5.20 If the landing at the top is less than 36 inches long, are there curb ramp flares? [406.4]</p> <p>Are the slopes of the flares no greater than 1:12, i.e. for every inch of height change there are at least 12 inches of flare run? [406.4]</p>	<p><input type="checkbox"/> Yes <input type="checkbox"/> No</p> <p><input type="checkbox"/> Yes <input type="checkbox"/> No</p> <p>Measurement:</p>		
<p>Accessible Play Components <input type="checkbox"/> Yes <input checked="" type="checkbox"/> No</p>			
<p>5.21 <u>Ground Level Play Components</u> Is there an accessible route to at least one of each type of ground level play component?</p> <p>Notes:</p> <ol style="list-style-type: none"> 1. A play component is an element designed to generate play, socialization and learning. 2. Ground level play components are components that can be approached and exited at 	<p><input type="checkbox"/> Yes <input type="checkbox"/> No</p>		

ADA Checklist for Existing Facilities - Parks

<p>ground level. Examples include rockers, swings, diggers and stand-alone slides.</p>			
<p>5.22 <u>Elevated Play Components</u> Are there any accessible elevated play components? If so, is there an accessible route to the components?</p>	<p><input type="checkbox"/> Yes <input type="checkbox"/> No <input type="checkbox"/> Yes <input type="checkbox"/> No</p>		
<p>5.23 Is the vertical clearance of the accessible route at least 80 inches above the ground surface? Note: Objects below 80 inches may not protrude into the accessible route.</p>	<p><input type="checkbox"/> Yes <input type="checkbox"/> No</p>		
<p>Pavilion <input type="checkbox"/> Yes <input checked="" type="checkbox"/> No</p>			
<p>5.24 Is there an accessible route that is stable, firm and slip-resistant? [302.1]</p>	<p><input type="checkbox"/> Yes <input type="checkbox"/> No</p>		
<p>5.25 Is the route at least 36 inches wide? [403.5.1]</p>	<p><input type="checkbox"/> Yes <input type="checkbox"/> No</p>		
<p>5.26 Is the running slope no steeper than 1:20, i.e. for every inch of height change there are at least 20 inches of route run? [403.3] Note: If the running slope is steeper than 1:20, treat as a ramp and add features such as edge protection and handrails.</p>	<p><input type="checkbox"/> Yes <input type="checkbox"/> No Measurement:</p>		

ADA Checklist for Existing Facilities - Parks

<p>5.27 Is the cross slope no steeper than 1:48? [403.3]</p>	<p><input type="checkbox"/> Yes <input type="checkbox"/> No</p> <p>Measurement:</p>	
---	---	--

Benches Yes No

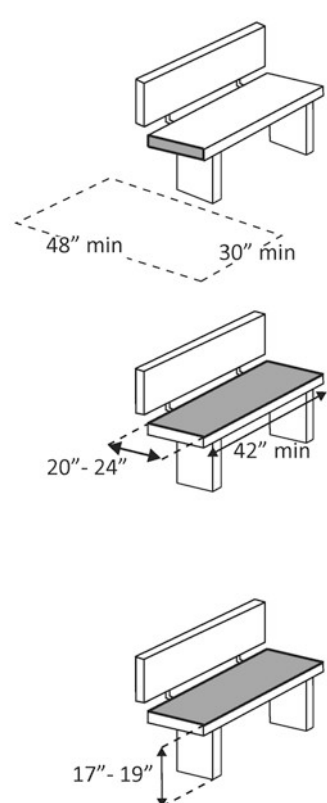
<p>5.28 Is there a clear floor space at least 30 inches wide by at least 48 inches long at the end of the bench and parallel to the short axis of the bench?</p> <p>Is the bench seat at least 42 inches long and no less than 20 inches and no greater than 24 inches deep?</p> <p>Does the bench have back support or is it affixed to a wall?</p> <p>Is the top of the bench seat no less than 17 inches and no greater than 19 inches above the floor? [903]</p>	<p><input checked="" type="checkbox"/> Yes <input type="checkbox"/> No</p> <p>Measurement: 72"</p> <p><input checked="" type="checkbox"/> Yes <input type="checkbox"/> No</p> <p>Measurement: 70"</p> <p><input checked="" type="checkbox"/> Yes <input type="checkbox"/> No</p> <p><input checked="" type="checkbox"/> Yes <input type="checkbox"/> No</p> <p>Measurement: 17"</p>	
---	--	---

Dining Tables Yes No

<p>5.28 Are at least 5 percent, but not less than one, of the dining surfaces for the seating and standing spaces accessible?</p> <p>Is/are the accessible space(s) distributed throughout the facility and located on an accessible route?</p>	<p><input checked="" type="checkbox"/> Yes <input type="checkbox"/> No</p> <p>Total #: 3 Accessible #: 1</p> <p><input checked="" type="checkbox"/> Yes <input type="checkbox"/> No</p>	
--	---	--

ADA Checklist for Existing Facilities - Parks

City of Grand Rapids ADA Transition Plan

Building: Skogebo Park

Location: SW 1st Street

Date: 10/1/19

Evaluated By: Dom DeGuseppi

Priority 5 - Parks

5.1 Is there at least one route from site arrival points (parking, passenger loading zones, public sidewalks and public transportation stops) that does not require the use of stairs?
[See 2010 ADA Standards for Accessible Design – 206.2.1]

Yes No

If yes, location of route:

Parking Yes No

5.2 If parking is provided for the public, are an adequate number of accessible spaces provided? [208.2]	<input type="checkbox"/> Yes <input type="checkbox"/> No Total #: Accessible #:	Total Spaces	Accessible Spaces	No lot/street parking only
		1 - 25	1	
		26 - 50	2	
		51 - 75	3	
		76 - 100	4	
		100+ see 2010 Standards 208.2		



5.3 Are accessible spaces at least 8 feet wide with an access aisle at least 8 feet wide?
[502.2, 502.3]

Yes No

Measurement:

Note: Two spaces may share an access aisle. Check state/local requirements;

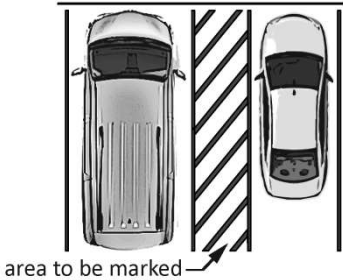
ADA Checklist for Existing Facilities - Parks

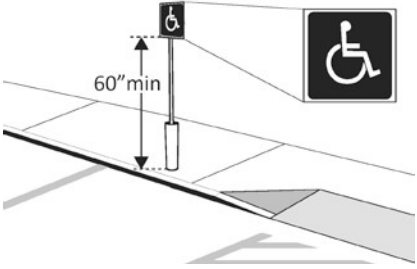
	some specify that each space have its own aisle.		
<p>5.4 Are the access aisles marked with signage and surface painting so as to discourage parking in them? [502.3.3]</p> <p>Note: The marking method and color may be addressed by state/local requirements.</p>	<p><input type="checkbox"/> Yes <input type="checkbox"/> No</p>		
<p>5.5 Is the slope of the accessible parking spaces and access aisles no steeper than 1:48 in all directions? [502.4]</p>	<p><input type="checkbox"/> Yes <input type="checkbox"/> No</p> <p>Measurement:</p>		
<p>5.6 Do the access aisles adjoin an accessible route? [502.3]</p>	<p><input type="checkbox"/> Yes <input type="checkbox"/> No</p>		
<p>5.7 Are accessible spaces identified with a sign that includes the International Symbol of Accessibility?</p> <p>Is the bottom of the sign at least 60 inches and not greater than 66 inches above the ground? [502.6]</p>	<p><input type="checkbox"/> Yes <input type="checkbox"/> No</p> <p><input type="checkbox"/> Yes <input type="checkbox"/> No</p> <p>Measurement:</p>		
<p>5.8 Of the total parking spaces, are the accessible spaces located on the closest accessible route to the accessible entrance(s)? [208.3.1]</p>	<p><input type="checkbox"/> Yes <input type="checkbox"/> No</p>		

Exterior Accessible Route

5.9 Is the route stable, firm and slip-resistant?
[302.1] Yes No

5.10 Is the route at least 36 inches wide?
[403.5.1] Yes No

Measurement:

Note: The accessible route can narrow to 32 inches min. for a max. of 24 inches. These narrower portions of the route must be at least 48 inches from each other.

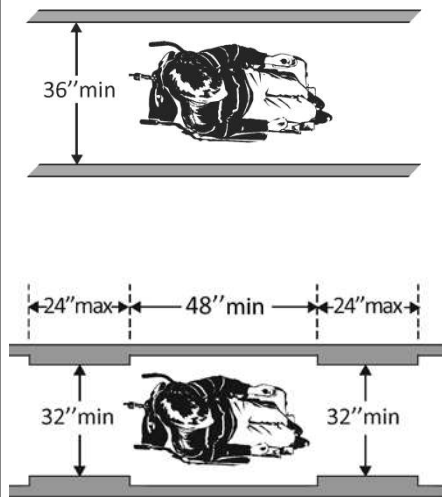

5.11 If the route is greater than 200 feet in length and less than 60 inches wide, is there a passing space no less than 60 x 60 inches?
[403.5.3] Yes No

Measurement:

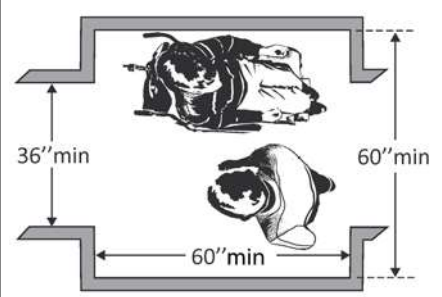

5.12 If there are grates or openings on the route, are the openings no larger than 1/2 inches?
[403.5.3]

If the route is greater than 200 feet in length and less than 60 inches wide, is there a passing space no less than 60 x 60 inches?
[403.5.3]

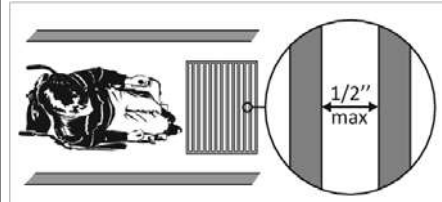

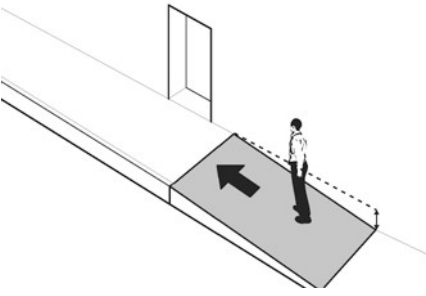
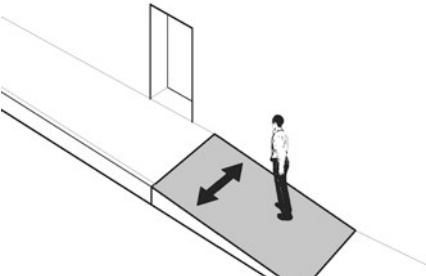
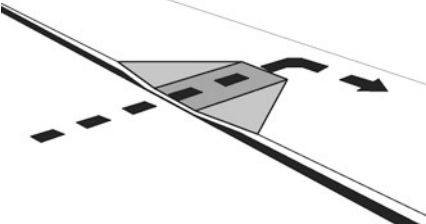
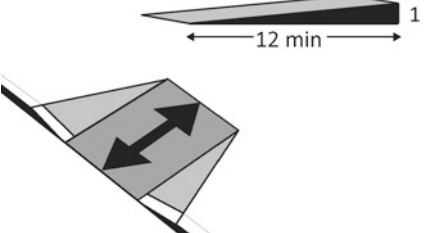
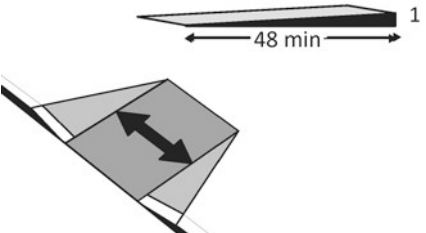
<p>5.13 Is the running slope no steeper than 1:20, i.e. for every inch of height change there are at least 20 inches of route run? [403.3]</p> <p>Note: If the running slope is steeper than 1:20, treat as a ramp and add features such as edge protection and handrails.</p>	<p><input type="checkbox"/> Yes <input type="checkbox"/> No</p> <p>Measurement:</p>		
<p>5.14 Is the cross slope no steeper than 1:48? [403.3]</p>	<p><input type="checkbox"/> Yes <input type="checkbox"/> No</p> <p>Measurement:</p>		
<p>Curb Ramps <input type="checkbox"/> Yes <input checked="" type="checkbox"/> No</p>			
<p>5.15 If the accessible route crosses a curb, is there a curb ramp? [402.2]</p>	<p><input type="checkbox"/> Yes <input type="checkbox"/> No</p>		
<p>5.16 Is the running slope of the curb ramp no steeper than 1:12, i.e. for every inch of height change there are at least 12 inches of curb ramp run? [406.1, 405.2]</p>	<p><input type="checkbox"/> Yes <input type="checkbox"/> No</p> <p>Measurement:</p>		
<p>5.17 Is the cross slope of the curb ramp, excluding flares, no steeper than 1:48? [406.1, 405.3]</p>	<p><input type="checkbox"/> Yes <input type="checkbox"/> No</p> <p>Measurement:</p>		

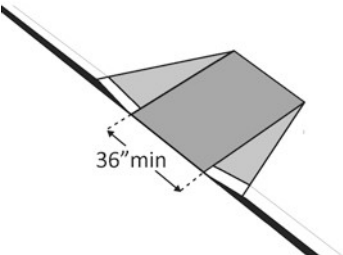
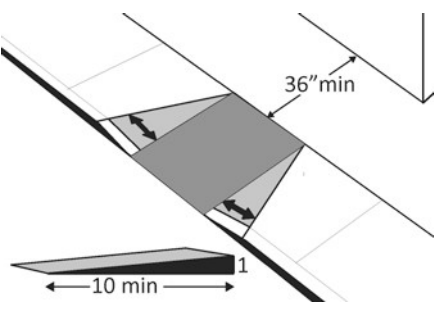
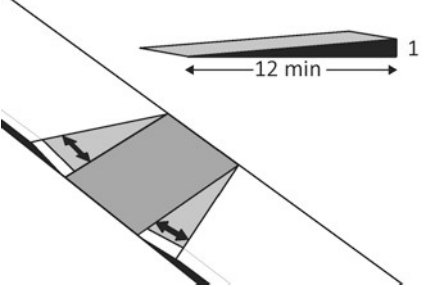
<p>5.18 Is the curb ramp, excluding flares, at least 36 inches wide? [406.1, 405.5]</p>	<p><input type="checkbox"/> Yes <input type="checkbox"/> No</p> <p>Measurement:</p>		
<p>5.19 At the top of the curb ramp is there a level landing (slope no steeper than 1:48 in all directions) that is at least 36 inches long and at least as wide as the curb ramp? [406.4]</p> <p>If there are curb ramp flares, are the slopes of the flares no steeper than 1:10, i.e. for every inch of height change there are at least 10 inches of flare run? [406.3]</p>	<p><input type="checkbox"/> Yes <input type="checkbox"/> No</p> <p>Measurement:</p> <p><input type="checkbox"/> Yes <input type="checkbox"/> No</p> <p>Measurement:</p>		
<p>5.20 If the landing at the top is less than 36 inches long, are there curb ramp flares? [406.4]</p> <p>Are the slopes of the flares no greater than 1:12, i.e. for every inch of height change there are at least 12 inches of flare run? [406.4]</p>	<p><input type="checkbox"/> Yes <input type="checkbox"/> No</p> <p><input type="checkbox"/> Yes <input type="checkbox"/> No</p> <p>Measurement:</p>		
<p>Accessible Play Components <input type="checkbox"/> Yes <input checked="" type="checkbox"/> No</p>			
<p>5.21 <u>Ground Level Play Components</u> Is there an accessible route to at least one of each type of ground level play component?</p> <p>Notes:</p> <ol style="list-style-type: none"> 1. A play component is an element designed to generate play, socialization and learning. 2. Ground level play components are components that can be approached and exited at 	<p><input type="checkbox"/> Yes <input type="checkbox"/> No</p>		

ADA Checklist for Existing Facilities - Parks

<p>ground level. Examples include rockers, swings, diggers and stand-alone slides.</p>			
<p>5.22 <u>Elevated Play Components</u> Are there any accessible elevated play components? If so, is there an accessible route to the components?</p>	<p><input type="checkbox"/> Yes <input type="checkbox"/> No <input type="checkbox"/> Yes <input type="checkbox"/> No</p>		
<p>5.23 Is the vertical clearance of the accessible route at least 80 inches above the ground surface? Note: Objects below 80 inches may not protrude into the accessible route.</p>	<p><input type="checkbox"/> Yes <input type="checkbox"/> No</p>		
<p>Pavilion <input type="checkbox"/> Yes <input checked="" type="checkbox"/> No</p>			
<p>5.24 Is there an accessible route that is stable, firm and slip-resistant? [302.1]</p>	<p><input type="checkbox"/> Yes <input type="checkbox"/> No</p>		
<p>5.25 Is the route at least 36 inches wide? [403.5.1]</p>	<p><input type="checkbox"/> Yes <input type="checkbox"/> No</p>		
<p>5.26 Is the running slope no steeper than 1:20, i.e. for every inch of height change there are at least 20 inches of route run? [403.3] Note: If the running slope is steeper than 1:20, treat as a ramp and add features such as edge protection and handrails.</p>	<p><input type="checkbox"/> Yes <input type="checkbox"/> No Measurement:</p>		

ADA Checklist for Existing Facilities - Parks

<p>5.27 Is the cross slope no steeper than 1:48? [403.3]</p>	<p><input type="checkbox"/> Yes <input type="checkbox"/> No</p> <p>Measurement:</p>	
---	---	--

Benches Yes No

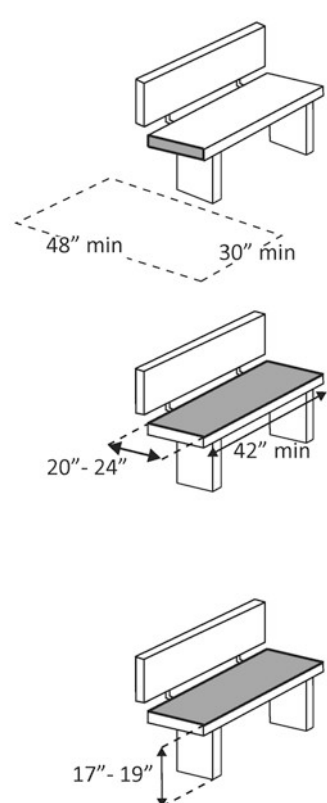
<p>5.28 Is there a clear floor space at least 30 inches wide by at least 48 inches long at the end of the bench and parallel to the short axis of the bench?</p> <p>Is the bench seat at least 42 inches long and no less than 20 inches and no greater than 24 inches deep?</p> <p>Does the bench have back support or is it affixed to a wall?</p> <p>Is the top of the bench seat no less than 17 inches and no greater than 19 inches above the floor? [903]</p>	<p><input type="checkbox"/> Yes <input type="checkbox"/> No</p> <p>Measurement:</p> <p><input type="checkbox"/> Yes <input type="checkbox"/> No</p> <p>Measurement:</p> <p><input type="checkbox"/> Yes <input type="checkbox"/> No</p> <p><input type="checkbox"/> Yes <input type="checkbox"/> No</p> <p>Measurement:</p>	 <p>The diagrams illustrate the required clearances for a bench. The first diagram shows a top-down view of the bench end with a dashed rectangle indicating a minimum clear floor space of 48 inches by 30 inches. The second diagram shows a side view of the bench seat with arrows indicating a minimum length of 42 inches and a depth between 20 inches and 24 inches. The third diagram shows a side view of the bench seat with an arrow indicating a height between 17 inches and 19 inches above the floor.</p>
---	---	--

Dining Tables Yes No

<p>5.28 Are at least 5 percent, but not less than one, of the dining surfaces for the seating and standing spaces accessible?</p> <p>Is/are the accessible space(s) distributed throughout the facility and located on an accessible route?</p>	<p><input type="checkbox"/> Yes <input type="checkbox"/> No</p> <p>Total #: Accessible #:</p> <p><input type="checkbox"/> Yes <input type="checkbox"/> No</p>	
--	---	--

ADA Checklist for Existing Facilities - Parks

City of Grand Rapids ADA Transition Plan

Building: Sports Complex

Location:

Date: 10/10/19

Evaluated By: Dom DeGuseppi

Priority 5 - Parks



5.1	<p>Is there at least one route from site arrival points (parking, passenger loading zones, public sidewalks and public transportation stops) that does not require the use of stairs? [See 2010 ADA Standards for Accessible Design – 206.2.1]</p>	<p><input checked="" type="checkbox"/> Yes <input type="checkbox"/> No</p> <p>If yes, location of route:</p>		Under construction
-----	--	--	--	--------------------

Parking Yes No

5.2	<p>If parking is provided for the public, are an adequate number of accessible spaces provided? [208.2]</p>	<p><input type="checkbox"/> Yes <input type="checkbox"/> No</p> <p>Total #: Accessible #:</p>	<table border="1"> <thead> <tr> <th>Total Spaces</th> <th>Accessible Spaces</th> </tr> </thead> <tbody> <tr> <td>1 - 25</td> <td>1</td> </tr> <tr> <td>26 - 50</td> <td>2</td> </tr> <tr> <td>51 - 75</td> <td>3</td> </tr> <tr> <td>76 - 100</td> <td>4</td> </tr> <tr> <td colspan="2">100+ see 2010 Standards 208.2</td> </tr> </tbody> </table>	Total Spaces	Accessible Spaces	1 - 25	1	26 - 50	2	51 - 75	3	76 - 100	4	100+ see 2010 Standards 208.2		
Total Spaces	Accessible Spaces															
1 - 25	1															
26 - 50	2															
51 - 75	3															
76 - 100	4															
100+ see 2010 Standards 208.2																

5.3	<p>Are accessible spaces at least 8 feet wide with an access aisle at least 8 feet wide? [502.2, 502.3]</p> <p>Note: Two spaces may share an access aisle. Check state/local requirements;</p>	<p><input type="checkbox"/> Yes <input type="checkbox"/> No</p> <p>Measurement:</p>		
-----	--	---	--	--

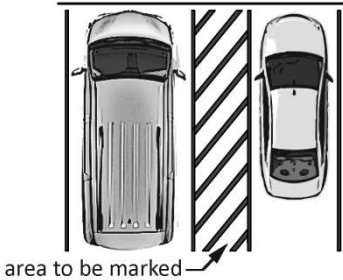
ADA Checklist for Existing Facilities - Parks

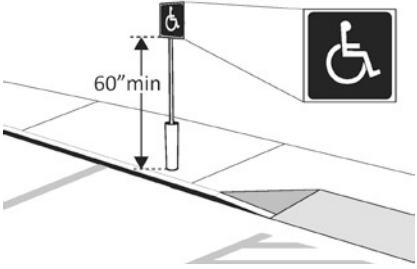
	some specify that each space have its own aisle.		
<p>5.4 Are the access aisles marked with signage and surface painting so as to discourage parking in them? [502.3.3]</p> <p>Note: The marking method and color may be addressed by state/local requirements.</p>	<p><input type="checkbox"/> Yes <input type="checkbox"/> No</p>		
<p>5.5 Is the slope of the accessible parking spaces and access aisles no steeper than 1:48 in all directions? [502.4]</p>	<p><input type="checkbox"/> Yes <input type="checkbox"/> No</p> <p>Measurement:</p>		
<p>5.6 Do the access aisles adjoin an accessible route? [502.3]</p>	<p><input type="checkbox"/> Yes <input type="checkbox"/> No</p>		
<p>5.7 Are accessible spaces identified with a sign that includes the International Symbol of Accessibility?</p> <p>Is the bottom of the sign at least 60 inches and not greater than 66 inches above the ground? [502.6]</p>	<p><input type="checkbox"/> Yes <input type="checkbox"/> No</p> <p><input type="checkbox"/> Yes <input type="checkbox"/> No</p> <p>Measurement:</p>		
<p>5.8 Of the total parking spaces, are the accessible spaces located on the closest accessible route to the accessible entrance(s)? [208.3.1]</p>	<p><input type="checkbox"/> Yes <input type="checkbox"/> No</p>		

Exterior Accessible Route

5.9 Is the route stable, firm and slip-resistant?
[302.1] Yes No

5.10 Is the route at least 36 inches wide?
[403.5.1] Yes No

Measurement:

Note: The accessible route can narrow to 32 inches min. for a max. of 24 inches. These narrower portions of the route must be at least 48 inches from each other.

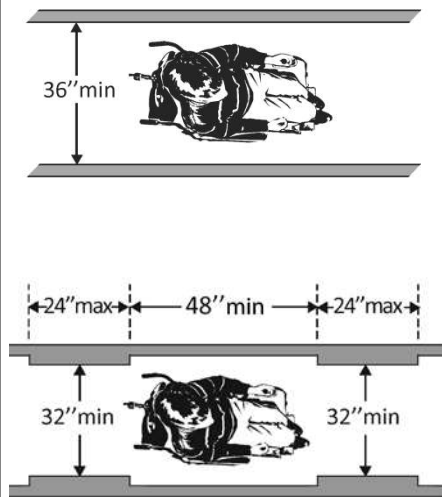

5.11 If the route is greater than 200 feet in length and less than 60 inches wide, is there a passing space no less than 60 x 60 inches?
[403.5.3] Yes No

Measurement:

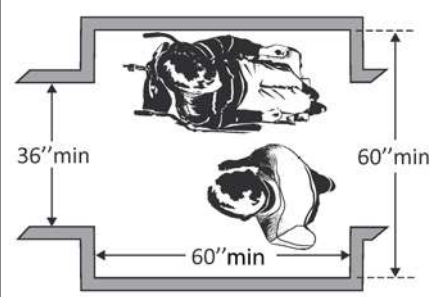

5.12 If there are grates or openings on the route, are the openings no larger than 1/2 inches?
[403.5.3]

If the route is greater than 200 feet in length and less than 60 inches wide, is there a passing space no less than 60 x 60 inches?
[403.5.3]

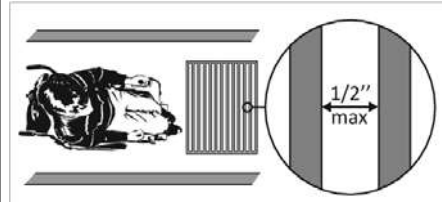

ADA Checklist for Existing Facilities - Parks

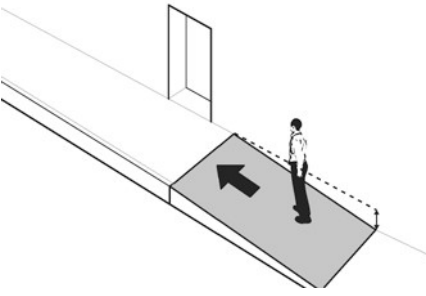
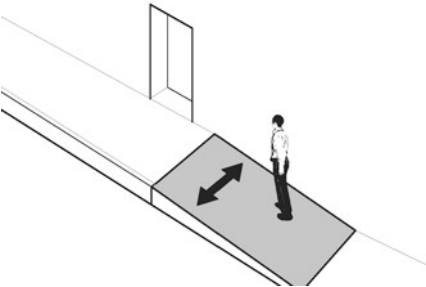
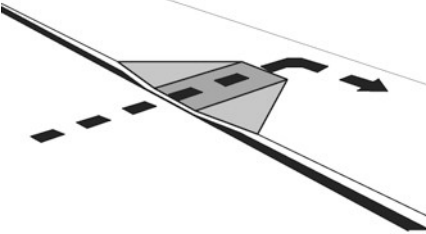
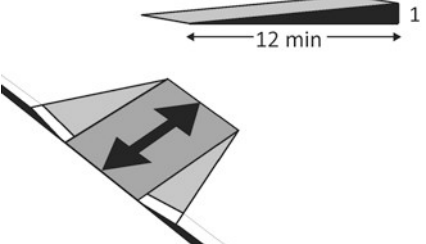
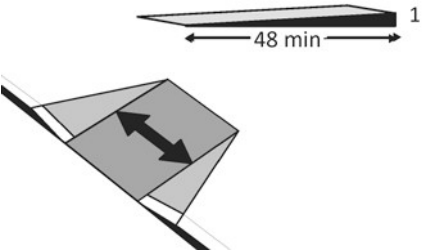
<p>5.13 Is the running slope no steeper than 1:20, i.e. for every inch of height change there are at least 20 inches of route run? [403.3]</p> <p>Note: If the running slope is steeper than 1:20, treat as a ramp and add features such as edge protection and handrails.</p>	<p><input type="checkbox"/> Yes <input type="checkbox"/> No</p> <p>Measurement:</p>		
<p>5.14 Is the cross slope no steeper than 1:48? [403.3]</p>	<p><input type="checkbox"/> Yes <input type="checkbox"/> No</p> <p>Measurement:</p>		
<p>Curb Ramps <input type="checkbox"/> Yes <input type="checkbox"/> No</p>			
<p>5.15 If the accessible route crosses a curb, is there a curb ramp? [402.2]</p>	<p><input type="checkbox"/> Yes <input type="checkbox"/> No</p>		
<p>5.16 Is the running slope of the curb ramp no steeper than 1:12, i.e. for every inch of height change there are at least 12 inches of curb ramp run? [406.1, 405.2]</p>	<p><input type="checkbox"/> Yes <input type="checkbox"/> No</p> <p>Measurement:</p>		
<p>5.17 Is the cross slope of the curb ramp, excluding flares, no steeper than 1:48? [406.1, 405.3]</p>	<p><input type="checkbox"/> Yes <input type="checkbox"/> No</p> <p>Measurement:</p>		

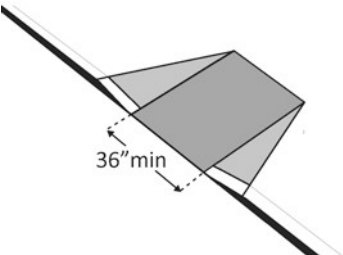
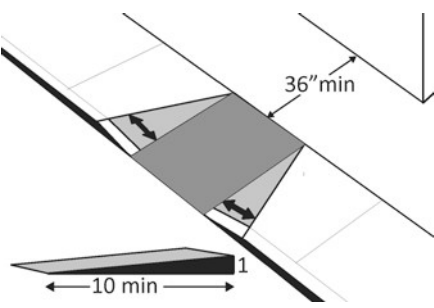
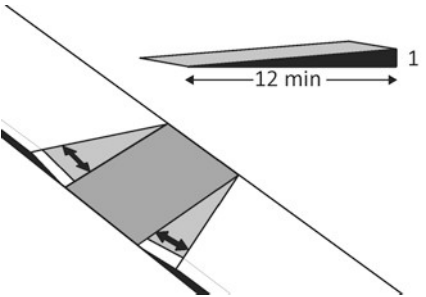
<p>5.18 Is the curb ramp, excluding flares, at least 36 inches wide? [406.1, 405.5]</p>	<p><input type="checkbox"/> Yes <input type="checkbox"/> No</p> <p>Measurement:</p>		
<p>5.19 At the top of the curb ramp is there a level landing (slope no steeper than 1:48 in all directions) that is at least 36 inches long and at least as wide as the curb ramp? [406.4]</p> <p>If there are curb ramp flares, are the slopes of the flares no steeper than 1:10, i.e. for every inch of height change there are at least 10 inches of flare run? [406.3]</p>	<p><input type="checkbox"/> Yes <input type="checkbox"/> No</p> <p>Measurement:</p> <p><input type="checkbox"/> Yes <input type="checkbox"/> No</p> <p>Measurement:</p>		
<p>5.20 If the landing at the top is less than 36 inches long, are there curb ramp flares? [406.4]</p> <p>Are the slopes of the flares no greater than 1:12, i.e. for every inch of height change there are at least 12 inches of flare run? [406.4]</p>	<p><input type="checkbox"/> Yes <input type="checkbox"/> No</p> <p><input type="checkbox"/> Yes <input type="checkbox"/> No</p> <p>Measurement:</p>		
<p>Accessible Play Components <input type="checkbox"/> Yes <input type="checkbox"/> No</p>			
<p>5.21 <u>Ground Level Play Components</u> Is there an accessible route to at least one of each type of ground level play component?</p> <p>Notes:</p> <ol style="list-style-type: none"> 1. A play component is an element designed to generate play, socialization and learning. 2. Ground level play components are components that can be approached and exited at 	<p><input type="checkbox"/> Yes <input type="checkbox"/> No</p>		

ADA Checklist for Existing Facilities - Parks

<p>ground level. Examples include rockers, swings, diggers and stand-alone slides.</p>			
<p>5.22 <u>Elevated Play Components</u> Are there any accessible elevated play components? If so, is there an accessible route to the components?</p>	<p><input type="checkbox"/> Yes <input type="checkbox"/> No <input type="checkbox"/> Yes <input type="checkbox"/> No</p>		
<p>5.23 Is the vertical clearance of the accessible route at least 80 inches above the ground surface? Note: Objects below 80 inches may not protrude into the accessible route.</p>	<p><input type="checkbox"/> Yes <input type="checkbox"/> No</p>		
<p>Pavilion <input type="checkbox"/> Yes <input type="checkbox"/> No</p>			
<p>5.24 Is there an accessible route that is stable, firm and slip-resistant? [302.1]</p>	<p><input type="checkbox"/> Yes <input type="checkbox"/> No</p>		
<p>5.25 Is the route at least 36 inches wide? [403.5.1]</p>	<p><input type="checkbox"/> Yes <input type="checkbox"/> No</p>		
<p>5.26 Is the running slope no steeper than 1:20, i.e. for every inch of height change there are at least 20 inches of route run? [403.3] Note: If the running slope is steeper than 1:20, treat as a ramp and add features such as edge protection and handrails.</p>	<p><input type="checkbox"/> Yes <input type="checkbox"/> No Measurement:</p>		

ADA Checklist for Existing Facilities - Parks

<p>5.27 Is the cross slope no steeper than 1:48? [403.3]</p>	<p><input type="checkbox"/> Yes <input type="checkbox"/> No</p> <p>Measurement:</p>	
---	---	--

Benches Yes No

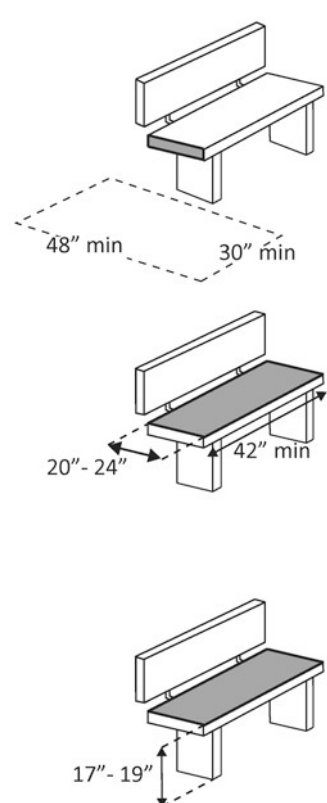
<p>5.28 Is there a clear floor space at least 30 inches wide by at least 48 inches long at the end of the bench and parallel to the short axis of the bench?</p> <p>Is the bench seat at least 42 inches long and no less than 20 inches and no greater than 24 inches deep?</p> <p>Does the bench have back support or is it affixed to a wall?</p> <p>Is the top of the bench seat no less than 17 inches and no greater than 19 inches above the floor? [903]</p>	<p><input type="checkbox"/> Yes <input type="checkbox"/> No</p> <p>Measurement:</p> <p><input type="checkbox"/> Yes <input type="checkbox"/> No</p> <p>Measurement:</p> <p><input type="checkbox"/> Yes <input type="checkbox"/> No</p> <p><input type="checkbox"/> Yes <input type="checkbox"/> No</p> <p>Measurement:</p>	 <p>The diagrams illustrate the required clearances for a bench. The top diagram shows a 48-inch minimum clear floor space by 30-inch minimum clear floor space at the end of the bench. The middle diagram shows a 20-inch to 24-inch depth for the seat and a 42-inch minimum length for the seat. The bottom diagram shows a 17-inch to 19-inch height for the seat above the floor.</p>
---	---	--

Dining Tables Yes No

<p>5.28 Are at least 5 percent, but not less than one, of the dining surfaces for the seating and standing spaces accessible?</p> <p>Is/are the accessible space(s) distributed throughout the facility and located on an accessible route?</p>	<p><input type="checkbox"/> Yes <input type="checkbox"/> No</p> <p>Total #: Accessible #:</p> <p><input type="checkbox"/> Yes <input type="checkbox"/> No</p>	
--	---	--

ADA Checklist for Existing Facilities - Parks

City of Grand Rapids ADA Transition Plan

Building: Steamboat Landing

Location: _____

Date: 10/8/19

Evaluated By: Dom DeGuseppi

Priority 5 - Parks

5.1 Is there at least one route from site arrival points (parking, passenger loading zones, public sidewalks and public transportation stops) that does not require the use of stairs?
[See 2010 ADA Standards for Accessible Design – 206.2.1]

Yes No

If yes, location of route:

Parking Yes No

5.2 If parking is provided for the public, are an adequate number of accessible spaces provided?
[208.2]

Yes No

Total #:
Accessible #:

Total Spaces	Accessible Spaces
1 - 25	1
26 - 50	2
51 - 75	3
76 - 100	4
100+ see 2010 Standards 208.2	



5.3 Are accessible spaces at least 8 feet wide with an access aisle at least 8 feet wide?
[502.2, 502.3]

Yes No

Measurement:

Note: Two spaces may share an access aisle. Check state/local requirements;

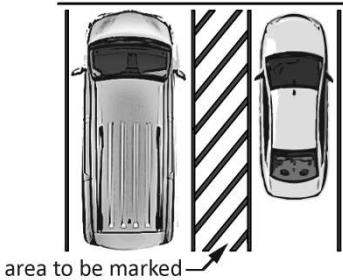
ADA Checklist for Existing Facilities - Parks

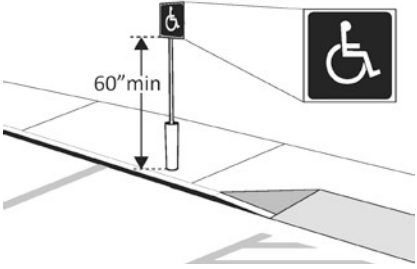
	some specify that each space have its own aisle.		
<p>5.4 Are the access aisles marked with signage and surface painting so as to discourage parking in them? [502.3.3]</p> <p>Note: The marking method and color may be addressed by state/local requirements.</p>	<p><input type="checkbox"/> Yes <input checked="" type="checkbox"/> No</p>		
<p>5.5 Is the slope of the accessible parking spaces and access aisles no steeper than 1:48 in all directions? [502.4]</p>	<p><input type="checkbox"/> Yes <input checked="" type="checkbox"/> No</p> <p>Measurement: NA</p>		
<p>5.6 Do the access aisles adjoin an accessible route? [502.3]</p>	<p><input type="checkbox"/> Yes <input checked="" type="checkbox"/> No</p>		
<p>5.7 Are accessible spaces identified with a sign that includes the International Symbol of Accessibility?</p> <p>Is the bottom of the sign at least 60 inches and not greater than 66 inches above the ground? [502.6]</p>	<p><input type="checkbox"/> Yes <input checked="" type="checkbox"/> No</p> <p><input type="checkbox"/> Yes <input checked="" type="checkbox"/> No</p> <p>Measurement:</p>		
<p>5.8 Of the total parking spaces, are the accessible spaces located on the closest accessible route to the accessible entrance(s)? [208.3.1]</p>	<p><input type="checkbox"/> Yes <input checked="" type="checkbox"/> No</p>		

Exterior Accessible Route

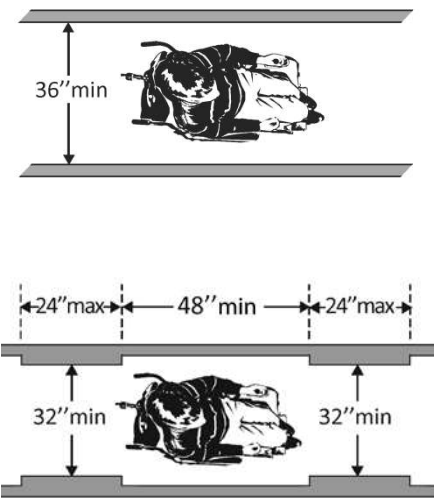
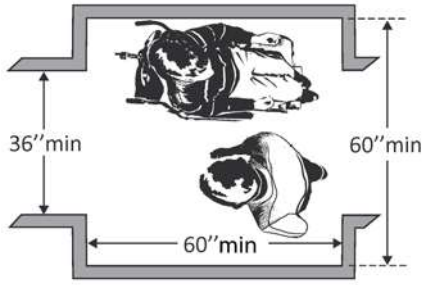
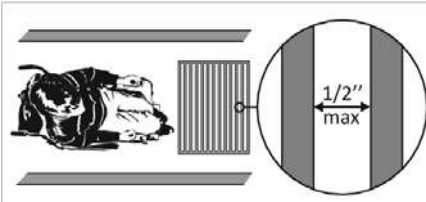
<p>5.9 Is the route stable, firm and slip-resistant? [302.1]</p>	<p><input checked="" type="checkbox"/> Yes <input type="checkbox"/> No</p>	
<p>5.10 Is the route at least 36 inches wide? [403.5.1]</p> <p>Note: The accessible route can narrow to 32 inches min. for a max. of 24 inches. These narrower portions of the route must be at least 48 inches from each other.</p>	<p><input checked="" type="checkbox"/> Yes <input type="checkbox"/> No</p> <p>Measurement: 10'</p>	
<p>5.11 If the route is greater than 200 feet in length and less than 60 inches wide, is there a passing space no less than 60 x 60 inches? [403.5.3]</p>	<p><input type="checkbox"/> Yes <input checked="" type="checkbox"/> No</p> <p>Measurement: NA</p>	
<p>5.12 If there are grates or openings on the route, are the openings no larger than 1/2 inches?</p>	<p>If the route is greater than 200 feet in length and less than 60 inches wide, is there a passing space no less than 60 x 60 inches? [403.5.3]</p>	

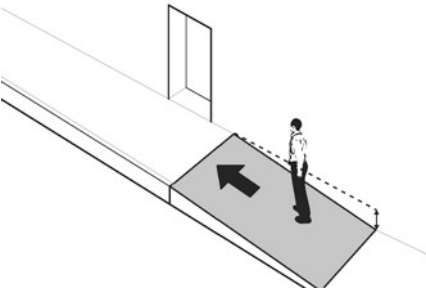
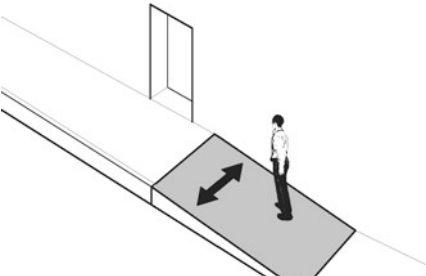
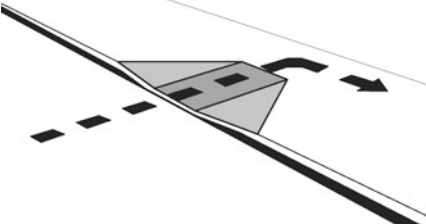
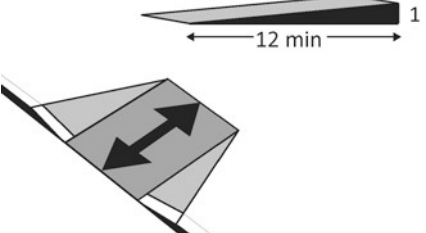
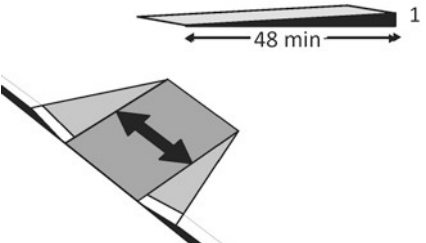
<p>5.13 Is the running slope no steeper than 1:20, i.e. for every inch of height change there are at least 20 inches of route run? [403.3]</p> <p>Note: If the running slope is steeper than 1:20, treat as a ramp and add features such as edge protection and handrails.</p>	<p><input checked="" type="checkbox"/> Yes <input type="checkbox"/> No</p> <p>Measurement: 3%</p>		
<p>5.14 Is the cross slope no steeper than 1:48? [403.3]</p>	<p><input checked="" type="checkbox"/> Yes <input type="checkbox"/> No</p> <p>Measurement: 1.1%</p>		
<p>Curb Ramps <input type="checkbox"/> Yes <input checked="" type="checkbox"/> No</p>			
<p>5.15 If the accessible route crosses a curb, is there a curb ramp? [402.2]</p>	<p><input type="checkbox"/> Yes <input type="checkbox"/> No</p>		
<p>5.16 Is the running slope of the curb ramp no steeper than 1:12, i.e. for every inch of height change there are at least 12 inches of curb ramp run? [406.1, 405.2]</p>	<p><input type="checkbox"/> Yes <input type="checkbox"/> No</p> <p>Measurement:</p>		
<p>5.17 Is the cross slope of the curb ramp, excluding flares, no steeper than 1:48? [406.1, 405.3]</p>	<p><input type="checkbox"/> Yes <input type="checkbox"/> No</p> <p>Measurement:</p>		

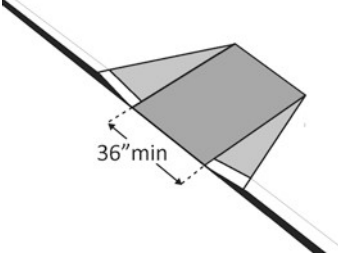
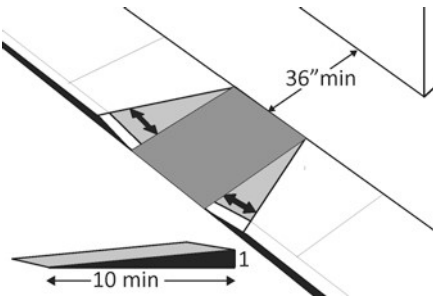
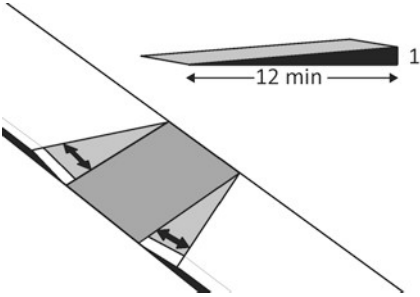
<p>5.18 Is the curb ramp, excluding flares, at least 36 inches wide? [406.1, 405.5]</p>	<p><input type="checkbox"/> Yes <input type="checkbox"/> No</p> <p>Measurement:</p>		
<p>5.19 At the top of the curb ramp is there a level landing (slope no steeper than 1:48 in all directions) that is at least 36 inches long and at least as wide as the curb ramp? [406.4]</p> <p>If there are curb ramp flares, are the slopes of the flares no steeper than 1:10, i.e. for every inch of height change there are at least 10 inches of flare run? [406.3]</p>	<p><input type="checkbox"/> Yes <input type="checkbox"/> No</p> <p>Measurement:</p> <p><input type="checkbox"/> Yes <input type="checkbox"/> No</p> <p>Measurement:</p>		
<p>5.20 If the landing at the top is less than 36 inches long, are there curb ramp flares? [406.4]</p> <p>Are the slopes of the flares no greater than 1:12, i.e. for every inch of height change there are at least 12 inches of flare run? [406.4]</p>	<p><input type="checkbox"/> Yes <input type="checkbox"/> No</p> <p><input type="checkbox"/> Yes <input type="checkbox"/> No</p> <p>Measurement:</p>		
<p>Accessible Play Components <input type="checkbox"/> Yes <input checked="" type="checkbox"/> No</p>			
<p>5.21 <u>Ground Level Play Components</u> Is there an accessible route to at least one of each type of ground level play component?</p> <p>Notes:</p> <ol style="list-style-type: none"> 1. A play component is an element designed to generate play, socialization and learning. 2. Ground level play components are components that can be approached and exited at 	<p><input type="checkbox"/> Yes <input type="checkbox"/> No</p>		

ADA Checklist for Existing Facilities - Parks

<p>ground level. Examples include rockers, swings, diggers and stand-alone slides.</p>			
<p>5.22 <u>Elevated Play Components</u> Are there any accessible elevated play components? If so, is there an accessible route to the components?</p>	<p><input type="checkbox"/> Yes <input type="checkbox"/> No <input type="checkbox"/> Yes <input type="checkbox"/> No</p>		
<p>5.23 Is the vertical clearance of the accessible route at least 80 inches above the ground surface? Note: Objects below 80 inches may not protrude into the accessible route.</p>	<p><input type="checkbox"/> Yes <input type="checkbox"/> No</p>		
<p>Pavilion <input type="checkbox"/> Yes <input checked="" type="checkbox"/> No</p>			
<p>5.24 Is there an accessible route that is stable, firm and slip-resistant? [302.1]</p>	<p><input type="checkbox"/> Yes <input type="checkbox"/> No</p>		
<p>5.25 Is the route at least 36 inches wide? [403.5.1]</p>	<p><input type="checkbox"/> Yes <input type="checkbox"/> No</p>		
<p>5.26 Is the running slope no steeper than 1:20, i.e. for every inch of height change there are at least 20 inches of route run? [403.3] Note: If the running slope is steeper than 1:20, treat as a ramp and add features such as edge protection and handrails.</p>	<p><input type="checkbox"/> Yes <input type="checkbox"/> No Measurement:</p>		

ADA Checklist for Existing Facilities - Parks

<p>5.27 Is the cross slope no steeper than 1:48? [403.3]</p>	<p><input type="checkbox"/> Yes <input type="checkbox"/> No</p> <p>Measurement:</p>	
---	---	--

Benches Yes No

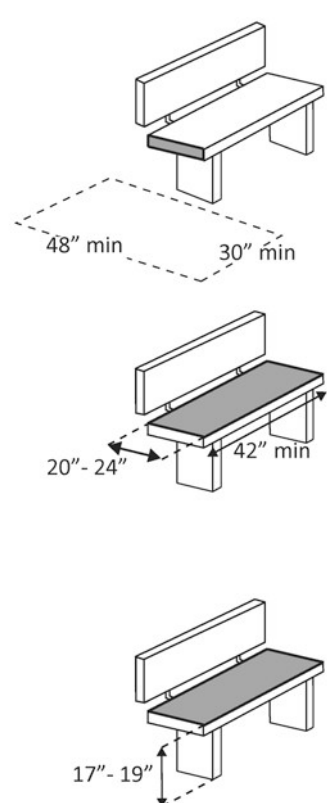
<p>5.28 Is there a clear floor space at least 30 inches wide by at least 48 inches long at the end of the bench and parallel to the short axis of the bench?</p> <p>Is the bench seat at least 42 inches long and no less than 20 inches and no greater than 24 inches deep?</p> <p>Does the bench have back support or is it affixed to a wall?</p> <p>Is the top of the bench seat no less than 17 inches and no greater than 19 inches above the floor? [903]</p>	<p><input type="checkbox"/> Yes <input type="checkbox"/> No</p> <p>Measurement:</p> <p><input type="checkbox"/> Yes <input type="checkbox"/> No</p> <p>Measurement:</p> <p><input type="checkbox"/> Yes <input type="checkbox"/> No</p> <p><input type="checkbox"/> Yes <input type="checkbox"/> No</p> <p>Measurement:</p>	 <p>The diagrams illustrate the required clearances for a bench. The top diagram shows a 48" x 30" clear floor space at the end of the bench. The middle diagram shows a seat depth of 20"-24" and a seat length of 42" min. The bottom diagram shows a seat height of 17"-19" above the floor.</p>
---	---	--

Dining Tables Yes No

<p>5.28 Are at least 5 percent, but not less than one, of the dining surfaces for the seating and standing spaces accessible?</p> <p>Is/are the accessible space(s) distributed throughout the facility and located on an accessible route?</p>	<p><input type="checkbox"/> Yes <input type="checkbox"/> No</p> <p>Total #: Accessible #:</p> <p><input type="checkbox"/> Yes <input type="checkbox"/> No</p>	
--	---	--

ADA Checklist for Existing Facilities - Parks

City of Grand Rapids ADA Transition Plan

Building: Sylvan Landing

Location: SW 1st Street

Date: 10/2/19

Evaluated By: Dom DeGuseppi

Priority 5 - Parks



5.1	Is there at least one route from site arrival points (parking, passenger loading zones, public sidewalks and public transportation stops) that does not require the use of stairs? [See 2010 ADA Standards for Accessible Design – 206.2.1]	<input type="checkbox"/> Yes <input checked="" type="checkbox"/> No If yes, location of route:		
-----	--	---	--	--

Parking Yes No

5.2	If parking is provided for the public, are an adequate number of accessible spaces provided? [208.2]	<input type="checkbox"/> Yes <input checked="" type="checkbox"/> No Total #: 3 Accessible #: 0	<table border="1"> <thead> <tr> <th>Total Spaces</th> <th>Accessible Spaces</th> </tr> </thead> <tbody> <tr> <td>1 - 25</td> <td>1</td> </tr> <tr> <td>26 - 50</td> <td>2</td> </tr> <tr> <td>51 - 75</td> <td>3</td> </tr> <tr> <td>76 - 100</td> <td>4</td> </tr> <tr> <td colspan="2">100+ see 2010 Standards 208.2</td> </tr> </tbody> </table>	Total Spaces	Accessible Spaces	1 - 25	1	26 - 50	2	51 - 75	3	76 - 100	4	100+ see 2010 Standards 208.2			Additional parking but not marked
Total Spaces	Accessible Spaces																
1 - 25	1																
26 - 50	2																
51 - 75	3																
76 - 100	4																
100+ see 2010 Standards 208.2																	

5.3	Are accessible spaces at least 8 feet wide with an access aisle at least 8 feet wide? [502.2, 502.3] Note: Two spaces may share an access aisle. Check state/local requirements;	<input type="checkbox"/> Yes <input checked="" type="checkbox"/> No Measurement:		
-----	--	---	--	--

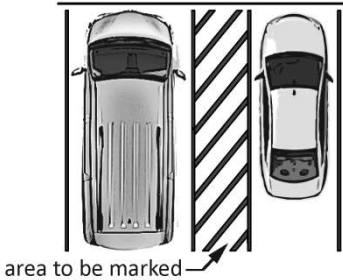
ADA Checklist for Existing Facilities - Parks

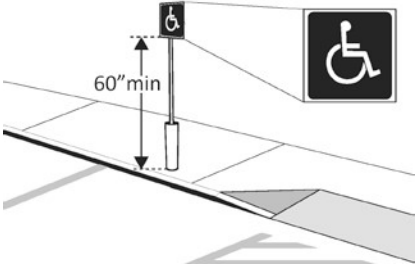
	some specify that each space have its own aisle.		
<p>5.4 Are the access aisles marked with signage and surface painting so as to discourage parking in them? [502.3.3]</p> <p>Note: The marking method and color may be addressed by state/local requirements.</p>	<p><input type="checkbox"/> Yes <input checked="" type="checkbox"/> No</p>		
<p>5.5 Is the slope of the accessible parking spaces and access aisles no steeper than 1:48 in all directions? [502.4]</p>	<p><input type="checkbox"/> Yes <input checked="" type="checkbox"/> No</p> <p>Measurement: NA</p>		
<p>5.6 Do the access aisles adjoin an accessible route? [502.3]</p>	<p><input type="checkbox"/> Yes <input checked="" type="checkbox"/> No</p>		
<p>5.7 Are accessible spaces identified with a sign that includes the International Symbol of Accessibility?</p> <p>Is the bottom of the sign at least 60 inches and not greater than 66 inches above the ground? [502.6]</p>	<p><input type="checkbox"/> Yes <input checked="" type="checkbox"/> No</p> <p><input type="checkbox"/> Yes <input checked="" type="checkbox"/> No</p> <p>Measurement:</p>		
<p>5.8 Of the total parking spaces, are the accessible spaces located on the closest accessible route to the accessible entrance(s)? [208.3.1]</p>	<p><input type="checkbox"/> Yes <input checked="" type="checkbox"/> No</p>		

Exterior Accessible Route

5.9 Is the route stable, firm and slip-resistant? [302.1] Yes No

5.10 Is the route at least 36 inches wide? [403.5.1] Yes No
Measurement:

Note: The accessible route can narrow to 32 inches min. for a max. of 24 inches. These narrower portions of the route must be at least 48 inches from each other.

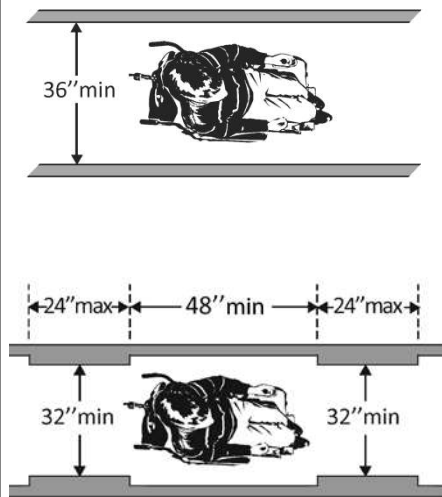

5.11 If the route is greater than 200 feet in length and less than 60 inches wide, is there a passing space no less than 60 x 60 inches? [403.5.3] Yes No
Measurement:

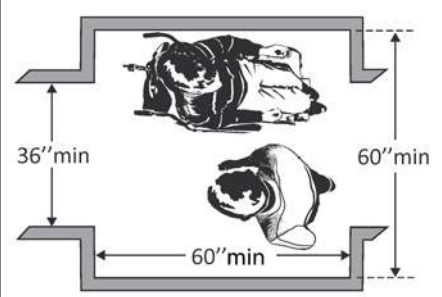

5.12 If there are grates or openings on the route, are the openings no larger than 1/2 inches? [403.5.3] If the route is greater than 200 feet in length and less than 60 inches wide, is there a passing space no less than 60 x 60 inches?

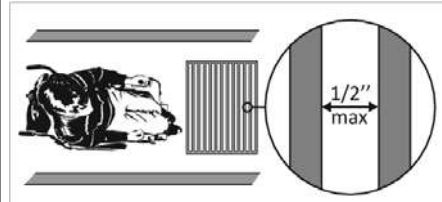

ADA Checklist for Existing Facilities - Parks

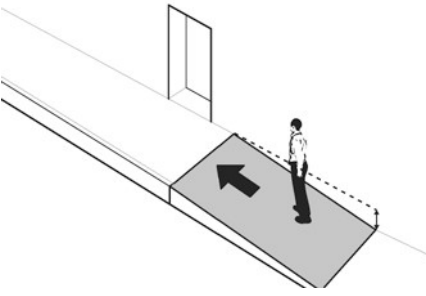
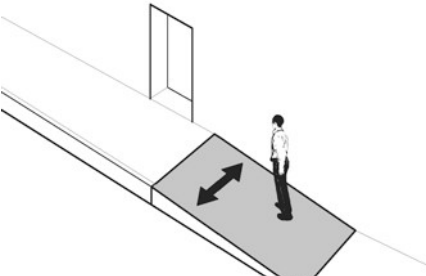
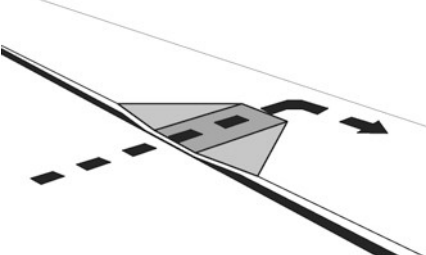
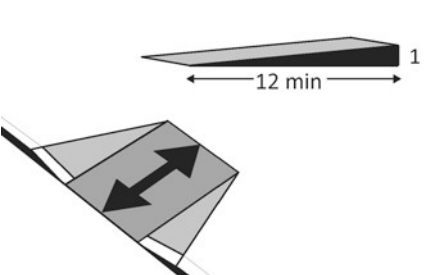
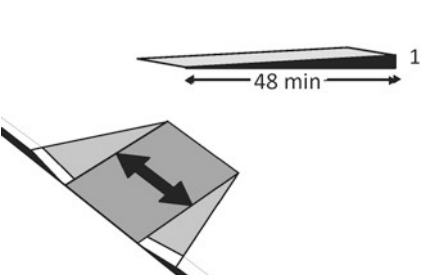
<p>5.13 Is the running slope no steeper than 1:20, i.e. for every inch of height change there are at least 20 inches of route run? [403.3]</p> <p>Note: If the running slope is steeper than 1:20, treat as a ramp and add features such as edge protection and handrails.</p>	<p><input type="checkbox"/> Yes <input checked="" type="checkbox"/> No</p> <p>Measurement:</p>		
<p>5.14 Is the cross slope no steeper than 1:48? [403.3]</p>	<p><input type="checkbox"/> Yes <input checked="" type="checkbox"/> No</p> <p>Measurement:</p>		
<p>Curb Ramps <input checked="" type="checkbox"/> Yes <input type="checkbox"/> No</p>			
<p>5.15 If the accessible route crosses a curb, is there a curb ramp? [402.2]</p>	<p><input checked="" type="checkbox"/> Yes <input type="checkbox"/> No</p>		
<p>5.16 Is the running slope of the curb ramp no steeper than 1:12, i.e. for every inch of height change there are at least 12 inches of curb ramp run? [406.1, 405.2]</p>	<p><input type="checkbox"/> Yes <input checked="" type="checkbox"/> No</p> <p>Measurement: 5.8%</p>		
<p>5.17 Is the cross slope of the curb ramp, excluding flares, no steeper than 1:48? [406.1, 405.3]</p>	<p><input checked="" type="checkbox"/> Yes <input type="checkbox"/> No</p> <p>Measurement: 1.2%</p>		

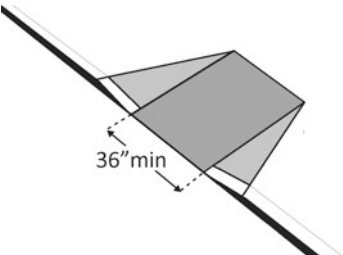
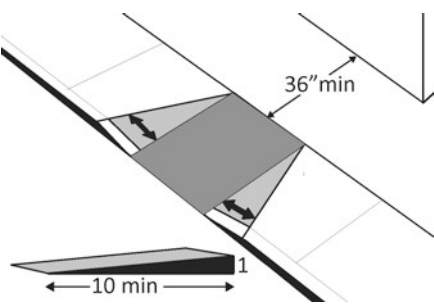
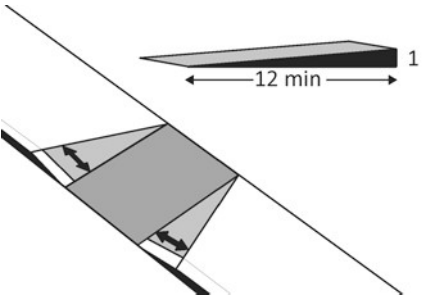
<p>5.18 Is the curb ramp, excluding flares, at least 36 inches wide? [406.1, 405.5]</p>	<p><input checked="" type="checkbox"/> Yes <input type="checkbox"/> No</p> <p>Measurement: 60"</p>		
<p>5.19 At the top of the curb ramp is there a level landing (slope no steeper than 1:48 in all directions) that is at least 36 inches long and at least as wide as the curb ramp? [406.4]</p> <p>If there are curb ramp flares, are the slopes of the flares no steeper than 1:10, i.e. for every inch of height change there are at least 10 inches of flare run? [406.3]</p>	<p><input type="checkbox"/> Yes <input checked="" type="checkbox"/> No</p> <p>Measurement:</p> <p><input type="checkbox"/> Yes <input checked="" type="checkbox"/> No</p> <p>Measurement:</p>		
<p>5.20 If the landing at the top is less than 36 inches long, are there curb ramp flares? [406.4]</p> <p>Are the slopes of the flares no greater than 1:12, i.e. for every inch of height change there are at least 12 inches of flare run? [406.4]</p>	<p><input type="checkbox"/> Yes <input checked="" type="checkbox"/> No</p> <p><input type="checkbox"/> Yes <input checked="" type="checkbox"/> No</p> <p>Measurement:</p>		
<p>Accessible Play Components <input type="checkbox"/> Yes <input checked="" type="checkbox"/> No</p>			
<p>5.21 <u>Ground Level Play Components</u> Is there an accessible route to at least one of each type of ground level play component? [406.4]</p> <p>Notes:</p> <ol style="list-style-type: none"> 1. A play component is an element designed to generate play, socialization and learning. 2. Ground level play components are components that can be approached and exited at 	<p><input type="checkbox"/> Yes <input type="checkbox"/> No</p>		

ADA Checklist for Existing Facilities - Parks

<p>ground level. Examples include rockers, swings, diggers and stand-alone slides.</p>			
<p>5.22 <u>Elevated Play Components</u> Are there any accessible elevated play components? If so, is there an accessible route to the components?</p>	<p><input type="checkbox"/> Yes <input type="checkbox"/> No <input type="checkbox"/> Yes <input type="checkbox"/> No</p>		
<p>5.23 Is the vertical clearance of the accessible route at least 80 inches above the ground surface? Note: Objects below 80 inches may not protrude into the accessible route.</p>	<p><input type="checkbox"/> Yes <input type="checkbox"/> No</p>		
<p>Pavilion <input type="checkbox"/> Yes <input checked="" type="checkbox"/> No</p>			
<p>5.24 Is there an accessible route that is stable, firm and slip-resistant? [302.1]</p>	<p><input type="checkbox"/> Yes <input type="checkbox"/> No</p>		
<p>5.25 Is the route at least 36 inches wide? [403.5.1]</p>	<p><input type="checkbox"/> Yes <input type="checkbox"/> No</p>		
<p>5.26 Is the running slope no steeper than 1:20, i.e. for every inch of height change there are at least 20 inches of route run? [403.3] Note: If the running slope is steeper than 1:20, treat as a ramp and add features such as edge protection and handrails.</p>	<p><input type="checkbox"/> Yes <input type="checkbox"/> No Measurement:</p>		

ADA Checklist for Existing Facilities - Parks

<p>5.27 Is the cross slope no steeper than 1:48? [403.3]</p>	<p><input type="checkbox"/> Yes <input type="checkbox"/> No</p> <p>Measurement:</p>	
---	---	--

Benches Yes No

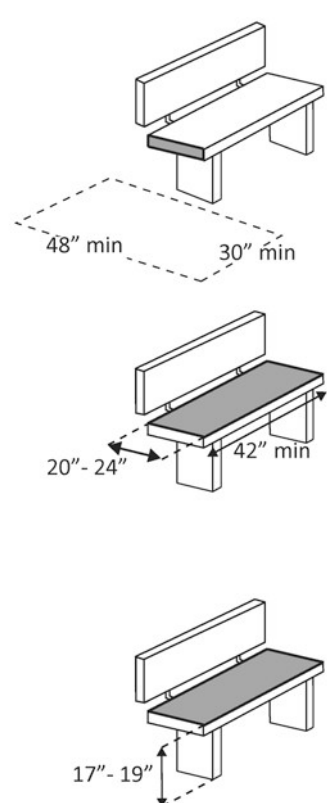
<p>5.28 Is there a clear floor space at least 30 inches wide by at least 48 inches long at the end of the bench and parallel to the short axis of the bench?</p> <p>Is the bench seat at least 42 inches long and no less than 20 inches and no greater than 24 inches deep?</p> <p>Does the bench have back support or is it affixed to a wall?</p> <p>Is the top of the bench seat no less than 17 inches and no greater than 19 inches above the floor? [903]</p>	<p><input checked="" type="checkbox"/> Yes <input type="checkbox"/> No</p> <p>Measurement:</p> <p><input checked="" type="checkbox"/> Yes <input type="checkbox"/> No</p> <p>Measurement:</p> <p>70"</p> <p><input checked="" type="checkbox"/> Yes <input type="checkbox"/> No</p> <p><input checked="" type="checkbox"/> Yes <input type="checkbox"/> No</p> <p>Measurement:</p> <p>17"</p>	
---	---	---

Dining Tables Yes No

<p>5.28 Are at least 5 percent, but not less than one, of the dining surfaces for the seating and standing spaces accessible?</p> <p>Is/are the accessible space(s) distributed throughout the facility and located on an accessible route?</p>	<p><input checked="" type="checkbox"/> Yes <input type="checkbox"/> No</p> <p>Total #: 2 Accessible #: 1</p> <p><input checked="" type="checkbox"/> Yes <input type="checkbox"/> No</p>	
--	---	--

ADA Checklist for Existing Facilities - Parks

City of Grand Rapids ADA Transition Plan

Building: Sylvan Point Trail

Location: SW 14th Ave

Date: 10/2/19

Evaluated By: Dom DeGuseppi

Priority 5 - Parks

5.1 Is there at least one route from site arrival points (parking, passenger loading zones, public sidewalks and public transportation stops) that does not require the use of stairs?
[See 2010 ADA Standards for Accessible Design – 206.2.1]

Yes No

If yes, location of route:

Parking Yes No

5.2 If parking is provided for the public, are an adequate number of accessible spaces provided?
[208.2]

Yes No

Total #:	Total Spaces	Accessible Spaces	Dirt lot
Accessible #:	1 - 25	1	
	26 - 50	2	
	51 - 75	3	
	76 - 100	4	
	100+ see 2010 Standards 208.2		



5.3 Are accessible spaces at least 8 feet wide with an access aisle at least 8 feet wide?
[502.2, 502.3]

Yes No

Measurement:

Note: Two spaces may share an access aisle. Check state/local requirements;

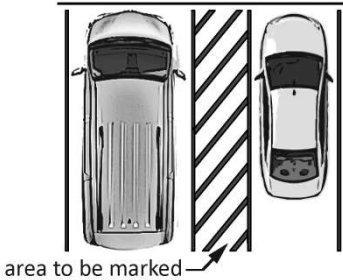
ADA Checklist for Existing Facilities - Parks

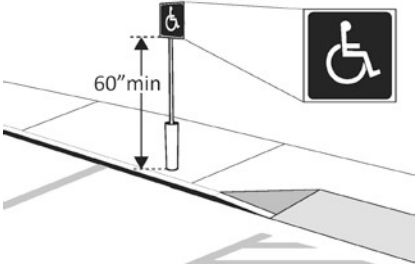
	some specify that each space have its own aisle.			
5.4	<p>Are the access aisles marked with signage and surface painting so as to discourage parking in them? [502.3.3]</p> <p>Note: The marking method and color may be addressed by state/local requirements.</p>	<input type="checkbox"/> Yes <input checked="" type="checkbox"/> No		
5.5	<p>Is the slope of the accessible parking spaces and access aisles no steeper than 1:48 in all directions? [502.4]</p>	<input type="checkbox"/> Yes <input checked="" type="checkbox"/> No Measurement:		
5.6	<p>Do the access aisles adjoin an accessible route? [502.3]</p>	<input type="checkbox"/> Yes <input checked="" type="checkbox"/> No		
5.7	<p>Are accessible spaces identified with a sign that includes the International Symbol of Accessibility? Is the bottom of the sign at least 60 inches and not greater than 66 inches above the ground? [502.6]</p>	<input type="checkbox"/> Yes <input checked="" type="checkbox"/> No <input type="checkbox"/> Yes <input checked="" type="checkbox"/> No Measurement:		
5.8	<p>Of the total parking spaces, are the accessible spaces located on the closest accessible route to the accessible entrance(s)? [208.3.1]</p>	<input type="checkbox"/> Yes <input checked="" type="checkbox"/> No		

Exterior Accessible Route

5.9 Is the route stable, firm and slip-resistant?
[302.1] Yes No

5.10 Is the route at least 36 inches wide?
[403.5.1] Yes No

Measurement:

Note: The accessible route can narrow to 32 inches min. for a max. of 24 inches. These narrower portions of the route must be at least 48 inches from each other.

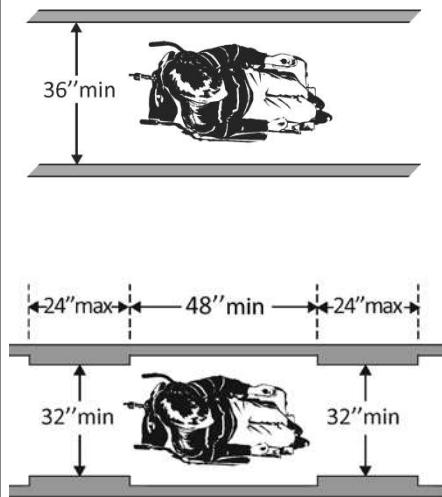

5.11 If the route is greater than 200 feet in length and less than 60 inches wide, is there a passing space no less than 60 x 60 inches?
[403.5.3] Yes No

Measurement:

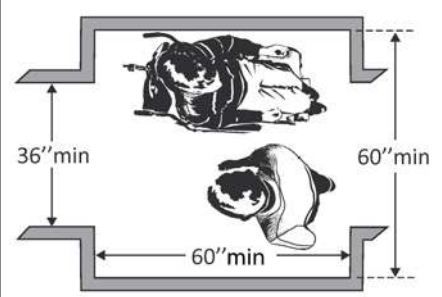

5.12 If there are grates or openings on the route, are the openings no larger than 1/2 inches?
[403.5.3]

If the route is greater than 200 feet in length and less than 60 inches wide, is there a passing space no less than 60 x 60 inches?
[403.5.3]

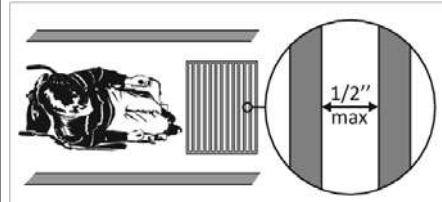

ADA Checklist for Existing Facilities - Parks

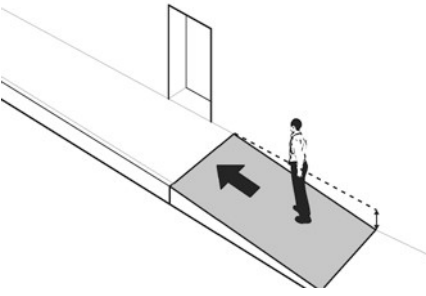
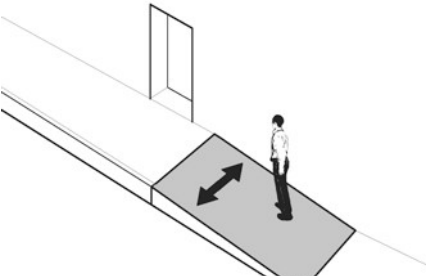
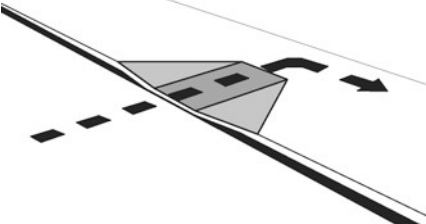
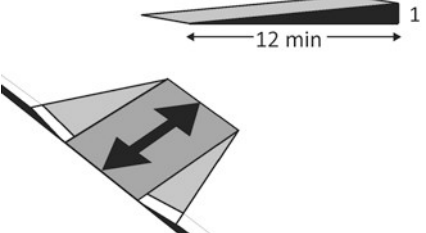
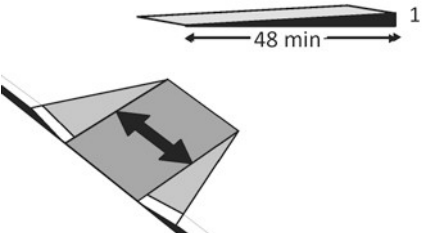
<p>5.13 Is the running slope no steeper than 1:20, i.e. for every inch of height change there are at least 20 inches of route run? [403.3]</p> <p>Note: If the running slope is steeper than 1:20, treat as a ramp and add features such as edge protection and handrails.</p>	<p><input type="checkbox"/> Yes <input checked="" type="checkbox"/> No</p> <p>Measurement:</p>		
<p>5.14 Is the cross slope no steeper than 1:48? [403.3]</p>	<p><input type="checkbox"/> Yes <input checked="" type="checkbox"/> No</p> <p>Measurement:</p>		
<p>Curb Ramps <input type="checkbox"/> Yes <input checked="" type="checkbox"/> No</p>			
<p>5.15 If the accessible route crosses a curb, is there a curb ramp? [402.2]</p>	<p><input type="checkbox"/> Yes <input type="checkbox"/> No</p>		
<p>5.16 Is the running slope of the curb ramp no steeper than 1:12, i.e. for every inch of height change there are at least 12 inches of curb ramp run? [406.1, 405.2]</p>	<p><input type="checkbox"/> Yes <input type="checkbox"/> No</p> <p>Measurement:</p>		
<p>5.17 Is the cross slope of the curb ramp, excluding flares, no steeper than 1:48? [406.1, 405.3]</p>	<p><input type="checkbox"/> Yes <input type="checkbox"/> No</p> <p>Measurement:</p>		

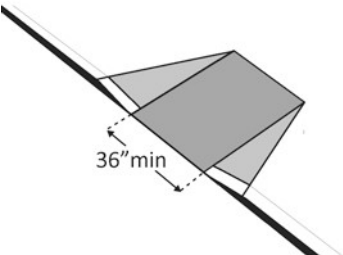
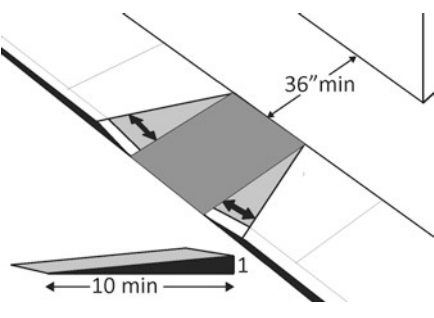
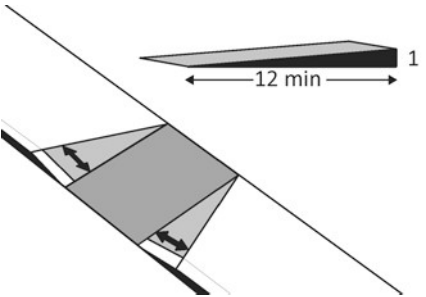
<p>5.18 Is the curb ramp, excluding flares, at least 36 inches wide? [406.1, 405.5]</p>	<p><input type="checkbox"/> Yes <input type="checkbox"/> No</p> <p>Measurement:</p>		
<p>5.19 At the top of the curb ramp is there a level landing (slope no steeper than 1:48 in all directions) that is at least 36 inches long and at least as wide as the curb ramp? [406.4]</p> <p>If there are curb ramp flares, are the slopes of the flares no steeper than 1:10, i.e. for every inch of height change there are at least 10 inches of flare run? [406.3]</p>	<p><input type="checkbox"/> Yes <input type="checkbox"/> No</p> <p>Measurement:</p> <p><input type="checkbox"/> Yes <input type="checkbox"/> No</p> <p>Measurement:</p>		
<p>5.20 If the landing at the top is less than 36 inches long, are there curb ramp flares? [406.4]</p> <p>Are the slopes of the flares no greater than 1:12, i.e. for every inch of height change there are at least 12 inches of flare run? [406.4]</p>	<p><input type="checkbox"/> Yes <input type="checkbox"/> No</p> <p><input type="checkbox"/> Yes <input type="checkbox"/> No</p> <p>Measurement:</p>		
<p>Accessible Play Components <input type="checkbox"/> Yes <input checked="" type="checkbox"/> No</p>			
<p>5.21 <u>Ground Level Play Components</u> Is there an accessible route to at least one of each type of ground level play component?</p> <p>Notes:</p> <ol style="list-style-type: none"> 1. A play component is an element designed to generate play, socialization and learning. 2. Ground level play components are components that can be approached and exited at 	<p><input type="checkbox"/> Yes <input type="checkbox"/> No</p>		

ADA Checklist for Existing Facilities - Parks

<p>ground level. Examples include rockers, swings, diggers and stand-alone slides.</p>			
<p>5.22 <u>Elevated Play Components</u> Are there any accessible elevated play components? If so, is there an accessible route to the components?</p>	<p><input type="checkbox"/> Yes <input type="checkbox"/> No <input type="checkbox"/> Yes <input type="checkbox"/> No</p>		
<p>5.23 Is the vertical clearance of the accessible route at least 80 inches above the ground surface? Note: Objects below 80 inches may not protrude into the accessible route.</p>	<p><input type="checkbox"/> Yes <input type="checkbox"/> No</p>		
<p>Pavilion <input type="checkbox"/> Yes <input checked="" type="checkbox"/> No</p>			
<p>5.24 Is there an accessible route that is stable, firm and slip-resistant? [302.1]</p>	<p><input type="checkbox"/> Yes <input type="checkbox"/> No</p>		
<p>5.25 Is the route at least 36 inches wide? [403.5.1]</p>	<p><input type="checkbox"/> Yes <input type="checkbox"/> No</p>		
<p>5.26 Is the running slope no steeper than 1:20, i.e. for every inch of height change there are at least 20 inches of route run? [403.3] Note: If the running slope is steeper than 1:20, treat as a ramp and add features such as edge protection and handrails.</p>	<p><input type="checkbox"/> Yes <input type="checkbox"/> No Measurement:</p>		

ADA Checklist for Existing Facilities - Parks

<p>5.27 Is the cross slope no steeper than 1:48? [403.3]</p>	<p><input type="checkbox"/> Yes <input type="checkbox"/> No</p> <p>Measurement:</p>	
---	---	--

Benches Yes No

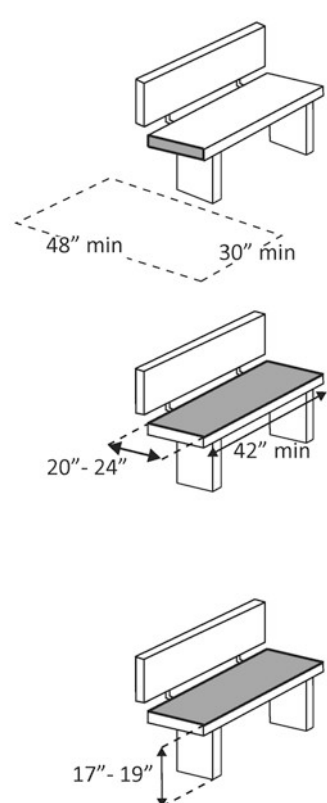
<p>5.28 Is there a clear floor space at least 30 inches wide by at least 48 inches long at the end of the bench and parallel to the short axis of the bench?</p> <p>Is the bench seat at least 42 inches long and no less than 20 inches and no greater than 24 inches deep?</p> <p>Does the bench have back support or is it affixed to a wall?</p> <p>Is the top of the bench seat no less than 17 inches and no greater than 19 inches above the floor? [903]</p>	<p><input type="checkbox"/> Yes <input type="checkbox"/> No</p> <p>Measurement:</p> <p><input type="checkbox"/> Yes <input type="checkbox"/> No</p> <p>Measurement:</p> <p><input type="checkbox"/> Yes <input type="checkbox"/> No</p> <p><input type="checkbox"/> Yes <input type="checkbox"/> No</p> <p>Measurement:</p>	 <p>The diagrams illustrate the ADA requirements for benches. The top diagram shows a side view of a bench with a dashed rectangle indicating a clear floor space of at least 48 inches by 30 inches at the end of the seat. The middle diagram shows a top-down view of the bench seat, with arrows indicating a minimum length of 42 inches and a depth between 20 and 24 inches. The bottom diagram shows a side view of the bench seat, with an arrow indicating a height between 17 and 19 inches above the ground.</p>
---	---	---

Dining Tables Yes No

<p>5.28 Are at least 5 percent, but not less than one, of the dining surfaces for the seating and standing spaces accessible?</p> <p>Is/are the accessible space(s) distributed throughout the facility and located on an accessible route?</p>	<p><input type="checkbox"/> Yes <input type="checkbox"/> No</p> <p>Total #: Accessible #:</p> <p><input type="checkbox"/> Yes <input type="checkbox"/> No</p>	
--	---	--

ADA Checklist for Existing Facilities - Parks

City of Grand Rapids ADA Transition Plan

Building: Veteran's Memorial Park

Location: _____

Date: 10/8/19

Evaluated By: Dom DeGuseppi

Priority 5 - Parks

5.1 Is there at least one route from site arrival points (parking, passenger loading zones, public sidewalks and public transportation stops) that does not require the use of stairs?
[See 2010 ADA Standards for Accessible Design – 206.2.1]

Yes No

If yes, location of route:

Parking Yes No

5.2 If parking is provided for the public, are an adequate number of accessible spaces provided? [208.2]	<input type="checkbox"/> Yes <input checked="" type="checkbox"/> No Total #: Accessible #: NA	Total Spaces	Accessible Spaces	Grass and gravel lot, no paved parking
		1 - 25	1	
		26 - 50	2	
		51 - 75	3	
		76 - 100	4	
		100+ see 2010 Standards 208.2		



5.3 Are accessible spaces at least 8 feet wide with an access aisle at least 8 feet wide?
[502.2, 502.3]

Yes No

Measurement:

Note: Two spaces may share an access aisle. Check state/local requirements;

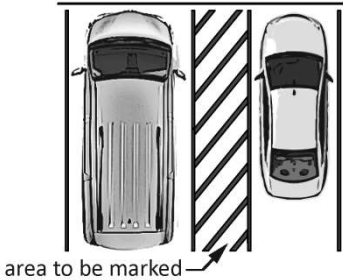
ADA Checklist for Existing Facilities - Parks

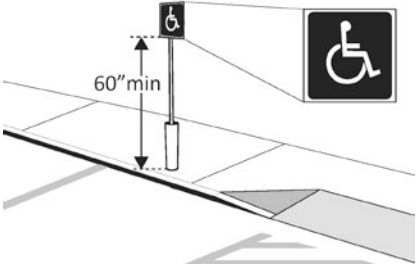
	some specify that each space have its own aisle.		
<p>5.4 Are the access aisles marked with signage and surface painting so as to discourage parking in them? [502.3.3]</p> <p>Note: The marking method and color may be addressed by state/local requirements.</p>	<p><input type="checkbox"/> Yes <input checked="" type="checkbox"/> No</p>		
<p>5.5 Is the slope of the accessible parking spaces and access aisles no steeper than 1:48 in all directions? [502.4]</p>	<p><input type="checkbox"/> Yes <input checked="" type="checkbox"/> No</p> <p>Measurement:</p>		
<p>5.6 Do the access aisles adjoin an accessible route? [502.3]</p>	<p><input type="checkbox"/> Yes <input checked="" type="checkbox"/> No</p>		
<p>5.7 Are accessible spaces identified with a sign that includes the International Symbol of Accessibility?</p> <p>Is the bottom of the sign at least 60 inches and not greater than 66 inches above the ground? [502.6]</p>	<p><input type="checkbox"/> Yes <input checked="" type="checkbox"/> No</p> <p><input type="checkbox"/> Yes <input checked="" type="checkbox"/> No</p> <p>Measurement:</p>		
<p>5.8 Of the total parking spaces, are the accessible spaces located on the closest accessible route to the accessible entrance(s)? [208.3.1]</p>	<p><input type="checkbox"/> Yes <input checked="" type="checkbox"/> No</p>		

Exterior Accessible Route

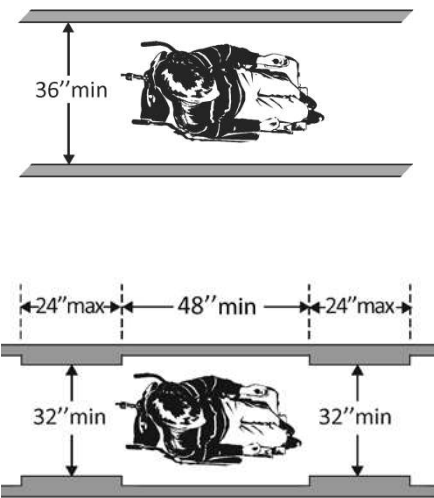
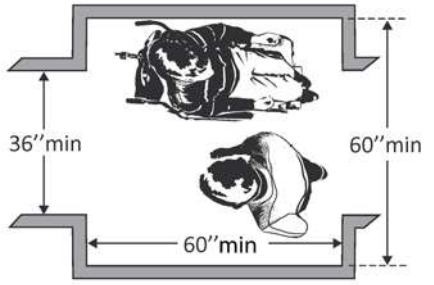
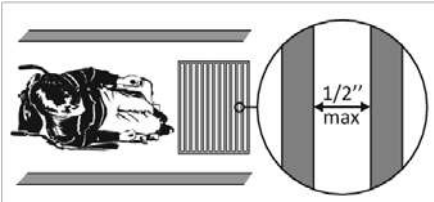
<p>5.9 Is the route stable, firm and slip-resistant? [302.1]</p>	<p><input checked="" type="checkbox"/> Yes <input type="checkbox"/> No</p>	
<p>5.10 Is the route at least 36 inches wide? [403.5.1]</p> <p>Note: The accessible route can narrow to 32 inches min. for a max. of 24 inches. These narrower portions of the route must be at least 48 inches from each other.</p>	<p><input checked="" type="checkbox"/> Yes <input type="checkbox"/> No</p> <p>Measurement: 9'</p>	
<p>5.11 If the route is greater than 200 feet in length and less than 60 inches wide, is there a passing space no less than 60 x 60 inches? [403.5.3]</p>	<p><input type="checkbox"/> Yes <input checked="" type="checkbox"/> No</p> <p>Measurement: NA</p>	
<p>5.12 If there are grates or openings on the route, are the openings no larger than 1/2 inches? [403.5.3]</p>	<p>If the route is greater than 200 feet in length and less than 60 inches wide, is there a passing space no less than 60 x 60 inches? [403.5.3]</p>	

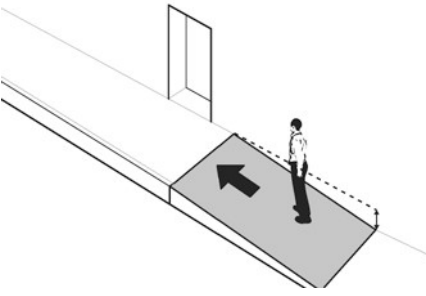
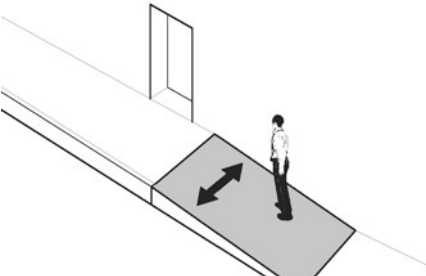
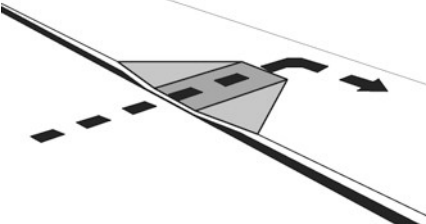
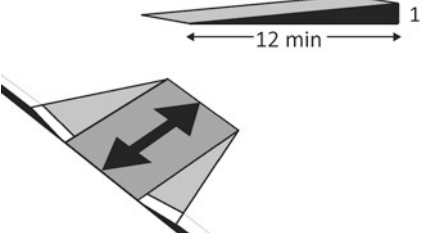
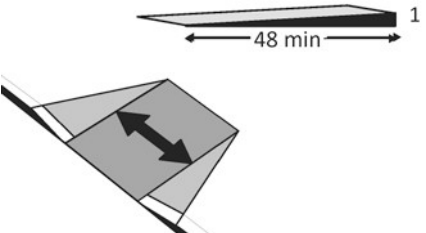
<p>5.13 Is the running slope no steeper than 1:20, i.e. for every inch of height change there are at least 20 inches of route run? [403.3]</p> <p>Note: If the running slope is steeper than 1:20, treat as a ramp and add features such as edge protection and handrails.</p>	<p><input checked="" type="checkbox"/> Yes <input type="checkbox"/> No</p> <p>Measurement: .5%</p>		
<p>5.14 Is the cross slope no steeper than 1:48? [403.3]</p>	<p><input checked="" type="checkbox"/> Yes <input type="checkbox"/> No</p> <p>Measurement: 1.4%</p>		
<p>Curb Ramps <input type="checkbox"/> Yes <input checked="" type="checkbox"/> No</p>			
<p>5.15 If the accessible route crosses a curb, is there a curb ramp? [402.2]</p>	<p><input type="checkbox"/> Yes <input type="checkbox"/> No</p>		
<p>5.16 Is the running slope of the curb ramp no steeper than 1:12, i.e. for every inch of height change there are at least 12 inches of curb ramp run? [406.1, 405.2]</p>	<p><input type="checkbox"/> Yes <input type="checkbox"/> No</p> <p>Measurement:</p>		
<p>5.17 Is the cross slope of the curb ramp, excluding flares, no steeper than 1:48? [406.1, 405.3]</p>	<p><input type="checkbox"/> Yes <input type="checkbox"/> No</p> <p>Measurement:</p>		

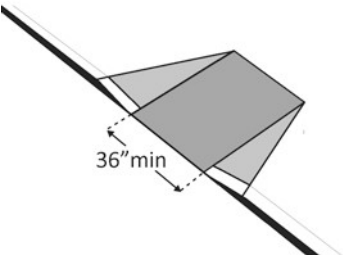
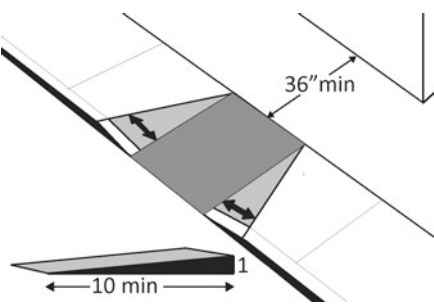
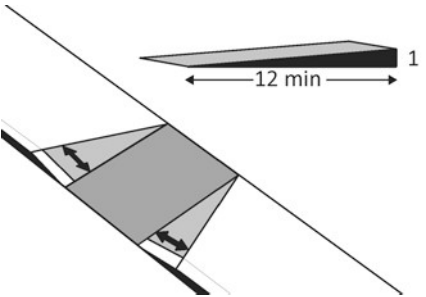
<p>5.18 Is the curb ramp, excluding flares, at least 36 inches wide? [406.1, 405.5]</p>	<p><input type="checkbox"/> Yes <input type="checkbox"/> No</p> <p>Measurement:</p>		
<p>5.19 At the top of the curb ramp is there a level landing (slope no steeper than 1:48 in all directions) that is at least 36 inches long and at least as wide as the curb ramp? [406.4]</p> <p>If there are curb ramp flares, are the slopes of the flares no steeper than 1:10, i.e. for every inch of height change there are at least 10 inches of flare run? [406.3]</p>	<p><input type="checkbox"/> Yes <input type="checkbox"/> No</p> <p>Measurement:</p> <p><input type="checkbox"/> Yes <input type="checkbox"/> No</p> <p>Measurement:</p>		
<p>5.20 If the landing at the top is less than 36 inches long, are there curb ramp flares? [406.4]</p> <p>Are the slopes of the flares no greater than 1:12, i.e. for every inch of height change there are at least 12 inches of flare run? [406.4]</p>	<p><input type="checkbox"/> Yes <input type="checkbox"/> No</p> <p><input type="checkbox"/> Yes <input type="checkbox"/> No</p> <p>Measurement:</p>		
<p>Accessible Play Components <input type="checkbox"/> Yes <input checked="" type="checkbox"/> No</p>			
<p>5.21 <u>Ground Level Play Components</u> Is there an accessible route to at least one of each type of ground level play component?</p> <p>Notes:</p> <ol style="list-style-type: none"> 1. A play component is an element designed to generate play, socialization and learning. 2. Ground level play components are components that can be approached and exited at 	<p><input type="checkbox"/> Yes <input checked="" type="checkbox"/> No</p>		

ADA Checklist for Existing Facilities - Parks

<p>ground level. Examples include rockers, swings, diggers and stand-alone slides.</p>			
<p>5.22 <u>Elevated Play Components</u> Are there any accessible elevated play components?</p> <p>If so, is there an accessible route to the components?</p>	<p><input type="checkbox"/> Yes <input checked="" type="checkbox"/> No</p> <p><input type="checkbox"/> Yes <input checked="" type="checkbox"/> No</p>		
<p>5.23 Is the vertical clearance of the accessible route at least 80 inches above the ground surface?</p> <p>Note: Objects below 80 inches may not protrude into the accessible route.</p>	<p><input checked="" type="checkbox"/> Yes <input type="checkbox"/> No</p>		
<p>Pavilion <input checked="" type="checkbox"/> Yes <input type="checkbox"/> No</p>			
<p>5.24 Is there an accessible route that is stable, firm and slip-resistant? [302.1]</p>	<p><input type="checkbox"/> Yes <input checked="" type="checkbox"/> No</p>		
<p>5.25 Is the route at least 36 inches wide? [403.5.1]</p>	<p><input type="checkbox"/> Yes <input checked="" type="checkbox"/> No</p>		
<p>5.26 Is the running slope no steeper than 1:20, i.e. for every inch of height change there are at least 20 inches of route run? [403.3]</p> <p>Note: If the running slope is steeper than 1:20, treat as a ramp and add features such as edge protection and handrails.</p>	<p><input type="checkbox"/> Yes <input checked="" type="checkbox"/> No</p> <p>Measurement: NA</p>		

ADA Checklist for Existing Facilities - Parks

<p>5.27 Is the cross slope no steeper than 1:48? [403.3]</p>	<p><input type="checkbox"/> Yes <input checked="" type="checkbox"/> No</p> <p>Measurement: NA</p>	
---	--	--

Benches Yes No

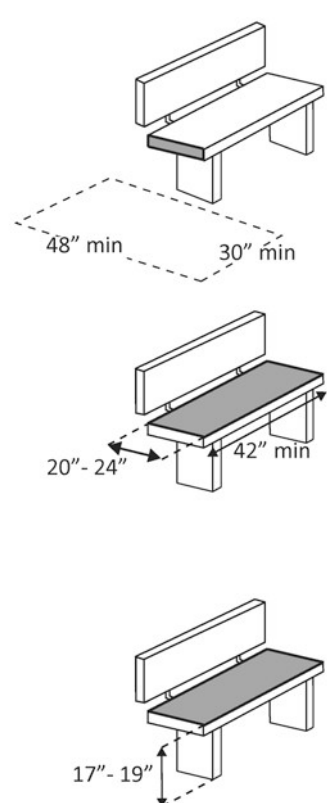
<p>5.28 Is there a clear floor space at least 30 inches wide by at least 48 inches long at the end of the bench and parallel to the short axis of the bench?</p> <p>Is the bench seat at least 42 inches long and no less than 20 inches and no greater than 24 inches deep?</p> <p>Does the bench have back support or is it affixed to a wall?</p> <p>Is the top of the bench seat no less than 17 inches and no greater than 19 inches above the floor? [903]</p>	<p><input checked="" type="checkbox"/> Yes <input type="checkbox"/> No</p> <p>Measurement: 70"</p> <p><input checked="" type="checkbox"/> Yes <input type="checkbox"/> No</p> <p>Measurement: 17"</p>	
---	---	---

Dining Tables Yes No

<p>5.28 Are at least 5 percent, but not less than one, of the dining surfaces for the seating and standing spaces accessible?</p> <p>Is/are the accessible space(s) distributed throughout the facility and located on an accessible route?</p>	<p><input checked="" type="checkbox"/> Yes <input type="checkbox"/> No</p> <p>Total #: 21 Accessible #: 5</p> <p><input checked="" type="checkbox"/> Yes <input type="checkbox"/> No</p>	
--	--	--

ADA Checklist for Existing Facilities - Parks

City of Grand Rapids ADA Transition Plan

Building: Wilcox Park

Location: _____

Date: 10/9/19

Evaluated By: Dom DeGuseppi

Priority 5 - Parks

5.1 Is there at least one route from site arrival points (parking, passenger loading zones, public sidewalks and public transportation stops) that does not require the use of stairs?
[See 2010 ADA Standards for Accessible Design – 206.2.1]

Yes No

If yes, location of route:

Parking Yes No

5.2 If parking is provided for the public, are an adequate number of accessible spaces provided? [208.2]	<input type="checkbox"/> Yes <input checked="" type="checkbox"/> No Total #: Accessible #:	Total Spaces	Accessible Spaces	Gravel Lot
		1 - 25	1	
		26 - 50	2	
		51 - 75	3	
		76 - 100	4	
		100+ see 2010 Standards 208.2		



5.3 Are accessible spaces at least 8 feet wide with an access aisle at least 8 feet wide?
[502.2, 502.3]

Yes No

Measurement:

Note: Two spaces may share an access aisle. Check state/local requirements;

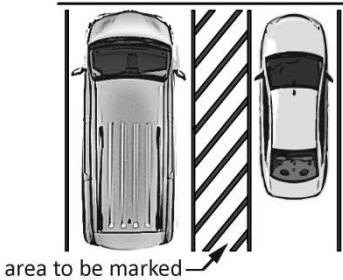
ADA Checklist for Existing Facilities - Parks

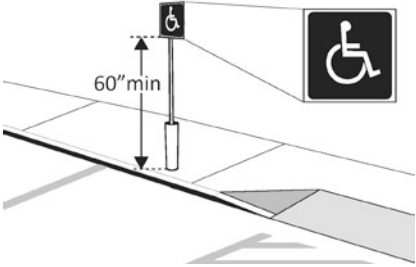
	some specify that each space have its own aisle.			
5.4	<p>Are the access aisles marked with signage and surface painting so as to discourage parking in them? [502.3.3]</p> <p>Note: The marking method and color may be addressed by state/local requirements.</p>	<input type="checkbox"/> Yes <input checked="" type="checkbox"/> No		
5.5	<p>Is the slope of the accessible parking spaces and access aisles no steeper than 1:48 in all directions? [502.4]</p>	<input type="checkbox"/> Yes <input checked="" type="checkbox"/> No Measurement:		
5.6	<p>Do the access aisles adjoin an accessible route? [502.3]</p>	<input type="checkbox"/> Yes <input checked="" type="checkbox"/> No		
5.7	<p>Are accessible spaces identified with a sign that includes the International Symbol of Accessibility? Is the bottom of the sign at least 60 inches and not greater than 66 inches above the ground? [502.6]</p>	<input type="checkbox"/> Yes <input checked="" type="checkbox"/> No <input type="checkbox"/> Yes <input checked="" type="checkbox"/> No Measurement:		
5.8	<p>Of the total parking spaces, are the accessible spaces located on the closest accessible route to the accessible entrance(s)? [208.3.1]</p>	<input type="checkbox"/> Yes <input checked="" type="checkbox"/> No		

Exterior Accessible Route

5.9 Is the route stable, firm and slip-resistant?
[302.1] Yes No

5.10 Is the route at least 36 inches wide?
[403.5.1] Yes No

Measurement:

Note: The accessible route can narrow to 32 inches min. for a max. of 24 inches. These narrower portions of the route must be at least 48 inches from each other.

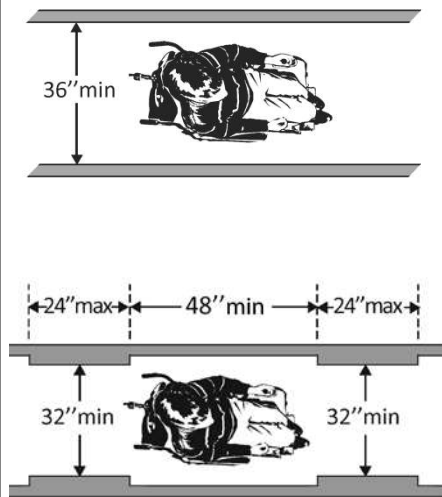

5.11 If the route is greater than 200 feet in length and less than 60 inches wide, is there a passing space no less than 60 x 60 inches?
[403.5.3] Yes No

Measurement:

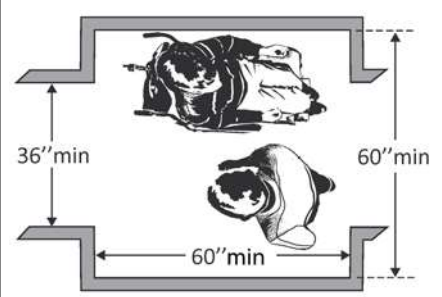

5.12 If there are grates or openings on the route, are the openings no larger than 1/2 inches?
[403.5.3]

If the route is greater than 200 feet in length and less than 60 inches wide, is there a passing space no less than 60 x 60 inches?
[403.5.3]

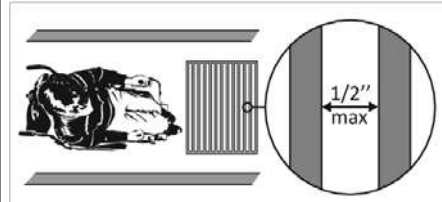

ADA Checklist for Existing Facilities - Parks

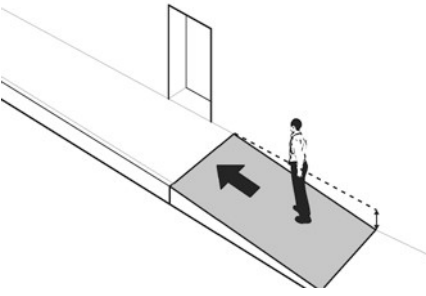
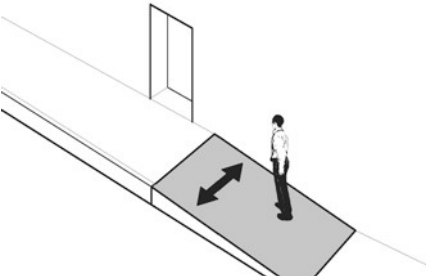
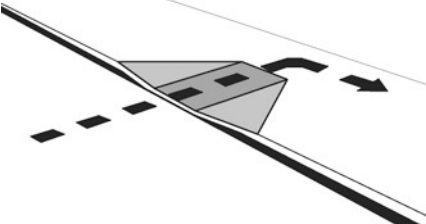
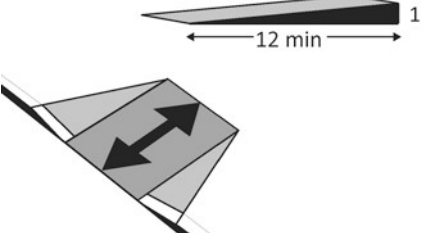
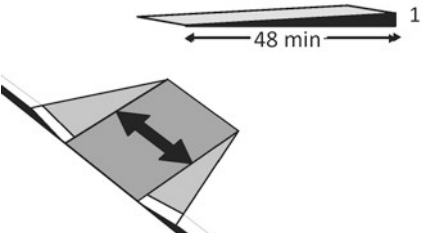
<p>5.13 Is the running slope no steeper than 1:20, i.e. for every inch of height change there are at least 20 inches of route run? [403.3]</p> <p>Note: If the running slope is steeper than 1:20, treat as a ramp and add features such as edge protection and handrails.</p>	<p><input type="checkbox"/> Yes <input checked="" type="checkbox"/> No</p> <p>Measurement:</p>		
<p>5.14 Is the cross slope no steeper than 1:48? [403.3]</p>	<p><input type="checkbox"/> Yes <input checked="" type="checkbox"/> No</p> <p>Measurement:</p>		
<p>Curb Ramps <input type="checkbox"/> Yes <input checked="" type="checkbox"/> No</p>			
<p>5.15 If the accessible route crosses a curb, is there a curb ramp? [402.2]</p>	<p><input type="checkbox"/> Yes <input checked="" type="checkbox"/> No</p>		
<p>5.16 Is the running slope of the curb ramp no steeper than 1:12, i.e. for every inch of height change there are at least 12 inches of curb ramp run? [406.1, 405.2]</p>	<p><input type="checkbox"/> Yes <input checked="" type="checkbox"/> No</p> <p>Measurement:</p>		
<p>5.17 Is the cross slope of the curb ramp, excluding flares, no steeper than 1:48? [406.1, 405.3]</p>	<p><input type="checkbox"/> Yes <input checked="" type="checkbox"/> No</p> <p>Measurement:</p>		

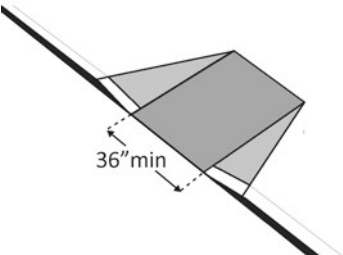
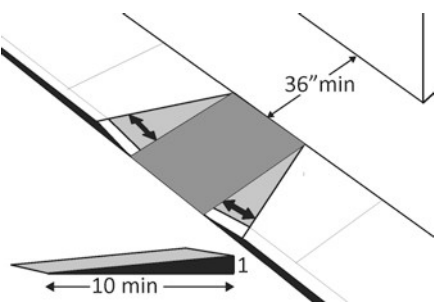
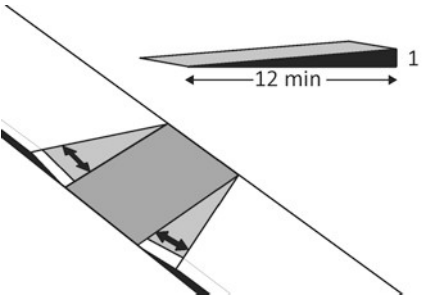
<p>5.18 Is the curb ramp, excluding flares, at least 36 inches wide? [406.1, 405.5]</p>	<p><input type="checkbox"/> Yes <input checked="" type="checkbox"/> No</p> <p>Measurement:</p>		
<p>5.19 At the top of the curb ramp is there a level landing (slope no steeper than 1:48 in all directions) that is at least 36 inches long and at least as wide as the curb ramp? [406.4]</p> <p>If there are curb ramp flares, are the slopes of the flares no steeper than 1:10, i.e. for every inch of height change there are at least 10 inches of flare run? [406.3]</p>	<p><input type="checkbox"/> Yes <input checked="" type="checkbox"/> No</p> <p>Measurement:</p> <p><input type="checkbox"/> Yes <input checked="" type="checkbox"/> No</p> <p>Measurement:</p>		
<p>5.20 If the landing at the top is less than 36 inches long, are there curb ramp flares? [406.4]</p> <p>Are the slopes of the flares no greater than 1:12, i.e. for every inch of height change there are at least 12 inches of flare run? [406.4]</p>	<p><input type="checkbox"/> Yes <input checked="" type="checkbox"/> No</p> <p><input type="checkbox"/> Yes <input checked="" type="checkbox"/> No</p> <p>Measurement:</p>		
<p>Accessible Play Components <input type="checkbox"/> Yes <input checked="" type="checkbox"/> No</p>			
<p>5.21 <u>Ground Level Play Components</u> Is there an accessible route to at least one of each type of ground level play component?</p> <p>Notes:</p> <ol style="list-style-type: none"> 1. A play component is an element designed to generate play, socialization and learning. 2. Ground level play components are components that can be approached and exited at 	<p><input type="checkbox"/> Yes <input type="checkbox"/> No</p>		

ADA Checklist for Existing Facilities - Parks

<p>ground level. Examples include rockers, swings, diggers and stand-alone slides.</p>			
<p>5.22 <u>Elevated Play Components</u> Are there any accessible elevated play components? If so, is there an accessible route to the components?</p>	<p><input type="checkbox"/> Yes <input type="checkbox"/> No <input type="checkbox"/> Yes <input type="checkbox"/> No</p>		
<p>5.23 Is the vertical clearance of the accessible route at least 80 inches above the ground surface? Note: Objects below 80 inches may not protrude into the accessible route.</p>	<p><input type="checkbox"/> Yes <input type="checkbox"/> No</p>		
<p>Pavilion <input type="checkbox"/> Yes <input checked="" type="checkbox"/> No</p>			
<p>5.24 Is there an accessible route that is stable, firm and slip-resistant? [302.1]</p>	<p><input type="checkbox"/> Yes <input type="checkbox"/> No</p>		
<p>5.25 Is the route at least 36 inches wide? [403.5.1]</p>	<p><input type="checkbox"/> Yes <input type="checkbox"/> No</p>		
<p>5.26 Is the running slope no steeper than 1:20, i.e. for every inch of height change there are at least 20 inches of route run? [403.3] Note: If the running slope is steeper than 1:20, treat as a ramp and add features such as edge protection and handrails.</p>	<p><input type="checkbox"/> Yes <input type="checkbox"/> No Measurement:</p>		

ADA Checklist for Existing Facilities - Parks

<p>5.27 Is the cross slope no steeper than 1:48? [403.3]</p>	<p><input type="checkbox"/> Yes <input type="checkbox"/> No</p> <p>Measurement:</p>	
---	---	--

Benches Yes No

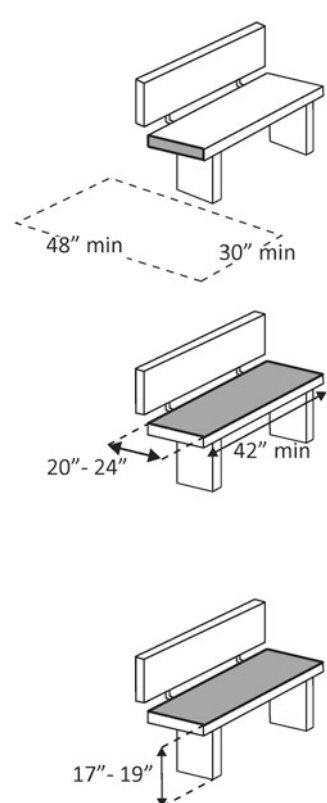
<p>5.28 Is there a clear floor space at least 30 inches wide by at least 48 inches long at the end of the bench and parallel to the short axis of the bench?</p> <p>Is the bench seat at least 42 inches long and no less than 20 inches and no greater than 24 inches deep?</p> <p>Does the bench have back support or is it affixed to a wall?</p> <p>Is the top of the bench seat no less than 17 inches and no greater than 19 inches above the floor? [903]</p>	<p><input type="checkbox"/> Yes <input type="checkbox"/> No</p> <p>Measurement:</p> <p><input type="checkbox"/> Yes <input type="checkbox"/> No</p> <p>Measurement:</p> <p><input type="checkbox"/> Yes <input type="checkbox"/> No</p> <p><input type="checkbox"/> Yes <input type="checkbox"/> No</p> <p>Measurement:</p>	
---	---	---

Dining Tables Yes No

<p>5.28 Are at least 5 percent, but not less than one, of the dining surfaces for the seating and standing spaces accessible?</p> <p>Is/are the accessible space(s) distributed throughout the facility and located on an accessible route?</p>	<p><input type="checkbox"/> Yes <input checked="" type="checkbox"/> No</p> <p>Total #: 2 Accessible #: 0</p> <p><input type="checkbox"/> Yes <input checked="" type="checkbox"/> No</p>	
--	---	--

ADA Checklist for Existing Facilities - Parks

City of Grand Rapids ADA Transition Plan

Building: Willow Park

Location: Willow Lane

Date: 10/1/19

Evaluated By: Dom DeGuseppi

Priority 5 - Parks

5.1 Is there at least one route from site arrival points (parking, passenger loading zones, public sidewalks and public transportation stops) that does not require the use of stairs? [See 2010 ADA Standards for Accessible Design – 206.2.1]

Yes No

If yes, location of route:

Parking Yes No

5.2 If parking is provided for the public, are an adequate number of accessible spaces provided? [208.2]	<input type="checkbox"/> Yes <input checked="" type="checkbox"/> No Total #: Accessible #:	Total Spaces	Accessible Spaces	Street parking
		1 - 25	1	
		26 - 50	2	
		51 - 75	3	
		76 - 100	4	
		100+ see 2010 Standards 208.2		



5.3 Are accessible spaces at least 8 feet wide with an access aisle at least 8 feet wide? [502.2, 502.3]

Yes No

Measurement:

Note: Two spaces may share an access aisle. Check state/local requirements;

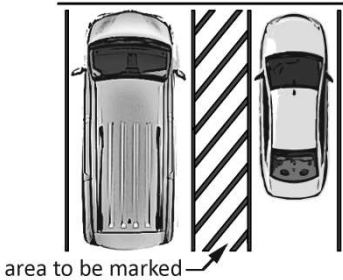
ADA Checklist for Existing Facilities - Parks

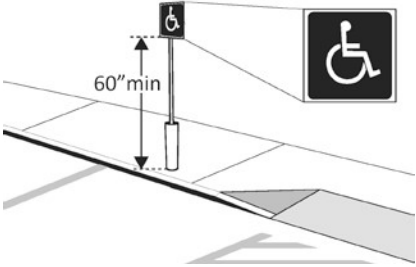
	some specify that each space have its own aisle.		
<p>5.4 Are the access aisles marked with signage and surface painting so as to discourage parking in them? [502.3.3]</p> <p>Note: The marking method and color may be addressed by state/local requirements.</p>	<p><input type="checkbox"/> Yes <input checked="" type="checkbox"/> No</p>		
<p>5.5 Is the slope of the accessible parking spaces and access aisles no steeper than 1:48 in all directions? [502.4]</p>	<p><input type="checkbox"/> Yes <input checked="" type="checkbox"/> No</p> <p>Measurement: NA</p>		
<p>5.6 Do the access aisles adjoin an accessible route? [502.3]</p>	<p><input type="checkbox"/> Yes <input checked="" type="checkbox"/> No</p>		
<p>5.7 Are accessible spaces identified with a sign that includes the International Symbol of Accessibility?</p> <p>Is the bottom of the sign at least 60 inches and not greater than 66 inches above the ground? [502.6]</p>	<p><input type="checkbox"/> Yes <input checked="" type="checkbox"/> No</p> <p><input type="checkbox"/> Yes <input checked="" type="checkbox"/> No</p> <p>Measurement:</p>		
<p>5.8 Of the total parking spaces, are the accessible spaces located on the closest accessible route to the accessible entrance(s)? [208.3.1]</p>	<p><input type="checkbox"/> Yes <input checked="" type="checkbox"/> No</p>		

Exterior Accessible Route

5.9 Is the route stable, firm and slip-resistant?
[302.1] Yes No

5.10 Is the route at least 36 inches wide?
[403.5.1] Yes No

Measurement:

Note: The accessible route can narrow to 32 inches min. for a max. of 24 inches. These narrower portions of the route must be at least 48 inches from each other.

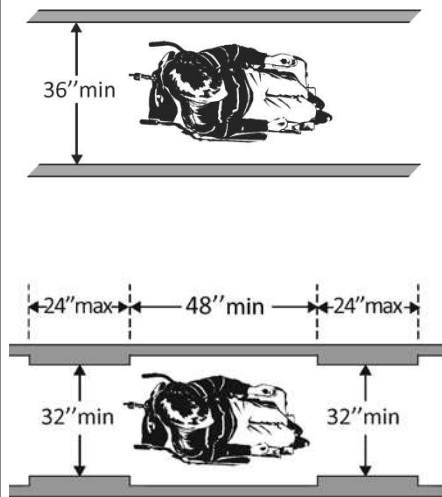

5.11 If the route is greater than 200 feet in length and less than 60 inches wide, is there a passing space no less than 60 x 60 inches?
[403.5.3] Yes No

Measurement:

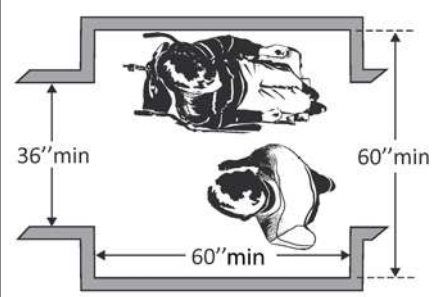

5.12 If there are grates or openings on the route, are the openings no larger than 1/2 inches?
[403.5.3]

If the route is greater than 200 feet in length and less than 60 inches wide, is there a passing space no less than 60 x 60 inches?
[403.5.3]

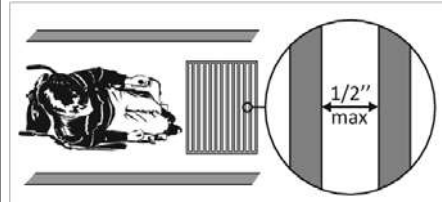

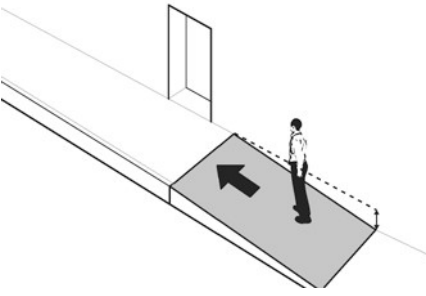
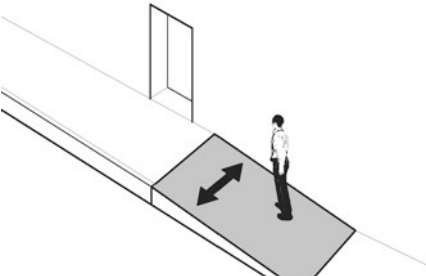
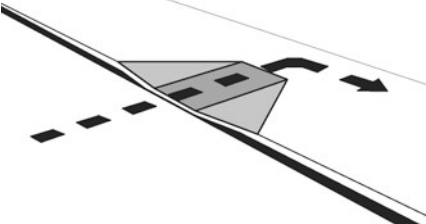
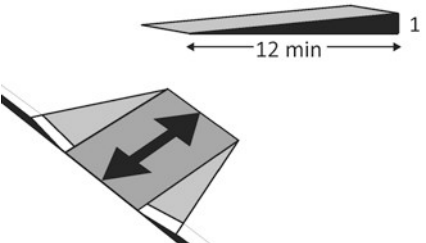
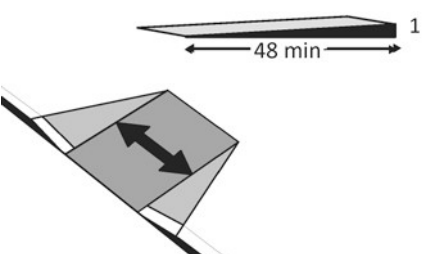
<p>5.13 Is the running slope no steeper than 1:20, i.e. for every inch of height change there are at least 20 inches of route run? [403.3]</p> <p>Note: If the running slope is steeper than 1:20, treat as a ramp and add features such as edge protection and handrails.</p>	<p><input type="checkbox"/> Yes <input checked="" type="checkbox"/> No</p> <p>Measurement:</p>		
<p>5.14 Is the cross slope no steeper than 1:48? [403.3]</p>	<p><input type="checkbox"/> Yes <input checked="" type="checkbox"/> No</p> <p>Measurement:</p>		
<p>Curb Ramps <input type="checkbox"/> Yes <input checked="" type="checkbox"/> No</p>			
<p>5.15 If the accessible route crosses a curb, is there a curb ramp? [402.2]</p>	<p><input type="checkbox"/> Yes <input type="checkbox"/> No</p>		
<p>5.16 Is the running slope of the curb ramp no steeper than 1:12, i.e. for every inch of height change there are at least 12 inches of curb ramp run? [406.1, 405.2]</p>	<p><input type="checkbox"/> Yes <input type="checkbox"/> No</p> <p>Measurement:</p>		
<p>5.17 Is the cross slope of the curb ramp, excluding flares, no steeper than 1:48? [406.1, 405.3]</p>	<p><input type="checkbox"/> Yes <input type="checkbox"/> No</p> <p>Measurement:</p>		

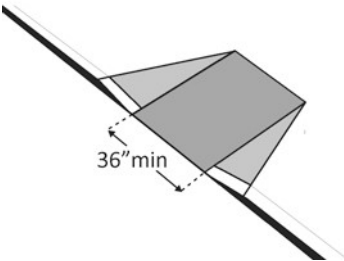
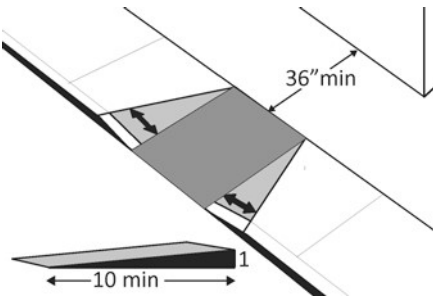
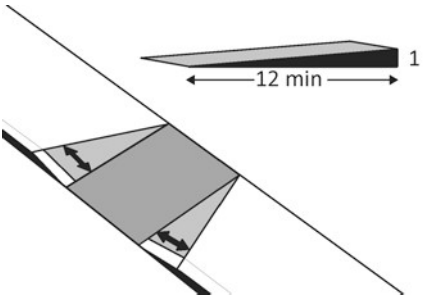
<p>5.18 Is the curb ramp, excluding flares, at least 36 inches wide? [406.1, 405.5]</p>	<p><input type="checkbox"/> Yes <input type="checkbox"/> No</p> <p>Measurement:</p>		
<p>5.19 At the top of the curb ramp is there a level landing (slope no steeper than 1:48 in all directions) that is at least 36 inches long and at least as wide as the curb ramp? [406.4]</p> <p>If there are curb ramp flares, are the slopes of the flares no steeper than 1:10, i.e. for every inch of height change there are at least 10 inches of flare run? [406.3]</p>	<p><input type="checkbox"/> Yes <input type="checkbox"/> No</p> <p>Measurement:</p> <p><input type="checkbox"/> Yes <input type="checkbox"/> No</p> <p>Measurement:</p>		
<p>5.20 If the landing at the top is less than 36 inches long, are there curb ramp flares? [406.4]</p> <p>Are the slopes of the flares no greater than 1:12, i.e. for every inch of height change there are at least 12 inches of flare run? [406.4]</p>	<p><input type="checkbox"/> Yes <input type="checkbox"/> No</p> <p><input type="checkbox"/> Yes <input type="checkbox"/> No</p> <p>Measurement:</p>		
<p>Accessible Play Components <input checked="" type="checkbox"/> Yes <input type="checkbox"/> No</p>			
<p>5.21 <u>Ground Level Play Components</u> Is there an accessible route to at least one of each type of ground level play component?</p> <p>Notes:</p> <ol style="list-style-type: none"> 1. A play component is an element designed to generate play, socialization and learning. 2. Ground level play components are components that can be approached and exited at 	<p><input checked="" type="checkbox"/> Yes <input type="checkbox"/> No</p>		

ADA Checklist for Existing Facilities - Parks

<p>ground level. Examples include rockers, swings, diggers and stand-alone slides.</p>			
<p>5.22 <u>Elevated Play Components</u> Are there any accessible elevated play components?</p> <p>If so, is there an accessible route to the components?</p>	<p><input type="checkbox"/> Yes <input checked="" type="checkbox"/> No</p> <p><input type="checkbox"/> Yes <input checked="" type="checkbox"/> No</p>		
<p>5.23 Is the vertical clearance of the accessible route at least 80 inches above the ground surface?</p> <p>Note: Objects below 80 inches may not protrude into the accessible route.</p>	<p><input type="checkbox"/> Yes <input type="checkbox"/> No</p>		NA
<p>Pavilion <input type="checkbox"/> Yes <input checked="" type="checkbox"/> No</p>			
<p>5.24 Is there an accessible route that is stable, firm and slip-resistant? [302.1]</p>	<p><input type="checkbox"/> Yes <input type="checkbox"/> No</p>		
<p>5.25 Is the route at least 36 inches wide? [403.5.1]</p>	<p><input type="checkbox"/> Yes <input type="checkbox"/> No</p>		
<p>5.26 Is the running slope no steeper than 1:20, i.e. for every inch of height change there are at least 20 inches of route run? [403.3]</p> <p>Note: If the running slope is steeper than 1:20, treat as a ramp and add features such as edge protection and handrails.</p>	<p><input type="checkbox"/> Yes <input type="checkbox"/> No</p> <p>Measurement:</p>		

ADA Checklist for Existing Facilities - Parks

<p>5.27 Is the cross slope no steeper than 1:48? [403.3]</p>	<p><input type="checkbox"/> Yes <input type="checkbox"/> No</p> <p>Measurement:</p>	
---	---	--

Benches Yes No

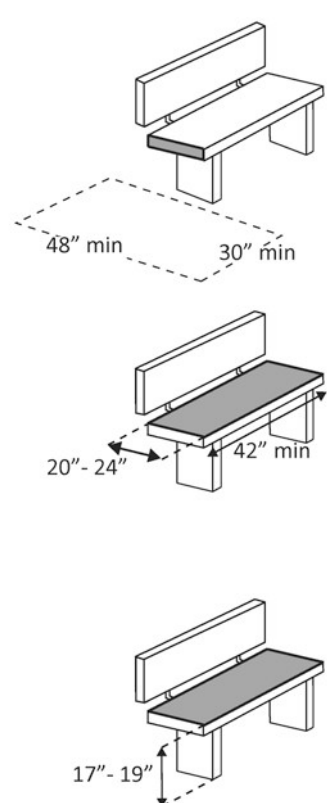
<p>5.28 Is there a clear floor space at least 30 inches wide by at least 48 inches long at the end of the bench and parallel to the short axis of the bench?</p> <p>Is the bench seat at least 42 inches long and no less than 20 inches and no greater than 24 inches deep?</p> <p>Does the bench have back support or is it affixed to a wall?</p> <p>Is the top of the bench seat no less than 17 inches and no greater than 19 inches above the floor? [903]</p>	<p><input type="checkbox"/> Yes <input type="checkbox"/> No</p> <p>Measurement:</p> <p><input type="checkbox"/> Yes <input type="checkbox"/> No</p> <p>Measurement:</p> <p><input type="checkbox"/> Yes <input type="checkbox"/> No</p> <p><input type="checkbox"/> Yes <input type="checkbox"/> No</p> <p>Measurement:</p>	 <p>The diagrams illustrate the ADA requirements for benches. The first diagram shows a top-down view of a bench with a dashed rectangle indicating a clear floor space of at least 48 inches by 30 inches at the end of the bench. The second diagram shows a side view of a bench with a seat length of at least 42 inches and a seat depth between 20 and 24 inches. The third diagram shows a side view of a bench with a seat height between 17 and 19 inches from the floor.</p>
---	---	---

Dining Tables Yes No

<p>5.28 Are at least 5 percent, but not less than one, of the dining surfaces for the seating and standing spaces accessible?</p> <p>Is/are the accessible space(s) distributed throughout the facility and located on an accessible route?</p>	<p><input checked="" type="checkbox"/> Yes <input type="checkbox"/> No</p> <p>Total #: 2 Accessible #: 1</p> <p><input type="checkbox"/> Yes <input checked="" type="checkbox"/> No</p>	
--	---	--