



CONSTRUCTING SAFE GUARDRAILS

City of Grand Rapids
Building Safety Division

218-326-7601

www.cityofgrandrapidsmn.com

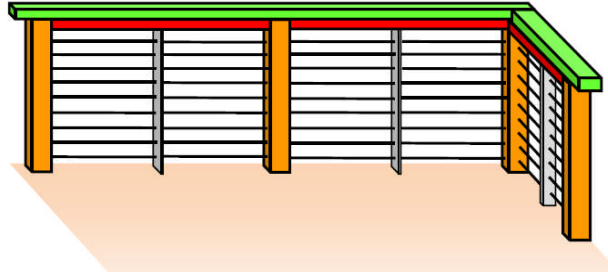

The purpose of this handout is to provide illustrations of common guardrail construction techniques. It is not the purpose of this handout to endorse any of the methods shown or limit designs to those shown here. The techniques shown may not be suitable for some designs, soil types, or locations. While every attempt has been made to insure the correctness of this handout, no guarantees are made to its accuracy or completeness. Responsibility for compliance with applicable codes and ordinances falls on the owner or contractor. For specific questions regarding code requirements, refer to the Minnesota State Building Code or contact your local Building Safety Division.

BUILD IT RIGHT!

Installation of secure guards is critical to improving the safety of decks, especially those constructed more than four or five feet above ground. Recent studies show that historic installation details fail to meet design load requirements. It is therefore necessary that sturdier attachment methods be used to prevent failure of the guard. What is often forgotten when a new deck is constructed is that, over time, the components of guards loosen, deteriorate due to the effects of weather, and frequently don't get the maintenance they deserve resulting in older guards falling far short of minimum standards for safety. The goal of this handout is to identify various construction techniques that have been shown to provide a greater degree of safety both at the time of construction and during the life of the deck. The old methods of constructing guards is no longer acceptable.

POST CONNECTIONS

Studies have shown that one of the most vulnerable details of guard construction is the connection of the guard post to the deck.

A common method of attaching the guard post to the rim joist is to notch the guard post and use through bolts or lag bolts as fasteners. Tests have shown that notched guard posts fail to meet the 200 pound horizontal load required by the Minnesota Residential Code. The following illustrations show how notched posts fail.

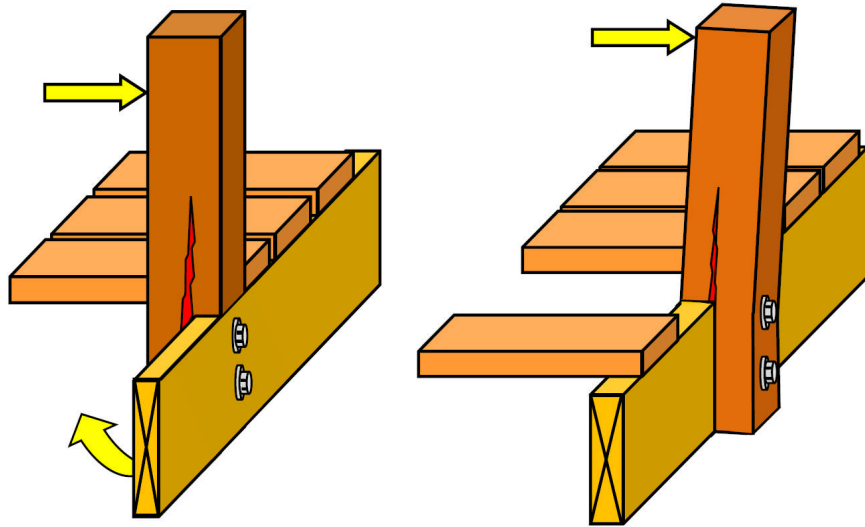

Following are several illustrations detailing deck rail post attachments that provide a more secure attachment. Hold down anchors are used to provide the necessary rigidity to the post attachment.

DECK RAIL POST ATTACHED TO RIM JOIST

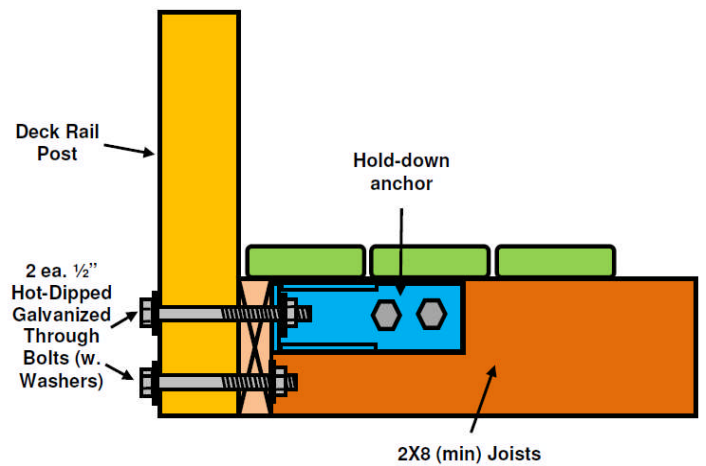
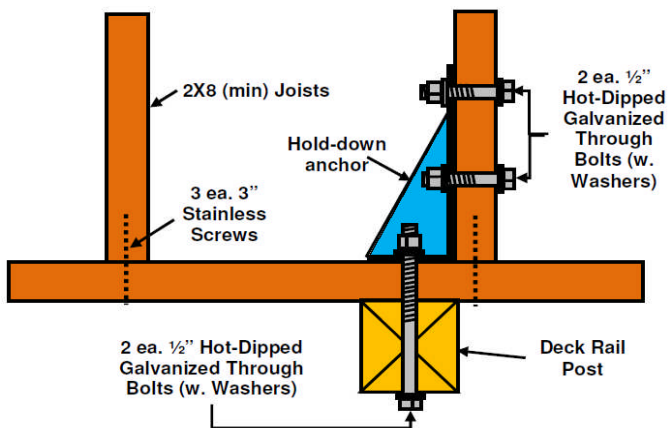

BOLTING PATTERN

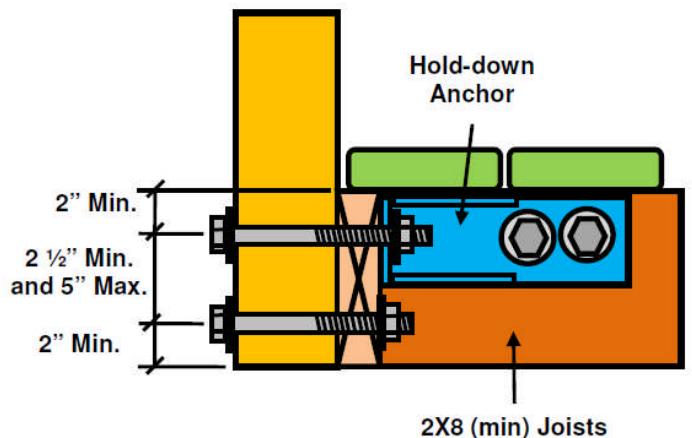
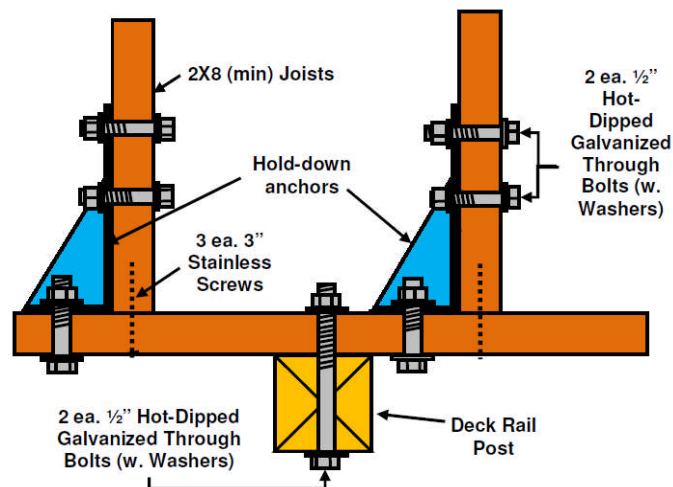

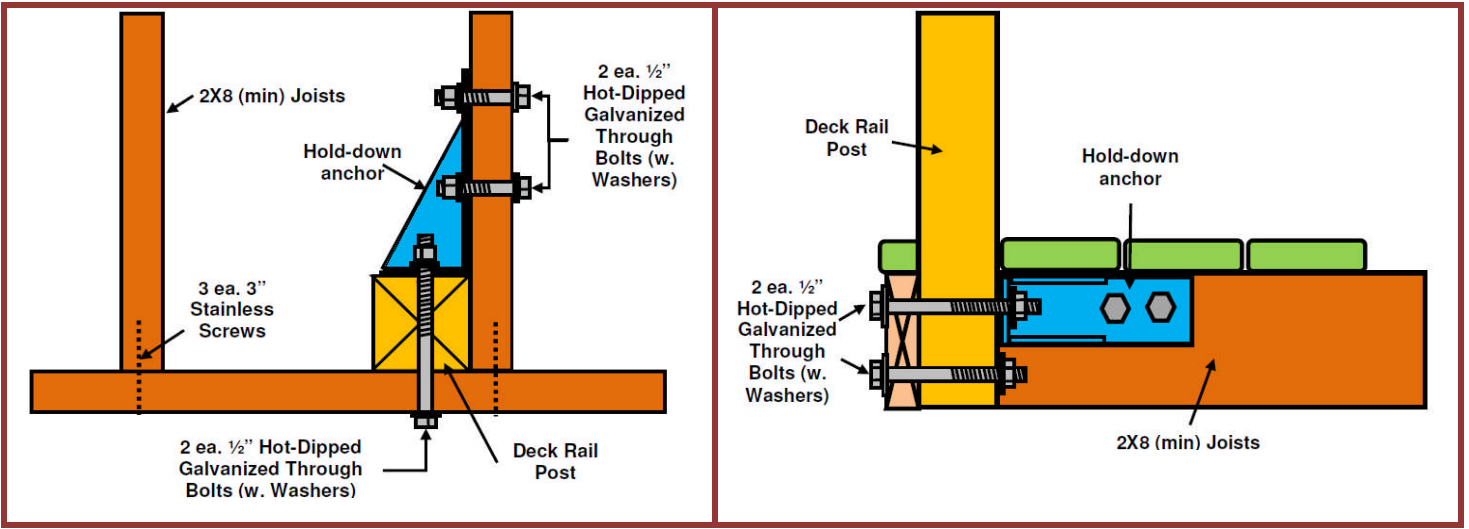

DECK RAIL POST ATTACHED TO SIDE JOIST

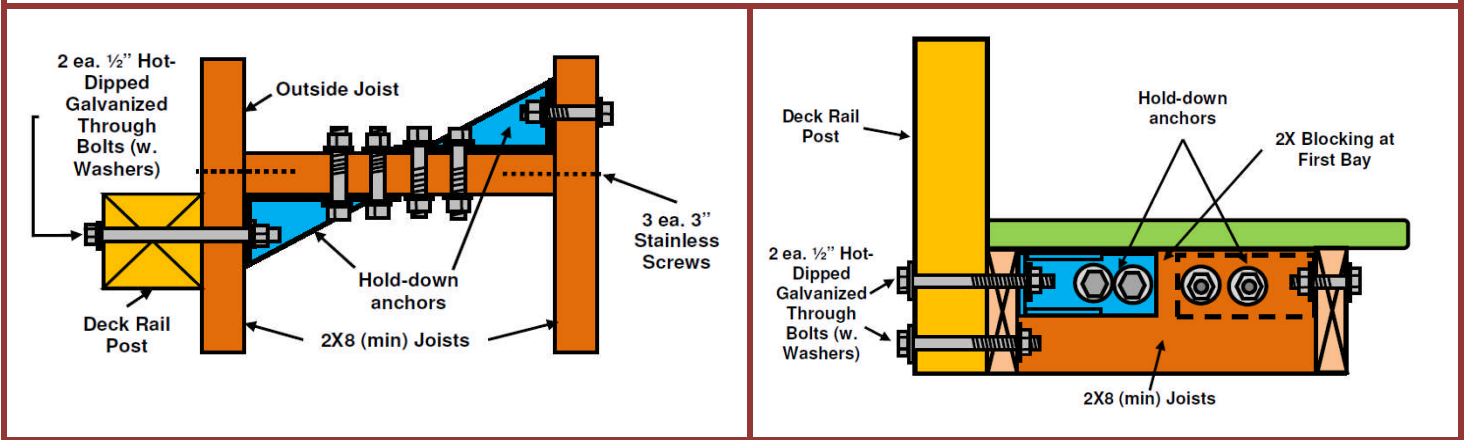

Another method shown below involves attachment of the deck rail post to both joists and the beam creating a more secure attachment spread over a greater length of the post.

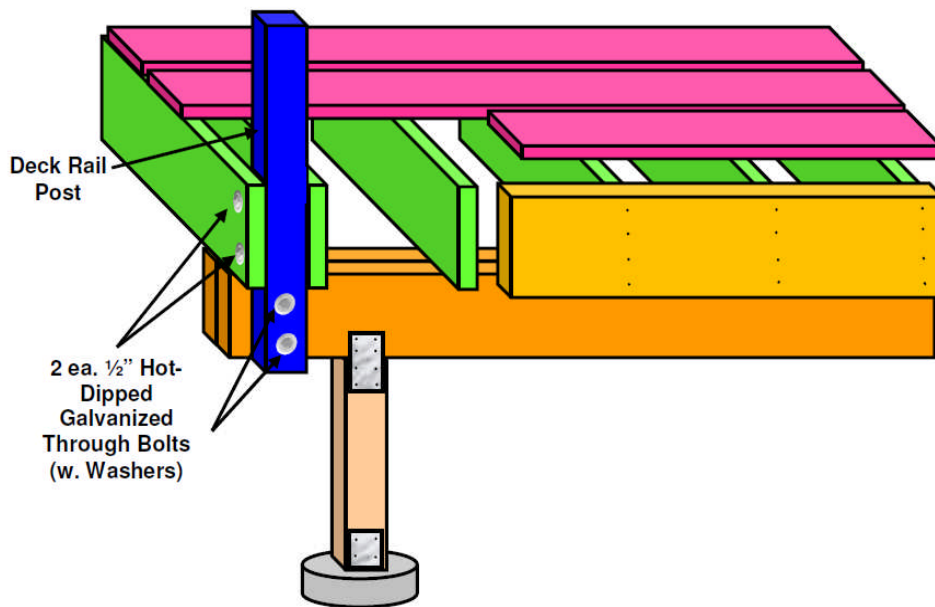

Yet another method sandwiches the deck rail post between two rim joists. Note that additional blocking must be installed to resist the rotational forces on the rim

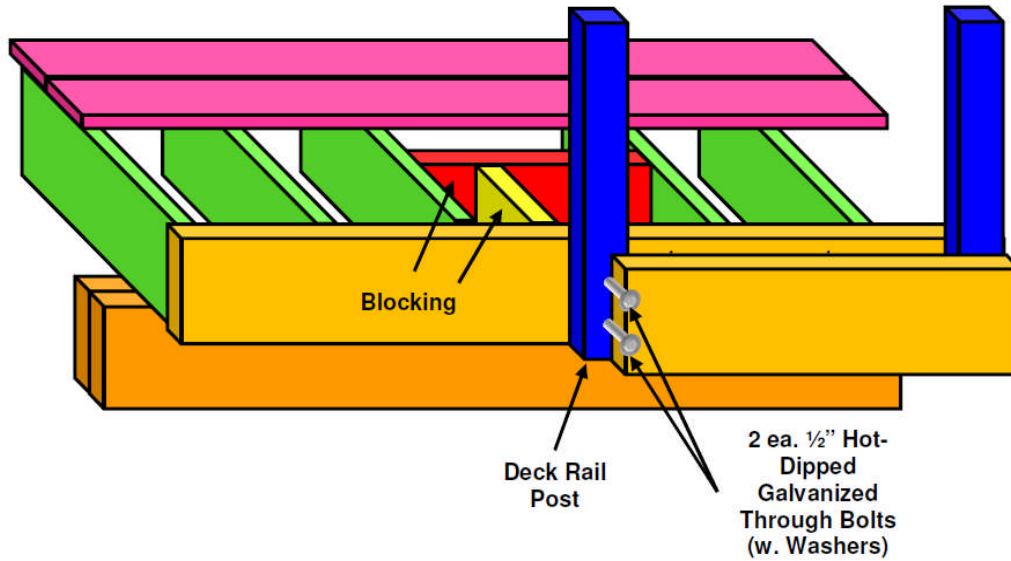

Connection of railing components should avoid the use of fasteners such as toenails or nails that are subject to withdrawal. Metal connectors using lag bolts provide secure attachments.

Examples of Devices that can be used to resist horizontal loads

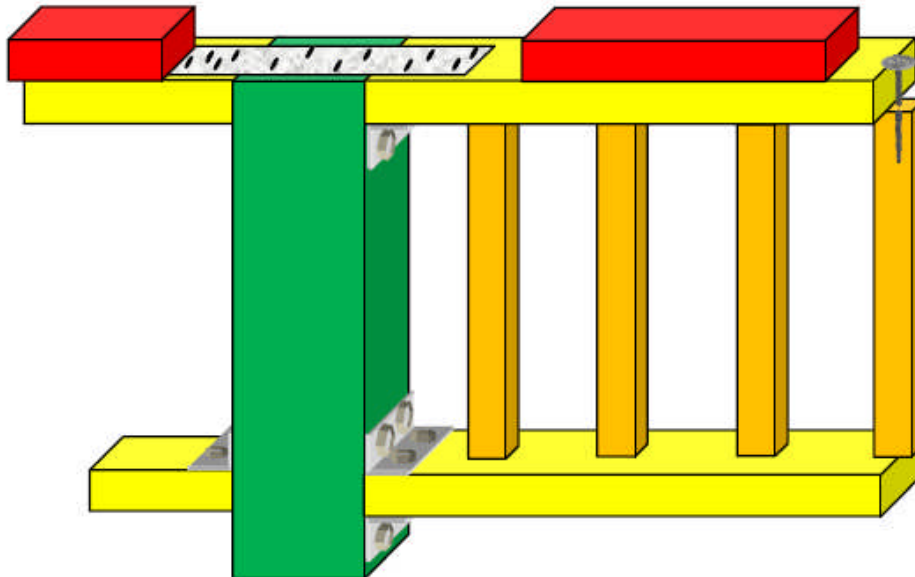

RAILINGS USING TEMPERED GLASS

If you plan to use tempered glass in your guardrails, you will be required to provide written evidence of compliance with the Minnesota Building Code in the form of an ICC Evaluation Report or a plan prepared by an architect licensed in Minnesota.

CABLE RAILINGS

Cable railings are becoming more popular, but require special attention given to the connections, for them to meet code requirements. Cables that are not taut enough will result in openings that exceed the 4 inch diameter sphere test. Cables must be stainless steel and at least 1/8 inch diameter. Spacing of cables should not exceed 3 1/2 inches. A rail with 9 cables each exerting 300 pounds of tension will exert roughly 2700 pounds of pull on end posts making the connections of the ends of the posts critical. Posts used for cable rails must be wood, steel or aluminum. Wood posts must be not less than 4X4. Steel and aluminum posts must be designed for the anticipated stresses. Posts made of plastics, composites, or other similar materials are not permitted unless specifically approved by the manufacturer. Spacing of cable supports is dependent on the size of the cable. The heavier the cable, the further apart supports may be. There are many types of cable connectors that will work depending on what look you are trying to achieve. Following are a number of illustrations that provide acceptable construction practices.

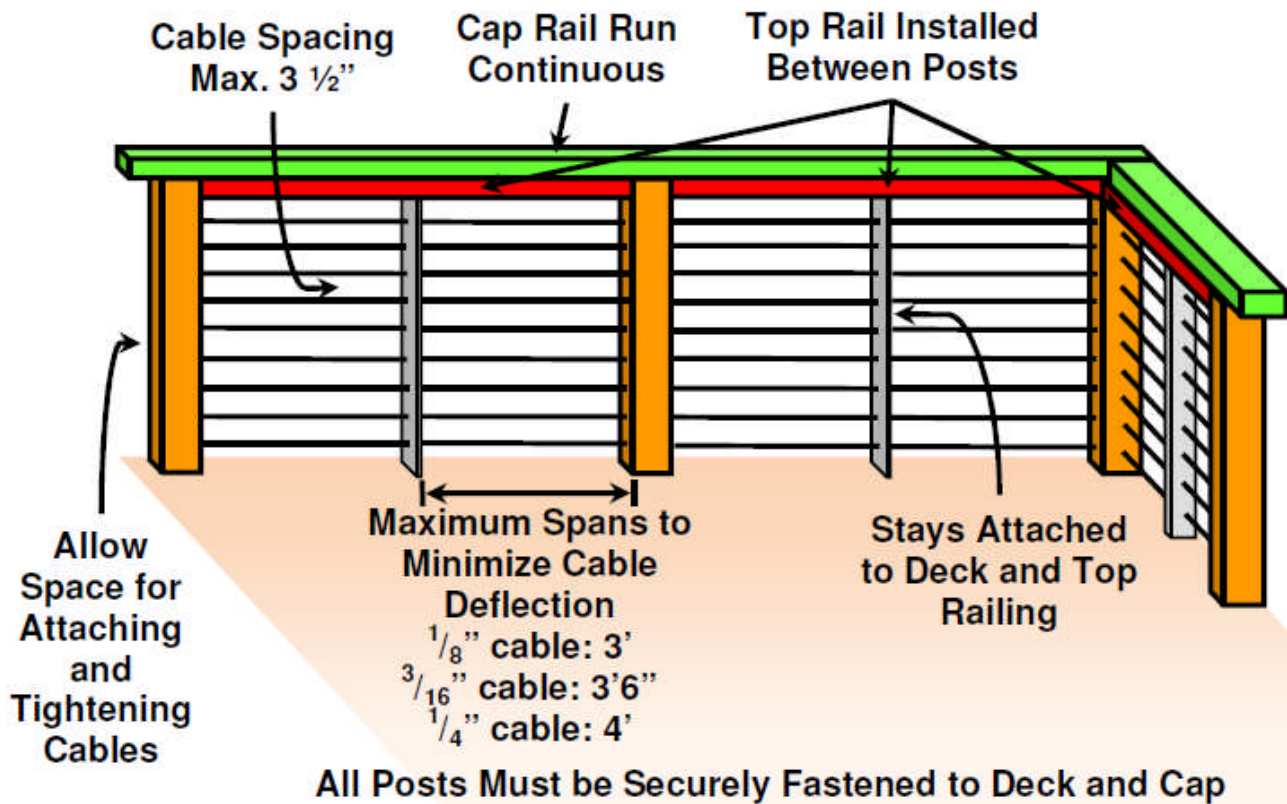

CABLE TERMINATION

