



CITY OF GRAND RAPIDS

CITY COUNCIL
CHAMBERS
420 NORTH POKEGAMA
AVE.

Meeting Agenda Full Detail City Council

Monday, April 11, 2011

5:00 PM

City Hall Council Chambers

5:00 **CALL TO ORDER: Pursuant to due notice and call thereof a Regular Meeting of the**
p.m. **Grand Rapids City Council will be held on Monday, April 11, 2011 at 5:00 p.m. in**
 Council Chambers, 420 North Pokegama Avenue, Grand Rapids, Minnesota.

5:01 **CALL OF ROLL**
p.m.

5:02 **MEETING PROTOCOL POLICY**
p.m.

Please be aware that the Council has adopted a Meeting Protocol Policy which informs attendees of the Council's desire to conduct meetings in an orderly manner which welcomes all civil input from citizens and interested parties. If you are unaware of the policy, copies (orange color) are available in the wall file by the Council entrance.

5:03 **PUBLIC FORUM**
p.m.

5:08 **COUNCIL REPORTS**
p.m.

5:10 **APPROVAL OF MINUTES**
p.m.

11-1447 Approve minutes for Monday, March 28, 2011 at 4:00 p.m. and 5:00 p.m. Worksession and Regular meetings.

Attachments: [March 28, 2011 Worksession](#)
 [March 28, 2011 Regular Meeting](#)

5:11 **CONSENT AGENDA**
p.m.

Any item on the consent agenda shall be removed for consideration by request of any one Councilmember, City staff, or the public and put on the regular agenda for discussion and consideration.

1. **11-1427** Request by the Police Department to hold an auction and sell impounded vehicles.

2. **11-1438** A resolution approving the plans and specifications and the advertisement of bids for CP 2009-11B, Riverfront Energy Center.

Attachments: [4-11-11 RESOL CP 2009-11B Ordering Advertisement.pdf](#)

3. **11-1441** Approve the hiring of the employees listed with the Grand Rapids Park and Recreation Department.
4. **11-1442** Donation from the Grand Rapids Jaycees
Attachments: [Jaycees Donation Resolution](#)
5. **11-1443** Consider the donation of old computers to PCs for People.
Attachments: [PCs for People Articles of Incorporation.pdf](#)
[Computer Donation List 2011.pdf](#)
6. **11-1450** Consider approving the annual renewal of the license for the Capital Planning Software Planlt.
7. **11-1445** Consider adopting a resolution approving amendments to the Economic Development Revenue Notes for Northland Counseling Center Project, Series 2002A and 2002B and related documents.
Attachments: [Economic Development Rev Notes-Northland Counseling](#)
8. **11-1446** Consider adopting a resolution authorizing an \$18,309 transfer from the General Fund to the Grand Rapids Public Library Fund for the 2010 Minimum Local Support Requirement.
Attachments: [Library operating transfer \\$18,309 for 2010](#)
[Letter from Arrowhead Library System](#)

5:13 SETTING OF REGULAR AGENDA
p.m.

This is an opportunity to approve the regular agenda as presented or add/delete by a majority vote of the Council members present an agenda item.

5:14 ACKNOWLEDGE BOARDS & COMMISSIONS
p.m.

9. **11-1448** Acknowledge minutes for Boards & Commissions.
Attachments: [February 23, 2011 Human Rights Commission](#)
[February 24, 2011 GREDA](#)
[March 10, 2011 GREDA](#)

5:15 DEPARTMENT HEAD REPORT
p.m.

10. **11-1451** Finance Department - Shirley Miller

5:25 COMMUNITY DEVELOPMENT
p.m.

11. **11-1444** Reconvene consideration of the recommendation of the Planning Commission to adopt an Ordinance amending Section 30-512 Table-1 (Permitted Uses) of the Land Development Regulations that would add Recycling Center uses, as a permitted use, within the PU/SPU (Public Use/Shoreland Public Use) zoning district, and authorize its publication in summary form.

Attachments: [Recycling Center Use in PU Text Amendment Ordinance 3-28-11](#)
[City Zoning Map](#)
[FLU Map Final Draft-PUC Site](#)
[March 28 2011 CC Regular Meeting](#)
[Rezoning Considerations](#)

5:45 POLICE DEPARTMENT
p.m.

12. **11-1429** Request by the Grand Rapids Police Department to trade radios from the old radio system to Hibbing Community College in exchange for a reduced cost to our training they charge us.

Recess regular meeting for public hearings scheduled to begin at 6:00
p.m.

6:00 PUBLIC HEARINGS
p.m.

13. **11-1439** Conduct a public hearing to receive public input on granting an On-sale and Sunday intoxicating liquor license to Toivo's LLC dba Toivo's and consider approval of license contingent upon receipt of proof of insurance and all required fees. If approved, pro-rate license fee through December 31, 2011.

2nd Public Hearing

14. **11-1433** Conduct Public Hearing on CP 2014-1, 1st Avenue NE Reconstruction Project.

Attachments: [4-11-11 CP 2014-1 Attachment Presentation.pdf](#)

Reconvene regular meeting.

15. **11-1434** A resolution ordering in CP 2014-1, 1st Avenue NE Reconstruction Project and the preparation of plans and specifications.

Attachments: [4-11-11 Resolution CP 2014-1 Order Improvement and Plans and Specs.pdf](#)

16. **11-1435** A Supplemental Letter Agreement (SLA) with SEH for design and construction services on CP 2014-1, 1st Avenue NE Reconstruction Project.

Attachments: [4-11-11 Attachment CP 2014-1 SEH SLA .pdf](#)

3rd Public Hearing

17. **11-1436** A public hearing on CP 2011-4, Horseshoe-Isleview Reconditioning Project.

Attachments: [4-11-11 CP 2011-4 Attachment Presentation.pdf](#)

Reconvene regular meeting.

18. **11-1437** A resolution ordering in CP 2011-4, Horseshoe-Isleview Reconditioning Project, and the preparation of plans and specifications.

Attachments: [4-11-11 Resolution CP 2011-4 Order Improvement and Plans and Specs.pdf](#)

7:30 VERIFIED CLAIMS
p.m.

19. **11-1449** Consider approving the verified claims for the period March 22, 2011 to April 4, 2011 in the total amount of \$276,088.85.

Attachments: [4/11/2011 BILL LIST](#)

7:45 ADJOURNMENT
p.m.

Attest:

Shawn Gillen, City Administrator

NEXT REGULAR MEETING IS SCHEDULED FOR APRIL 25, 2011, AT 5:00 P.M.

NOTE: These times are approximate only and are subject to change. If you are interested in a topic of discussion you should appear at least 10 minutes before its scheduled time.

Hearing Assistance Available: This facility is equipped with a hearing assistance system.



CITY OF GRAND RAPIDS

CITY COUNCIL CHAMBERS
420 NORTH POKEGAMA
AVE.

Legislation Details (With Text)

File #: 11-1447 **Version:** 1 **Name:** Council Minutes
Type: Agenda Item **Status:** Approval of Miinutes
File created: 4/6/2011 **In control:** Administration
On agenda: 4/11/2011 **Final action:**
Title: Approve minutes for Monday, March 28, 2011 at 4:00 p.m. and 5:00 p.m. Worksession and Regular meetings.
Sponsors:
Indexes:
Code sections:
Attachments: [March 28, 2011 Worksession](#)
[March 28, 2011 Regular Meeting](#)

Date	Ver.	Action By	Action	Result
------	------	-----------	--------	--------

Title

Approve minutes for Monday, March 28, 2011 at 4:00 p.m. and 5:00 p.m. Worksession and Regular meetings.



CITY OF GRAND RAPIDS

CITY COUNCIL
CHAMBERS
420 NORTH POKEGAMA
AVE.

Minutes - Final - Draft City Council Work Session

Monday, March 28, 2011

4:00 PM

Conference Room 2A

CALL TO ORDER: Pursuant to due notice and call thereof a Special Meeting/Worksession of the Grand Rapids City Council was held on Monday, March 28, 2011 at 4:00 p.m. in Conference Room 2A, 420 North Pokegama Avenue, Grand Rapids, Minnesota.

CALL OF ROLL: On a call of roll, the following members were present:

Present 4 - Mayor Dale Adams, Councilor Gary McInerney, Councilor Dale Christy, and Councilor Ed Zabinski

Absent 1 - Councilor Joe Chandler

Discussion Items

1. Discuss Legistar and Council comments email.

Discussion regarding FYI notification for requests for Council action from departments to Council upon submission of RCA to City Administrator. This would be individual choice of each Council member. IT Director Scott explains process for adding Council members to receive RCA's as they are submitted and how to view information and attachments. This item will be further discussed at a Policy & Ordinance Review meeting.

Council comments email would allow residents to electronically comment on public hearings when they could not be in attendance. This process will be tested at a later date at a Council meeting to see how the process will work.

2. Review 5:00 p.m. meeting agenda.

Addition of Early Retirement Incentive Package. City Administrator Gillen reviews ERIP outline, requirements to qualify, etc. Staff reduction over the last few years has been significant and the City can continue to save funds by offering this program again. More information will be provided at the next Policy & Ordinance Review meeting.

*Correction to insurance premium for League of Minnesota Cities.
Add request for leave of absence for Firefighter William Olson as item 22a.
Discussed memo from Police Chief Jim Denny regarding the Grace House.*

ADJOURN

There being no further business, the meeting adjourned at 4:52 p.m.

Respectfully submitted:

Kimberly Johnson-Gibeau, City Clerk



CITY OF GRAND RAPIDS

CITY COUNCIL
CHAMBERS
420 NORTH POKEGAMA
AVE.

Minutes - Final - Draft City Council

Monday, March 28, 2011

5:00 PM

City Hall Council Chambers

5:00 CALL TO ORDER: Pursuant to due notice and call thereof a Regular Meeting of the
p.m. Grand Rapids City Council was held on Monday, March 28, 2011 at 5:00 p.m. in
Council Chambers, 420 North Pokegama Avenue, Grand Rapids, Minnesota.

5:01 CALL OF ROLL: On a call of roll, the following members were present:
p.m.

Present 4 -

Councilor Gary McInerney, Councilor Dale Christy, Councilor Ed Zabinski,
and Mayor Dale Adams

Absent 1 -

Councilor Joe Chandler

5:02 MEETING PROTOCOL POLICY
p.m.

5:03 PUBLIC FORUM
p.m.

5:10 COUNCIL REPORTS
p.m.

Councilor Zabinski addresses the Council regarding City role in the animal shelter. City Administrator Gillen explains the situation with the humane society and the possibility of that facility closing, though this has not been decided as yet. The City will continue to try to collaborate with surrounding communities to manage the unclaimed animal population. Advise residents to call County Commissioner and the humane society.

Mayor Adams discusses recent Mayors and Managers Meeting which included a GIS presentation to introduce ideas for sharing resources that will help control costs for the City and surrounding communities.

5:12 APPROVAL OF MINUTES
p.m.

Approve minutes for March 14, 2011 at 4:00 p.m. and 5:24 p.m. and Special meeting on March 7, 2011.

A motion was made by Councilor Gary McInerney, seconded by Councilor Dale Christy to approve Council minutes as presented. The motion PASSED by an unanimous vote.

5:13 CONSENT AGENDA
p.m.

A motion was made by Councilor Christy, seconded by Councilor McInerney to approve items 1 through 22 and additional items 22a and 22b on the Consent Agenda. The motion carried by the following vote.

Aye 4 -

Councilor Gary McInerney, Councilor Dale Christy, Councilor Ed Zabinski, and Mayor Dale Adams

1. Approve list of Pokegama GC Seasonal Employees
2. Revision of the City of Grand Rapids Communications Policy.
3. Replace lighting fixtures at the IRA Civic Center.
4. Copier Contract Extension
5. Approve hiring temporary Park and Recreation Employees
6. Request by the Police Department to hold an auction and sell impounded and forfeited vehicles.
7. Request by the Police Department to hold an auction to sell old radios from the old radio system.
8. Schedule a public hearing for April 11, 2011 at 6:00 p.m. to receive public input as it pertains to the issuance of a new on-sale and Sunday liquor license for Toivo's, located at 1212 NW 4th Street, Grand Rapids, MN.
9. Consider approving Itasca County classification of tax-forfeited land.
10. Change Order 3 related to CP 2004-2B, TH Multi-Use Trail
11. A DNR Legacy Trail Grant related to CP 2011-4, Horseshoe-Isleview Reconditioning Project
Adopted resolution 11-36 - approving submittal of MN DNR Trail Legacy Grant Horseshoe-Isleview Trail CP 2011-4
12. A Service Order for GIS Services between the City and GRPUC
13. Receive feasibility report and call for a public hearing on CP 2011-4, Horseshoe-Isleview Reconditioning Project.
Adopted resolution 11-37 - receiving the report and calling for a hearing for

Horseshoe-Isleview Partial Reconditioning CP 2011-4.

14. A resolution receiving the feasibility report and calling for a public hearing on CP 2014-1, 1st Avenue NE Reconstruction.
Adopted resolution 11-38 - receiving the report and calling for a hearing for 1st Avenue NE reconstruction CP 2014-1
15. Completion of Introductory Period for John Nalan, Library Clerk II - Circulation.
16. Completion of Introductory Period for Assistant Chief Steven Schaar.
17. Approve plans and specifications and order the advertisement for bids on CP 2010-3, 19th Avenue NW Rail Crossing Improvements/Closures.
Adopted resolution 11-39 - to approve plans and specifications and order advertisement for bids for 19th Avenue NW rail crossing improvements/closures CP 2010-3
18. Approve the General Liability insurance coverage through the League of Minnesota Cities Insurance Trust for the 2011 plan year and authorize payment of the insurance premium including the agent fee.
19. Extended Medical Leave for William Block.
20. Approve Consumption and Display permit for Itasca County Curling Club.
21. Approve new lease for Central School with Ken Wagner, Barry Nelson and Jeff Argir dba Whispering Woods Gallery.
22. Change to Personnel Policy Manual Section 3.19 Job related media inquiries.
- 22a. Leave of absence request for William Olson, Firefighter.
- 22b. In conjunction with the American Society of News Editors "National Sunshine Week", the Grand Rapids City Council hereby endorse the concept of openness in government. The City Council of Grand Rapids has abided by the Minnesota Open Meeting Law since its inception, and we are proud of our track record in being open with all of our meetings and public information.

5:18 SETTING OF REGULAR AGENDA
p.m.

A motion was made by Councilor Ed Zabinski, seconded by Councilor Dale Christy, to approve the regular agenda as presented. The motion PASSED by an unanimous vote.

5:19 ACKNOWLEDGE BOARDS & COMMISSIONS
p.m.

23. Acknowledge minutes for Boards & Commissions.

Acknowledged minutes from the following:

February 8, 2011 Airport Commission

February 8, 2011 Police Civil Service

February 9, 2011 Library Board

February 15, 2011 Golf Board

February 17, 2011 Central School

February 24, 2011 Police Civil Service Special Meeting

5:20 DEPARTMENT HEAD REPORT
p.m.

24. Public Works Department Head Report

Received and Filed

5:30 CIVIC CENTER, PARKS & RECREATION
p.m.

25. Fishing Pier

A motion was made by Councilor Christy, seconded by Councilor McInerney to approve agreement with the State of Minnesota to construct a public fishing pier at Sylvan Park on the Mississippi River. The motion carried by the following vote.

Aye 4 -

Councilor Gary McInerney, Councilor Dale Christy, Councilor Ed Zabinski, and Mayor Dale Adams

5:35 ADMINISTRATION DEPARTMENT
p.m.

26. Appointment of Mr. Marty Brink to the position of Public Works Maintenance I and creation of one-year eligibility list.

A motion was made by Councilor McInerney, seconded by Councilor Christy to appoint Marty Brink to the position of Public Works Maintenance I and create a one year eligibility list. The motion carried by the following vote.

Aye 4 -

Councilor Gary McInerney, Councilor Dale Christy, Councilor Ed Zabinski, and Mayor Dale Adams

27. Review the Request for Proposal (RFP) seeking consultant services in the preparation of an updated Compensation Study, and authorize staff to issue the RFP for responses.

A motion was made by Councilor Ed Zabinski, seconded by Councilor Dale Christy to authorize staff to issue request for proposals for consultant services

in the preparation of an updated Compensation Study. The motion PASSED by an unanimous vote.

5:45 VERIFIED CLAIMS
p.m.

28. Consider approving the verified claims for the period March 8, 2011 to March 21, 2011 in the total amount of \$586,328.73.

A motion was made by Councilor Zabinski, seconded by Councilor McInerney to approve the verified claims as presented. The motion carried by the following vote.

Aye 4 -

Councilor Gary McInerney, Councilor Dale Christy, Councilor Ed Zabinski, and Mayor Dale Adams

7:50 PRESENTATIONS
p.m.

35. Annual Storm Water Utility Presentation

Received and Filed

Recess regular meeting for 1st public hearing scheduled for 6:00 p.m.

Recess regular meeting at 5:57 p.m. for public hearing at 6:00 p.m.

6:00 PUBLIC HEARINGS
p.m.

29. Conduct a public hearing to receive public input as it pertains to a temporary liquor license for the Boundary Waters Blues Festival and request for special consideration regarding excessive noise after 10:00 p.m. within the city limits, event to be held June 23-26, 2011 at the Itasca County Fairgrounds.

Background information is presented to the Council with specific requests for event hours.

A motion was made by Councilor McInerney, seconded by Councilor Christy to open the public hearing. The motion passed unanimously.

No one wished to speak, therefore the following motion was made.

A motion was made by Councilor McInerney, seconded by Councilor Zabinski to close the public hearing. The motion passed unanimously.

6:15 Reconvene regular meeting.
p.m.

30. Consider approving a temporary liquor license for the Boundary Waters Blues Festival for June 23, 2011 through June 26, 2011 located at the Itasca County

Fairgrounds and grant special consideration regarding excessive noise after 10:00 p.m.

A motion was made by Councilor Christy, seconded by Councilor Zabinski to approve the temporary on-sale liquor license for the Boundary Waters Blues Festival pending receipt of insurance and fees and to grant special consideration as it pertains to excessive noise after 10:00 p.m. The motion carried by the following vote.

Aye 4 -

Councilor Gary McInerney, Councilor Dale Christy, Councilor Ed Zabinski, and Mayor Dale Adams

**6:30 Recess regular meeting for 2nd public hearing.
p.m.**

31.

Conduct a public hearing to consider the rezoning of 1 acre of land from R-1 (One-Family Residential) to LB (Limited Business) located within east half of Block 26, Central Division of Grand Rapids.

Community Development Director Rob Mattei presents background information regarding request to rezone, location and current zoning.

A motion made by Councilor Zabinski, seconded by Councilor McInerney to open the public hearing. The motion passed unanimously.

Pastor Lynn Ronsberg, 169 Hwy , Grand Rapids - provides information regarding Grace House residence within the Zion Lutheran Church. Pastor Ronsberg states it has been an honor and privilege to share a home with Grace House.

Jill Shubert, 2105 Elm Street, Grand Rapids. Previous director of Grace House. Discusses volume of families/individuals served. Most had never been homeless before. At least 50% have changed their lives by getting assistance in finding employment and permanent housing.

Rick Hocking, 418 SW 2nd Ave, Grand Rapids. Object to the rezoning of the subject property. Located 350 feet from our home and do not wish to have this "caliber" of individuals in our neighborhood. Most are alcoholics and drug addicts.

Dan Hess, 20190 Happy Hollow Road, Grand Rapids. Crisis Management worker in Itasca County. In favor of the rezone. There have been no incidents involving placement of individuals in the housing facilities nor at Grace House.

Randall Carlson, 36104 Wabana Road, Veteran's Services. The Grace House has assisted many veterans. This provides a much needed humanitarian service.

Vicki Andrews, Grace House Board Member. Speaks in support of Grace House, reviewing the volunteers and the schedule. The people using Grace House are ordinary people that have fallen on hard times.

Dawn Stoll, 112 SW 6th Street, lives across the street from the proposed rezone property. Fear for safety. What about the people who are turned away and remain in the neighborhood. What sort of individuals will start coming into the neighborhood. Rarely see police presence in the neighborhood. Against the rezoning of this piece of property.

Annette Budrow, 4th Street, Grand Rapids. Against the rezone. Thinks Grace House is a great project but does not believe this project should be in a residential area. Suggests placing Grace House near the IRC building where these people can get to the soup kitchen and find work. All for Grace House but not in her backyard.

Jim Martinetto, 1507 SW 3rd Avenue, Board of Director of Hope House. No correlation in crime rate when you introduce one of these facilities into a neighborhood. This is not a flop house for drunks, sexual predators or other criminals. Homelessness is not a crime. This is a needed service and does not believe this will inflate the crime in the Southwest area. Recommend approval because this is a needed facility.

Kathy Wettersten, 4th Street, Grand Rapids, does not believe those present think that Grace House is a bad place. Hard time believing that this is the only place that the Grace House can relocate. Not worried about the people who escape the system. Shouldn't put a business in the neighborhood. Increased traffic. Ms. Wettersten reads letter that was presented to the Council as attachment to public hearing.

Bob Wagner, 715 SW 2nd Avenue, volunteer for Grace House. There is no reason to fear the people utilizing Grace House.

Lisa Hain, 712 NW 6th Avenue, Grand Rapids. Speaking in support for this opportunity for Grace House. Never had a concern about a Grace House guest.

Doug Veit, rural Grand Rapids resident. Would like to help others feel better about the people staying at the Grace House. We are all just one accident or one decision in life from losing everything. It could be any one of us. Supporting rezone.

Pat Medure, Grand Rapids, states that fear creates anxiety and we need to look at the past examples of Grace House. Calls for service to PD can happen in any neighborhood and are not specific to homes like Grace House.

Norene Haatula, 1104 SE 4th Street, discusses the fear factor. 1 in 4 people have mental illness and that may speak to the fear of people at Grace House. Most sexual assaults, molestation are perpetrated by people known to the victims. How many of the people at Grace House are children? Statistics don't lie. You can research this issue. Speaking in support of rezone for Grace House.

Marva Jean Hutchins, 3105 SW 3rd Avenue, thanks Zion for their hospitality. This is an opportunity to build relationships with the community and collaboration of neighborhoods. This can be a win win to build stronger partnership.

Nancy Alfuth, 4th St & 5th Avenue SW, did not sign petition. In favor of rezone for Grace House with no fear. Strongly believe they need a permanent home.

Teresa, guest of Grace House. Is grateful for assistance. Is now employed. Looking at a permanent home. I am not a criminal, just a person who had hard luck.

Jake Mutchler, Southwest neighborhood, has children who ride bikes in neighborhood. These people are strangers. Not good for the neighborhood, not good for property and should not be in the residential neighborhood.

Mary Ruby, Sunny Beach Road, Grand Rapids. Volunteers at Grace House and has never felt unsafe. Happy that the Grace House has the opportunity to purchase the property and never heard anything bad about Grace House.

Jan Streeter, 7th Avenue SE, would like to represent other neighborhoods. Thinks the Grace House is a great place. Asks the Council to listen to the neighbors. If this was in my neighborhood, I would want you to listen to me.

Heidi, staying at Grace House. Appreciates Grace House. They have helped with a place to sleep and shower. Working on finding employment, housing and are grateful for the assistance.

Fred Roldan, member of Jehovah Witness Church currently located on this property. aware of dangers that can come to the community. Many times have called the police due to vandalism. Vandalism stopped when there were more people around the property. There were times when they had trouble with the kids in the neighborhood. In favor of Grace House moving in.

Linda Hollenbeck, SW 2nd Avenue, would not have purchased her house in this neighborhood had she known there would be a homeless shelter there. Will there be people sleeping out on the property? Will they be loitering and hanging around looking for someplace else to stay if they can't get in to Grace House? Against the rezone.

Kathy Solem, President of Zion Lutheran Church Council, states that this organization would not have lasted in the church for this long if there had been issues. Grace House has been wonderful tenants and there is no reason to fear.

Mary Kay Jacobson, Zion Lutheran Church Council. Grace House deserves a place where they don't have to leave on Sundays. Aren't forced out over the holidays with no place else to go. Highly recommend that the Council approve the zoning change requested.

Diane Larson, 2521 Timberline Drive, HRA. On behalf of HRA, there is not enough affordable housing in our community. Worked with Grace House staff and they are well trained. As a member of Zion, the same concerns expressed when Grace House moved into Zion. Live one block west of the Church and there has been absolutely no problems that can be attributed Grace House.

Kathy Vassen, Grand Rapids, is volunteer coordinator at Grace House. The staff are trained well and are held accountable. Policy and procedure is strictly followed. Background checks are run and a very long intake interview.

Audrey Moen, LaPrairie, would have no concern for Grace House coming into her neighborhood.

Annette Budrow, stresses that she is a spiritual person and a compassionate person. This is our neighborhood, our block, and the people in the neighborhood do not want this.

Jim Martinetto, points out that there is limited business right across the street from the subject project. If they had purchased property across the street, this would not be an issue for public hearing.

Dawn Stoll, lives across the street from subject property. What about people that are turned away? Where do they go? Do they stay in the neighborhood, do they leave and come back drunk or using drugs. Grace House does not run drug tests on individuals asking for shelter.

No one else wished to speak, therefore the following motion was made.

A motion was made by Councilor Zabinski, seconded by Councilor McInerney to close the public hearing. The motion passed unanimously.

Mr. Mattei advises the Council that he prepared draft ordinance based on Planning Commission recommendations. Findings of fact of Planning Commission are included.

**7:00 Reconvene regular meeting.
p.m.**

32. Consider the recommendation of the Planning Commission regarding adoption of an ordinance amending the Official Zoning Map by rezoning Lots 1-12, Blk. 26, Central Division of Grand Rapids from the established R-1 (One-family Residential) zoning to LB (Limited Business) zoning.

A motion was made by Councilor Zabinski, seconded by Councilor Christy to adopt Ordinance 11-03-02 - amending the Official Zoning Map by rezoning Lots 1-12, Blk. 26, Central Division of Grand Rapids from the established R-1 (One-family Residential) zoning to LB (Limited Business) zoning. The motion carried by the following vote.

Aye 4 -

Councilor Gary McInerney, Councilor Dale Christy, Councilor Ed Zabinski, and Mayor Dale Adams

**7:10 Recess regular meeting for 3rd public hearing.
p.m.**

33. Conduct a Public Hearing to consider the adoption of an Ordinance amending Section 30-512 Table-1 (*Permitted Uses*) of the Land Development Regulations that would add Recycling Center uses, as a permitted use, within the PU/SPU (Public Use/Shoreland Public Use) zoning district.

Community Development Director Mattei provides background information regarding Deer River Hired Hands request to operate a recycling center at the old waste water treatment facility on River Road.

A motion was made by Councilor McInerney, seconded by Councilor Zabinski to open the public hearing. The motion passed unanimously.

Lonnie Aultman, 5th Street, concerned about the smell. Has been very happy that the sewage plant is moving out, but does not believe that the problem will be gone as recycling is a process that creates a strong odor.

Mono Sjostrand, 522 SE 14th Avenue, put up with the smell for 31 years. The noise from trucks, and what not have been a problem also. There are other facilities at the fairgrounds that could be rezoned. Would prefer that a lease be shortterm and re-evaluate regularly. If people drop recyclables at the gate, this material will wind up in the neighborhood yards, the river and the streets. Find another place.

Steve Oleseiser, 1403 SE 5th Street, lived in home for 51 years, with major remodeling in the last few years. What will come in next if this does not work? There are better areas in the community for recycling.

Judy Schroader, 2022 River Road, Support recycling center in Grand Rapids. This has been a great benefit for the employees of Deer River Hired Hands. Provide a very good service.

Shawn Linder, 502 14th Avenue SE, these facilities are noisy and there is an odor. Opposed to having the recycling center in this location.

Dean Singsank, customer and father of employee at Deer River Hired Hands. Created jobs for this community. Supports this text amendent.

Peter McDermott, MDI, speaking in support of Deer River Hired Hands and the proposed recycling center in Grand Rapids.

Davin Tinquist, resident of Cohasset, County Commissioner. Supporting the facts for Deer River Hired Hands. Kept very clean and there is not a strong odor leaking into the community. Never received complaints regarding the recycling center.

Mary Kay Jacobson, speaks in support of Deer River Hired Hands.

Shawn Burgraff, 1817 River Road, strong smell from sewage plant. Speaking against the placement of recycling center. Recommends that industrial size recycling bins can be utilized around the community or set in the industrial park where residents can drop off recycling and then have it hauled to Deer River.

Rodney Wood, 715 NW 9th Street, speaks in support of Deer River Hired Hands locating in this area.

Bob Gardner, president of Deer River Hired Hands. This facility is currently in a residential area in Deer River, and there have been no problems, no smell, no noise. Concerns expressed have never been an issue. Mr. Gardner urges Council to support this request.

Duane ?, Sunny Beach Road, uses Deer River Hired Hands recycling and supports the new site.

Shawn Linder, points out that Waste Management offers recycling. Questions the fee for rental and if the property was open for rent to everyone or just Deer River Hired Hands.

Steve Oleheiser, not against creating jobs in Grand Rapids, this effects other neighborhoods, and concerned about \$1 a year lease as a tax payer.

Mono Sjostrand, states that she too would like to rent the building for low cost. Concerns about traffic and noise created by excessive traffic. Believes that Deer River Hired Hands is a great business, but does not want this facility in their backyard.

No one else wished to speak, therefore the following motion was made.

A motion by Councilor McInenery, seconded by Councilor Christy to close the public hearing. The motion passed unanimously.

**7:40 Reconvene regular meeting.
p.m.**

34.

Consider the recommendation of the Planning Commission to adopt an Ordinance amending Section 30-512 Table-1 (*Permitted Uses*) of the Land Development Regulations that would add Recycling Center uses, as a permitted use, within the PU/SPU (Public Use/Shoreland Public Use) zoning district, and authorize its publication in summary form.

Staff answers questions regarding lease amount, time frame for removal of tanks, if and when, lessee responsible for insurance and maintenance of facility.

A motion by Councilor Christy, seconded by Councilor Zabinski to extend the 60 day rule for another 60 days and direct staff to make notification in writing. The motion passed unanimously.

A motion was made by Councilor Ed Zabinski, seconded by Councilor Gary McInerney, to table this item. The motion PASSED by an unanimous vote.

8:00 ADJOURNMENT
p.m.

There being no further business, the meeting adjourned at 9:38 p.m.

Respectfully submitted:

Kimberly Johnson-Gibeau, City Clerk



Legislation Details (With Text)

File #: 11-1427 **Version:** 1 **Name:** Request by the Police Department to hold an auction and sell impounded vehicles.

Type: Agenda Item **Status:** Consent Agenda

File created: 3/31/2011 **In control:** Police

On agenda: 4/11/2011 **Final action:**

Title: Request by the Police Department to hold an auction and sell impounded vehicles.

Sponsors:

Indexes:

Code sections:

Attachments:

Date	Ver.	Action By	Action	Result
------	------	-----------	--------	--------

Title

Request by the Police Department to hold an auction and sell impounded vehicles.

Background Information:

The Police Department has held auctions for several years to dispose of impounded vehicles. The auction will be held at the police impound facility and online this year. DO-BID, Oberfoell Auctioneers, who we have used in the past, will be auctioning the vehicles for us this year so we can get top dollar for them. Per state statute all registered owners and lien holders have been notified of the impoundment of the vehicles and to this date the vehicles have not been claimed. They are considered abandoned at this point, and can be legally sold by the city.

Money earned from the sale of these vehicles will be distributed according to state statute and city policy. The auction will be held over a two week period beginning April 28, 2011.

Vehicle descriptions are as follows:

ICR # MAKE/MODEL VIN#

10003323 2004 Chevy Trail Blazer 1GNET16P846100462 (IMPOUND)

10011694 1979 Dodge Pickup D14AE9X186176 (IMPOUND)

11001162 1986 ford Ranger Pickup 1FTBR10TXGUD03885 (IMPOUND)

Requested City Council Action

Consider a request by the Police Department to sell impounded vehicles at auction to be held for a two week period beginning on April 28, 2011.



Legislation Details (With Text)

File #: 11-1438 **Version:** 1 **Name:** CP 2009-11B Order Project
Type: Agenda Item **Status:** Consent Agenda
File created: 4/4/2011 **In control:** Engineering
On agenda: 4/11/2011 **Final action:**
Title: A resolution approving the plans and specifications and the advertisement of bids for CP 2009-11B, Riverfront Energy Center.
Sponsors:
Indexes:
Code sections:
Attachments: [4-11-11 RESOL CP 2009-11B Ordering Advertisement.pdf](#)

Date	Ver.	Action By	Action	Result
------	------	-----------	--------	--------

Title

A resolution approving the plans and specifications and the advertisement of bids for CP 2009-11B, Riverfront Energy Center.

Body

Background Information:

The plans and specifications are complete for CP 2009-11B, Riverfront Energy Center. This is the project that will take heat from the UPM/Blandin waste stream and utilize it to supplement the heating of the public library. A resolution approving the plans and specifications and ordering the advertisement for bids is attached.

Staff Recommendation:

City staff is recommending the attached resolution approving the plans and specifications and the advertisement of bids for CP 2009-11B, Riverfront Energy Center.

Requested City Council Action

Consider a resolution approving the plans and specifications and the advertisement of bids for CP 2009-11B, Riverfront Energy Center.

Council member _____ introduced the following resolution and moved for its adoption:

RESOLUTION NO. 11-__

**A RESOLUTION TO APPROVE PLANS AND SPECIFICATIONS AND
ORDER ADVERTISEMENT FOR BIDS FOR
RIVERFRONT ENERGY CENTER
CITY PROJECT 2009-11B**

WHEREAS, the City Council, on the 10th day of January, 2011, directed the preparations of plans and specifications for City Project 2009-4, Riverfront Energy Center, and

NOW, THEREFORE, BE IT RESOLVED BY THE CITY COUNCIL OF GRAND RAPIDS,
MINNESOTA:

1. The plans and specifications for this project, copies of which were presented to the City Council and on file in the City Engineer's office, are hereby approved.
2. The City Clerk shall prepare and cause to be inserted in the official paper an advertisement for bids upon the making of such improvement under such approved plans and specifications. The advertisement shall be published for 21 days, shall specify the work to be done, shall state that bids will be received by the Clerk until 1:00 p.m., on Wednesday, May 11, 2011, at which time they will be publicly opened in the Council Chambers of the City Hall by the City Clerk and Engineer, will then be tabulated, and will be considered by the Council at the regular meeting of the Council at 5:00 p.m., Monday, May 23, 2011, in the Council Chambers. Any bidder whose responsibility is questioned during consideration of the bids will be given an opportunity to address the Council on the issue of responsibility. No bids will be considered unless sealed and filed with the Clerk and accompanied by a cash deposit, cashier's check, bid bond, or certified check payable to the Clerk for 5 percent (5%) of the amount of such bid.

Adopted by the Council this 11th day of April, 2011.

Dale Adams, Mayor

ATTEST:

Kim Johnson-Gibeau, City Clerk

Council member _____ seconded the foregoing resolution and the following voted in favor thereof: _____; and the following voted against same: _____; whereby the resolution was declared duly passed and adopted.

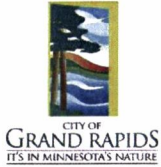

Legislation Details (With Text)

File #: 11-1441 **Version:** 1 **Name:** Employee Ratification
Type: Agenda Item **Status:** Consent Agenda
File created: 4/6/2011 **In control:** Civic Center, Parks & Recreation
On agenda: 4/11/2011 **Final action:**
Title: Approve the hiring of the employees listed with the Grand Rapids Park and Recreation Department.
Sponsors:
Indexes:
Code sections:
Attachments:

Date	Ver.	Action By	Action	Result
------	------	-----------	--------	--------

Title

Approve the hiring of the employees listed with the Grand Rapids Park and Recreation Department.

Body

Background Information:

These positions are part of the 2011 Programming Budget

Staff Recommendation:

Consider approving the hiring of the employees listed with the Grand Rapids Park and Recreation Department.

Requested City Council Action

Consider approving the hiring of the employees listed with the Grand Rapids Park and Recreation Department.



CITY OF GRAND RAPIDS

CITY COUNCIL CHAMBERS
420 NORTH POKEGAMA
AVE.

Legislation Details (With Text)

File #: 11-1442 **Version:** 1 **Name:** Grand Rapids Jaycee's Donation
Type: Agenda Item **Status:** Consent Agenda
File created: 4/6/2011 **In control:** Civic Center, Parks & Recreation
On agenda: 4/11/2011 **Final action:**
Title: Donation from the Grand Rapids Jaycees
Sponsors:
Indexes:
Code sections:
Attachments: [Jaycees Donation Resolution](#)

Date	Ver.	Action By	Action	Result
------	------	-----------	--------	--------

Title

Donation from the Grand Rapids Jaycees

Body

Background Information:

The Grand Rapids Jaycees have given a donation of \$500.00 to the Grand Rapids Park and Recreation Department to help purchase youth t-shirts for the Spring Into Fitness event on April 15, 2011.

Staff Recommendation:

Consider adopting a resolution accepting a donation of \$500.00 from the Grand Rapids Jaycees to the Park and Recreation Department for the Spring Into Fitness event on April 15, 2011.

Requested City Council Action

Consider adopting a resolution accepting a donation of \$500.00 from the Grand Rapids Jaycees to the Park and Recreation Department for the Spring Into Fitness event on April 15, 2011.

Council member introduced the following resolution and moved for its adoption:

RESOLUTION NO. 11-

A RESOLUTION ACCEPTING A \$500 DONATION FROM THE GRAND RAPIDS JAYCEES TO THE GRAND RAPIDS RECREATION DEPARTMENT TO HELP PAY FOR THE YOUTH T-SHIRTS FOR THE SPRING INTO FITNESS EVENT ON APRIL 15, 2011

WHEREAS, Minnesota State Statutes 465.03, states that cities may accept gifts of real or personal property, including money, and use them in accordance with the terms the donor prescribes; and

WHEREAS, every such acceptance shall be by resolution of the governing body adopted by two-thirds majority of its members,

NOW THEREFORE, BE IT RESOLVED, the City Council of the City of Grand Rapids, Itasca County, Minnesota, accepts the listed donation and terms of the donor as follows:

- The Grand Rapids Jaycees have donated \$500 to the Grand Rapids Recreation Department to be used to help purchase youth t-shirts for the Spring Into Fitness Event on April 15, 2011.

Adopted this 11th day of April, 2011

Dale C. Adams, Mayor

Attest:

Kimberly Johnson-Gibeau, City Clerk

Councilmember seconded the foregoing resolution and the following voted in favor thereof; and the following voted against same: None, whereby the resolution was declared duly passed and adopted.

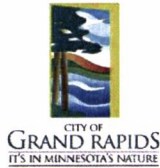

Legislation Details (With Text)

File #: 11-1443 **Version:** 1 **Name:** Consider the donation of old computers to PCs for People.
Type: Agenda Item **Status:** Consent Agenda
File created: 4/6/2011 **In control:** Information Technology
On agenda: 4/11/2011 **Final action:**
Title: Consider the donation of old computers to PCs for People.
Sponsors:
Indexes:
Code sections:
Attachments: [PCs for People Articles of Incorporation.pdf](#)
[Computer Donation List 2011.pdf](#)

Date	Ver.	Action By	Action	Result
------	------	-----------	--------	--------

Title

Consider the donation of old computers to PCs for People.

Body

Background Information:

As we replace computers and other equipment on our network, we have older equipment for disposal. In the past, the IT Department would dispose of the equipment at a cost to each department or hold an auction to get some of the functional equipment back out into the community. The auction process would rarely generate enough revenue to cover the expense of advertising and staff time. This year, I would like to donate our used equipment to PCs for People. PCs for People is a non-profit group that refurbishes old computers and sells them at a low cost to people who otherwise could not afford a computer. They have made an agreement with Kootasca to put some of these donated computers back into our community.

Requested City Council Action

Consider the donation of 37 old computers to PCs for People.

INTERNAL REVENUE SERVICE
P. O. BOX 2508
CINCINNATI, OH 45201

DEPARTMENT OF THE TREASURY

JUN 22 2008

Date:

PCS FOR PEOPLE
PO BOX 3526 410 S 5TH ST
MANKATO, MN 56002-3526

Employer Identification Number:
26-2066045
DLN:
17053130006008
Contact Person:
RONALD D BELL ID# 31185
Contact Telephone Number:
(877) 829-5500
Accounting Period Ending:
April 30
Public Charity Status:
509(a)(2)
Form 990 Required:
Yes
Effective Date of Exemption:
April 16, 2008
Contribution Deductibility:
Yes
Advance Ruling Ending Date:
April 30, 2012
Addendum Applies:
No

Dear Applicant:

We are pleased to inform you that upon review of your application for tax exempt status we have determined that you are exempt from Federal income tax under section 501(c)(3) of the Internal Revenue Code. Contributions to you are deductible under section 170 of the Code. You are also qualified to receive tax deductible bequests, devises, transfers or gifts under section 2055, 2106 or 2522 of the Code. Because this letter could help resolve any questions regarding your exempt status, you should keep it in your permanent records.

Organizations exempt under section 501(c)(3) of the Code are further classified as either public charities or private foundations. During your advance ruling period, you will be treated as a public charity. Your advance ruling period begins with the effective date of your exemption and ends with advance ruling ending date shown in the heading of the letter.

Shortly before the end of your advance ruling period, we will send you Form 8734, Support Schedule for Advance Ruling Period. You will have 90 days after the end of your advance ruling period to return the completed form. We will then notify you, in writing, about your public charity status.

Please see enclosed Publication 4221-PC, Compliance Guide for 501(c)(3) Public Charities, for some helpful information about your responsibilities as an exempt organization.

Letter 1045 (DO/CG)



Computer Donation List

1. 638933\ EQ012604
2. CPT0207-34
3. 0025102059
4. 723557-8 EQ011005
5. 723557-16 EQ011005
6. 723557-20 EQ011005
7. CPT1205-51
8. 723557-11 EQ011005
9. 0025102058
10. ESE7J
11. 723557-10 EQ011005
12. 603482-2 EQ060203
13. 723557-18 EQ011005
14. 632616-2 EQ121103
15. 479765 MN04/01
16. 0020607651
17. 723557-7 EQ011005
18. 723557-5 EQ011005
19. 723557-3 EQ011005
20. 723557-9 EQ011005
21. 723557-22 EQ011005
22. 632616-4 EQ121103
23. 723557-13 EQ011005
24. 723557-15 EQ011005
25. 618165-1 EQ091003
26. 594979 EQ040103
27. 723557-21 EQ011005
28. 723557-17 EQ011005
29. 538801 EQ041502
30. 723557-19 EQ011005
31. 723557-12 EQ011005
32. 723557-14 EQ011005
33. 638933-1 EQ012604
34. 651419-1 EQ051304
35. 632616-3 EQ121103
36. 651419-2 EQ051304
37. 651419-4 EQ051304

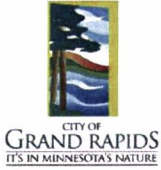

Legislation Details (With Text)

File #: 11-1450 **Version:** 1 **Name:** Capital Planning Software Plan-It! License Renewal
Type: Agenda Item **Status:** Consent Agenda
File created: 4/6/2011 **In control:** Finance
On agenda: 4/11/2011 **Final action:**
Title: Consider approving the annual renewal of the license for the Capital Planning Software PlanIt.

Sponsors:

Indexes:

Code sections:

Attachments:

Date	Ver.	Action By	Action	Result
------	------	-----------	--------	--------

Title

Consider approving the annual renewal of the license for the Capital Planning Software *PlanIt*.

Body

Background Information:

The City is currently using the Capital Planning Software *PlanIt*. The license has to be renewed on an annual basis. The renewal rate for 2011 is \$1,442.81. This is the same renewal rate as 2010. This is in the Finance Department's budget.

Requested City Council Action

Consider approving the annual renewal of the license for the Capital Planning Software *PlanIt*.

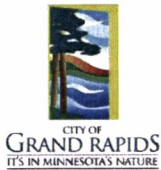

CITY OF GRAND RAPIDS

CITY COUNCIL CHAMBERS
420 NORTH POKEGAMA
AVE.

Legislation Details (With Text)

File #: 11-1445 **Version:** 1 **Name:** Northland Counseling Revenue Notes
Type: Agenda Item **Status:** Consent Agenda
File created: 4/6/2011 **In control:** Finance
On agenda: 4/11/2011 **Final action:**
Title: Consider adopting a resolution approving amendments to the Economic Development Revenue Notes for Northland Counseling Center Project, Series 2002A and 2002B and related documents.
Sponsors:
Indexes:
Code sections:
Attachments: [Economic Development Rev Notes-Northland Counseling](#)

Date	Ver.	Action By	Action	Result
------	------	-----------	--------	--------

Title

Consider adopting a resolution approving amendments to the Economic Development Revenue Notes for Northland Counseling Center Project, Series 2002A and 2002B and related documents.

Body

Background Information:

In 2002, the City of Grand Rapids issued Economic Development Revenue Notes for Northland Counseling Center. Economic Development Revenue Notes are not an obligation of the City, but a vehicle to issue a note for a non-profit that will be purchased by a banking institution. In this case, the Notes were purchased by American Bank of the North. American Bank and Northland Counseling have agreed to a lower interest rate on the Notes from 5.0% per year to 3.8% per year. This change will result in significant debt service savings.

Federal tax law requires that certain documents, including a new 8038 IRS reporting form be signed by City officials to effectuate the interest change. The attached resolution will authorize the modification of the Notes and authorize the Mayor and City Administrator to execute the necessary documents.

Attached please find a letter from the City's Bond Counsel explaining the request, the resolution, and the Acknowledgement and Consent Form.

Requested City Council Action

Consider adopting a resolution approving amendments to the Economic Development Revenue Notes for Northland Counseling Center Project, Series 2002A and 2002B and related documents.

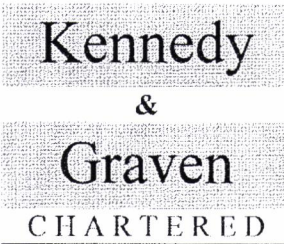

470 US Bank Plaza
200 South Sixth Street
Minneapolis MN 55402

(612) 337-9300 telephone
(612) 337-9310 fax
<http://www.kennedy-graven.com>

MEMORANDUM

TO: Shirley Miller, Financial Director

FROM: Ben Johnson and Rhonda Skoby

DATE: April 5, 2011

RE: City of Grand Rapids, Minnesota, Economic Development Revenue Notes (Northland Counseling Center Project), Series 2002A and Series 2002B

In 2002, the City of Grand Rapids (the "City") issued the above-mentioned notes (the "Notes") in favor of American Bank of the North, a state bank organized under the laws of the State of Minnesota (the "Lender"), the proceeds of which were loaned to Northland Counseling Center, Inc., a Minnesota nonprofit organization (the "Borrower"). The Borrower used the proceeds of the Notes to finance: (i) certain improvements to its headquarters office located at 215 Southeast Second Avenue in the City; (ii) the prepayment of taxable indebtedness with respect to certain existing facilities of the Borrower within the City; and (iii) the acquisition of two adult foster care facilities located in the City for persons with significant and persistent mental illness.

The Lender and the Borrower have agreed to lower the interest rate on the Notes from 5.0% per year to 3.8% per year, until the Adjustment Date (as defined in the Loan Agreement) on October 30, 2012. This change will result in significant debt service savings for the Borrower.

The attached resolution will authorize the modification of the Notes and authorize the Mayor and City Administrator to execute the necessary documents. Federal tax law requires that certain documents, including a new 8038 IRS reporting form, be signed by City officials to effectuate the interest change.

Please feel free to contact either Ben Johnson or Rhonda Skoby with any questions. Ben may be reached at 612-337-9259 or bjohnson@kennedy-graven.com, and Rhonda may be reached at 612-337-9283 or rskoby@kennedy-graven.com.

CITY OF GRAND RAPIDS, MINNESOTA

Resolution No. 2011- _____

**A RESOLUTION OF THE CITY OF GRAND RAPIDS, MINNESOTA
APPROVING AMENDMENTS TO ECONOMIC DEVELOPMENT REVENUE
NOTES (NORTHLAND COUNSELING CENTER PROJECT), SERIES 2002A
AND SERIES 2002B AND RELATED DOCUMENTS**

WHEREAS, the City of Grand Rapids, Minnesota (the "City"), issued its (i) Economic Development Revenue Note (Northland Counseling Center Project), Series 2002A, in the original aggregate principal amount of \$510,200, and (ii) Economic Development Revenue Note (Northland Counseling Center Project), Series 2002B, in the original aggregate principal amount of \$797,100 (the "Notes") and loaned the proceeds derived from the sale of the Notes to Northland Counseling Center, Inc., a Minnesota nonprofit corporation (the "Borrower"), pursuant to the terms of a Loan Agreement, dated as of October 1, 2002 (the "Loan Agreement"), between the City and the Borrower, to finance: (i) certain improvements to the Borrower's headquarters office located at 215 Southeast Second Avenue in the City; (ii) the prepayment of taxable indebtedness with respect to certain existing facilities of the Borrower within the City; and (iii) the acquisition of two adult foster care facilities located in the City for persons with significant and persistent mental illness; and

WHEREAS, the principal of and interest on the Notes are payable solely from the amounts derived from amounts to be paid by the Borrower under the Loan Agreement;

WHEREAS, the Notes are not general or moral obligations of the City and do not give rise to a pecuniary liability of the City (except from the revenues to be derived from the Loan Agreement which are pledged to the payment of the Notes), and in any event shall not give rise to a charge against the credit or general taxing powers of the City; and

WHEREAS, the Borrower and American Bank of the North, a state bank organized under the laws of the State of Minnesota (the "Lender"), have agreed to reduce the interest rate on the Notes to 3.8% for the period prior to the next Adjustment Date (October 30, 2012), as evidenced by the Note and Loan Modification Agreement (the "Modification Agreement"), between the Borrower and the Lender.

NOW, THEREFORE, BE IT RESOLVED BY THE CITY COUNCIL OF THE CITY OF GRAND RAPIDS, MINNESOTA THAT:

Section 1. The City hereby acknowledges and consents to the Modification Agreement, and authorizes and directs the Mayor of the City (the "Mayor") and the City Administrator of the City (the "City Administrator") to execute an Acknowledgement and Consent to the Modification Agreement (the "Acknowledgement"), and to deliver the Modification Agreement to the Borrower and Lender.

The Modification Agreement shall be substantially in the form on file with the City on the date hereof, and is hereby approved, with such changes as shall be approved by the City Administrator pursuant to this section, and with such necessary and appropriate variations, omissions, and insertions as are not materially inconsistent with such form and as the City Administrator, in his discretion, shall determine; provided that the execution of the Acknowledgement thereof by Mayor and City Administrator shall be conclusive evidence of such determination.

Section 2. Except as otherwise provided in this resolution, all rights, powers, and privileges conferred, and duties and liabilities imposed, upon the City by the provisions of this resolution or other documents referred to above shall be exercised or performed by the City, or by such officers, board, body, or agency as may be required or authorized by law to exercise such powers and to perform such duties. No covenant, stipulation, obligation, representation, or agreement herein contained or contained in the other documents relating to the Notes shall be deemed to be a covenant, stipulation, obligation, representation, or agreement of any officer, agent, or employee of the City in that person's individual capacity, and neither the members of the City Council of the City nor any officer or employee executing the Acknowledgment shall be liable personally on the Note or be subject to any personal liability or accountability by reason of the issuance thereof.

Section 3. Except as herein otherwise expressly provided, nothing in this resolution or in the Modification Agreement, expressed or implied, is intended or shall be construed to confer upon any person, firm, or corporation other than the City and the Lender, as the holder of the Notes, any right, remedy, or claim, legal or equitable, under and by reason of this resolution and the amended Notes or any provision hereof or of the Modification Agreement.

Section 4. In case any one or more of the provisions of this resolution or of the Modification Agreement, the Loan Agreement, or the Notes shall for any reason be held to be illegal or invalid, such illegality or invalidity shall not affect any other provision of this resolution or of the Modification Agreement, the Loan Agreement, or the Notes, but this resolution, the Modification Agreement, the Loan Agreement, and the Notes shall be construed as if such illegal or invalid provision had not been contained therein.

Section 5. The members of the City Council of the City, officers of the City, and attorneys and other agents or employees of the City are hereby authorized to do all acts and things required by them by or in connection with this resolution and the Modification Agreement and the other documents referred to above for the full, punctual, and complete performance of all the terms, covenants, and agreements contained in the Notes, the Loan Agreement, the Modification Agreement, and this resolution.

Section 6. The Mayor and the City Administrator of the City are authorized and directed to execute and deliver any and all certificates, agreements or other documents which are required by the Loan Agreement, the Modification Agreement, the Notes, or any other agreements, certificates or documents which are deemed necessary by Kennedy & Graven, Chartered, as bond counsel to the City.

Section 7. If for any reason the Mayor or the City Administrator of the City is unable to execute and deliver those documents referred to in this resolution, any other member of the City Council of the City may execute and deliver such documents with the same force and effect as if such documents were executed by the Mayor.

Section 8. This resolution shall be in full force and effect from and after its passage.

PASSED AND APPROVED this 11th day of April, 2011.

THE CITY OF GRAND RAPIDS, MINNESOTA

Mayor

ATTEST:

City Clerk

GR220-55 (BWJ)
384250v1

ACKNOWLEDGEMENT AND CONSENT

The City of Grand Rapids, Minnesota (the "City"), hereby acknowledges and consents to the Note and Loan Modification Agreement by and between Northland Counseling Center, Inc. and American Bank of the North with regard to the City's Economic Development Revenue Note (Northland Counseling Center Project), Series 2002A and Economic Development Revenue Note (Northland Counseling Center Project), Series 2002B.

**CITY OF GRAND RAPIDS,
MINNESOTA**

By: _____
Its: Mayor

By: _____
Its: City Administrator



CITY OF GRAND RAPIDS

CITY COUNCIL CHAMBERS
420 NORTH POKEGAMA
AVE.

Legislation Details (With Text)

File #:	11-1446	Version:	1	Name:	Library transfer for 2010 Maintenance of Effort
Type:	Agenda Item	Status:		Status:	Consent Agenda
File created:	4/6/2011	In control:		In control:	Finance
On agenda:	4/11/2011	Final action:		Final action:	
Title:	Consider adopting a resolution authorizing an \$18,309 transfer from the General Fund to the Grand Rapids Public Library Fund for the 2010 Minimum Local Support Requirement.				
Sponsors:					
Indexes:					
Code sections:					
Attachments:	Library operating transfer \$18,309 for 2010 Letter from Arrowhead Library System				

Date	Ver.	Action By	Action	Result
------	------	-----------	--------	--------

Title

Consider adopting a resolution authorizing an \$18,309 transfer from the General Fund to the Grand Rapids Public Library Fund for the 2010 Minimum Local Support Requirement.

Body

Background Information:

The City is required to provide a minimum level of support to the Library on an annual basis. The City budgeted the amount required of \$519,716. However, the City lost \$218,500 in Market Value Homestead Credit, of which the Library would have received approximately, \$23,000. The City does not receive the final tax payment from the County until approximately the third week in January. After all of the taxes were allocated, the contribution made by the City was \$18,309 short of the required amount.

Attached is a letter from the Arrowhead Library System stating that it is still possible to address the 2010 shortfall in 2011. The Arrowhead Library System would need a copy of a resolution by the City of Grand Rapids that transfers the shortfall of \$18,309 to the Library Fund to avoid any negative impact on the Library's continued membership in the Arrowhead Library System. This contribution for 2010 in 2011 does not count towards the 2011 required contribution.

Requested City Council Action

Consider adopting a resolution authorizing an \$18,309 transfer from the General Fund to the Grand Rapids Public Library Fund for the 2010 Minimum Local Support Requirement.

Council member introduced the following resolution and moved for its adoption:

RESOLUTION NO. 11-

AUTHORIZE AN \$18,309 OPERATING TRANSFER FROM THE GENERAL FUND TO
THE GRAND RAPIDS PUBLIC LIBRARY TO MEET THE 2010 MINIMUM LOCAL
SUPPORT REQUIREMENT

WHEREAS, the City is required to provide a minimum level of support to the Library on an annual basis, and

WHEREAS, the City budgeted the required amount for 2010, and

WHEREAS, the City lost \$218,500 in Market Value Homestead Credit of which the Library would have received approximately \$23,000, and

WHEREAS, the contribution made by the City was \$18,309 short of the required contribution, and

WHEREAS, the City made address this shortfall by adopting a resolution approving the additional contribution in 2011 for 2010,

NOW THEREFORE, BE IT RESOLVED, the City Council of the City of Grand Rapids, Itasca County, Minnesota, authorizes the following operating transfer:

\$18,309 from the General Fund to the Special Revenue Fund-Library

Adopted this 11th day of April, 2011.

Dale Adams, Mayor

Attest:

Kim Johnson-Gibeau, City Clerk

Councilmember seconded the foregoing resolution and the following voted in favor thereof: ; and the following voted against same: None, whereby the resolution was declared duly passed and adopted.

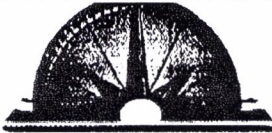

Arrowhead Library System

5528 Emerald Ave. • Mt. Iron, MN 55768-2069 • 218-741-3840 • www.arrowhead.lib.mn.us

March 14, 2011

Marcia Anderson, Director
Grand Rapids Area Library
140 Northeast 2nd Street
Grand Rapids, MN 55744-2826

Dear Marcia:

As we recently discussed over the telephone, the so-called "re-certification" process for your city's 2010 minimum level of local support resulted in some confusion as to the actual amount of financial support needing to be provided to the Grand Rapids Area Library.

A letter from State Library Services dated "Fall 2010" stated that the re-certified amount of local support was \$519,716. That amount reflects a 10% reduction as permitted in Statute resulting from the City of Grand Rapids' loss of state aid. You recently reported that the amount of local support received for the Grand Rapids Public Library in 2010 was actually \$501,407.

The shortfall in support from the City was \$18,309. As we discussed, it is still possible to address that shortfall in 2011. ALS would need a copy of a resolution or other proof of action by the Grand Rapids City Council that allocates the shortfall amount to the so-called "library fund." The funds used to address the shortfall can only be used as part of the City's 2010 level of local support and cannot be counted as part of 2011's minimum level of local support for the Library. ALS requests that such actions take place prior to June 1, 2011 in order to avert any actions by State Library Services that might negatively impact the Library's continued membership in the Arrowhead Library System.

If there is anything I can do to assist you in this process, or additional information that I can provide, please let me know.

Sincerely,

Jim Weikum
Executive Director

pc: Vicky Harding, ALS Governing Board
Shari Fisher, ALS
Rebecca Patton, ALS

Mission *The mission of the Arrowhead Library System is to deliver highly responsive and accessible library service to its member libraries and people of the region through a collaborative network of coordinated programs.*



CITY OF
GRAND RAPIDS
IT'S IN MINNESOTA'S NATURE

CITY OF GRAND RAPIDS

CITY COUNCIL CHAMBERS
420 NORTH POKEGAMA
AVE.

Legislation Details (With Text)

File #: 11-1448 **Version:** 1 **Name:** Board & Commission Minutes
Type: Agenda Item **Status:** Acknowledge
File created: 4/6/2011 **In control:** Administration
On agenda: 4/11/2011 **Final action:**
Title: Acknowledge minutes for Boards & Commissions.

Sponsors:

Indexes:

Code sections:

Attachments: [February 23, 2011 Human Rights Commission](#)
[February 24, 2011 GREDA](#)
[March 10, 2011 GREDA](#)

Date	Ver.	Action By	Action	Result
------	------	-----------	--------	--------

Title

Acknowledge minutes for Boards & Commissions.

**CITY OF GRAND RAPIDS HUMAN RIGHTS COMMISSION
REGULAR MEETING
CONFERENCE ROOM 2B – 420 NORTH POKEGAMA AVENUE
WEDNESDAY, FEBRUARY 23, 2011 – 4:00 P.M.**

CALL TO ORDER: Pursuant to due notice and call thereof a regular meeting of the Grand Rapids Human Rights Commission was held in Conference Room 2B of City Hall, 420 North Pokegama Avenue, Grand Rapids, Minnesota, on Wednesday, February 23, 2011, at 4:00 p.m.

CALL OF ROLL: On a Call of Roll, the following members were present: Commission Chair Wartchow, Commissioners: Downing, Freeman (arrived 4:07 p.m.) Hain, Hall, Learmont, Mundt (arrived 4:12 p.m.) and Sanderson. Absent: None.

Staff: Lynn DeGrio, Human Resources Director

The meeting was called to order at 4:03 p.m.

MOTION BY COMMISSIONER HAIN, SECOND BY COMMISSIONER DOWNING TO ADD THE MINUTES OF JANUARY 26, 2011 REGULAR MEETING TO THE AGENDA FOR APPROVAL. The following voted in favor thereof: Hain, Downing, Wartchow, Hall, Learmont and Sanderson. Opposed: None, motion carried.

MOTION BY COMMISSIONER DOWNING, SECOND BY COMMISSIONER SANDERSON TO ADD TO THE AGENDA DISCUSSION WITH MAYOR ADAMS, ED ZABINSKI AND COMMISSIONER HALL TO NEW BUSINESS. The following voted in favor thereof: Downing, Sanderson, Wartchow, Hain, Hall, Learmont and Sanderson. Opposed: None, motion carried.

APPROVAL OF MINUTES: January 26, 2011 regular meeting

TREASURERS REPORT:

Approval of invoices presented: None presented.

Budget update: (To be continued later in meeting.)

OLD BUSINESS:

Contact/Distribution List Update

Commissioners reviewed the Human Rights Commission Contact Distribution List 2011 distributed at the meeting. In addition to names collected, Commissioners added:

- IASC – see website
- ISD #318 – Superintendent’s Administrative Assistant
- Western Itasca Review (Human Resources Director DeGrio)
- Toni Wilcox – correct spelling of name Toni
- Leech Lake Reservation – contact: Arthur (Archie) LaRose
- Tribal Leader – Ball Club – contact: Robbie Howe-Bebeau

Chair Wartchow encouraged Commissioners to respond with additional names.

TREASURY REPORT (continued):

Budget Update:

Commissioners reviewed the budget for end-of-year 2010 and beginning 2011 as presented. Commissioners confirmed the following on the 2011 budget:

- \$3,000 Blandin Grant
- \$4,000 budget from City of Grand Rapids

OLD BUSINESS (continued):

Discussion – Election of Officers.

The Commission discussed the filling of Vice Chair, Secretary and Treasurer. Commissioners felt they could combine the Secretary and Treasurer position. The following motions were made:

MOTION BY COMMISSIONER FREEMAN, SECOND BY COMMISSIONER HAIN TO NOMINATE COMMISSIONER HALL AS VICE CHAIR. The following voted in favor thereof: Freeman, Hain, Wartchow, Downing, Hall, Learmont, Mundt and Sanderson. Opposed: None, motion carried.

MOTION BY COMMISSIONER SANDERSON SECOND BY COMMISSIONER FREEMAN TO NOMINATE COMMISSIONER MUNDT AS SECRETARY/TREASURER. The following voted in favor thereof: Sanderson, Freeman, Wartchow, Downing, Hain, Hall, Learmont and Mundt. Opposed: None, motion carried.

MOTION BY COMMISSIONER LEARMONT, SECOND BY COMMISSIONER DOWNING TO CLOSE THE NOMINATIONS. The

following voted in favor thereof: Learmont, Downing, Wartchow, Freeman, Hain, Hall, Mundt, and Sanderson. Opposed: None, motion carried.

Signing of By-Laws.

By-Laws were signed by Chair Wartchow and Secretary/Treasurer Mundt.

Update on the film “Bullied”.

Commissioner Mundt stated they now have six co-sponsors. The film will begin at 6:30 p.m. with the HRC video and then the movie “Bullied”. A small panel discussion will follow. Commissioner Sanderson was asked if she would facilitate the panel discussion to which she agreed. Commissioners Sanderson and Mundt both agreed Thursday, April 7, 2011 would be the best date for the event. Commission Chair Wartchow thanked Commissioner Mundt for being involved in the project.

ICC Update regarding Rapids Read.

Commissioner Freeman stated the English teachers at ICC were unable to make the discussion of “The Latecomer” work but the Library is open to having the speaker. Commission Chair Wartchow stated the Carleton alumni are trying to put together a dinner for the speaker.

Commissioner Sanderson reminded the Commission of the grant request to follow up after the event. Several suggestions were received:

1. Could invite a Hmong artist to exhibit and explain about the story cloth.
2. Farmer’s Market – Agriculture History
3. July Art Fair at MacRostie Art Center – sponsor a Hmong artist to show art and speak.
4. We have Farmer’s Market, University Extension Group, Master Gardeners and FFA at the High School.

Commissioners Sanderson, Learmont and Freeman will get more information on the Farmer’s Market to share with the Commission.

Kathleen Nuccio – update donation amount for fall program.

Commissioners have not heard back on proposed amount of donation.

Essar Steel Update.

Commissioner Learmont has contacted Essar Steel to speak to the Commission. They sound willing to come; however, this week was not convenient. The Commissioners would like notification of date and time when arrangements are made.

The following are suggestions from Commissioners:

1. Get feedback from Commission members to what we would like included in the presentation.
2. Presentation could be at night and open to the public.

3. Looking for collaborative effort between HRC and Essar Steel.

Commissioners expressed their appreciation for Commissioner Learmont's efforts.

Order Brochures:

Commissioner Sanderson requested clarification on who will be ordering the Islamic brochures approved from the last meeting. It was determined Commissioner Sanderson will order. The Commission thanked Commissioner Sanderson for her work.

NEW BUSINESS:

Discussion with Mayor Adams, Councilman Zabinski and Commissioner Hall.

Commissioner Hall stated the City Council would like the HRC to report to them a few times a year, addressing the City Council at their worksession. Human Resources Director DeGrio will inform the Commission when it would be a beneficial time to present to the Council.

REPORTS ON CALLS AND INQUIRIES:

None reported.

PENDING COMPLAINTS:

No further information at this time on the report from last month.

OTHER:

Human Resources Director DeGrio stated Assistant Chief Schaar would like to invite the Commission to the Citizen's Academy. The following four members shared their positive experiences: Human Resources Director DeGrio, Commissioners: Sanderson, Freeman and Hain. The invitations were emailed last week.

Commissioner Mundt received concerns from high school students. He referred them to appropriate organizations. Commissioner Hain recommended safe@isd318.org – a safe, anonymous place to report.

The Commission currently has one opening. Three Commissioners' terms are up and have interviewed with two City Council members: Mayor Adams and Councilman Zabinski. Commission Chair Wartchow complemented the Commission on 100 percent attendance.

Commission Chair Wartchow reminded Commissioners to put March 1 and 17 at 7:00 p.m. on their calendars to hear two speakers – Concordia Scholar on Hmong and author of “The Latecomer” respectively.

The next regularly scheduled meeting will be March 30, 2011 at 4:00 p.m. unless otherwise noted.

ADJOURN:

There being no further business the following motion was made to adjourn the meeting:

MOTION BY COMMISSIONER DOWNING SECOND BY COMMISSIONER FREEMAN TO ADJOURN THE MEETING AT 5:01 P.M. The following voted in favor thereof: Downing, Freeman, Wartchow, Hain, Hall, Learmont, Mundt and Sanderson. Opposed: None, motion carried.

Respectfully submitted,

Dawn Schaefer, Recorder

**GRAND RAPIDS ECONOMIC DEVELOPMENT AUTHORITY
REGULAR MEETING
THURSDAY, FEBRUARY 24, 2011
4:00 P.M.
GRAND RAPIDS CITY HALL – CONFERENCE ROOM 2A
420 NORTH POKEGAMA AVE., GRAND RAPIDS, MINNESOTA**

CALL TO ORDER: Pursuant to due notice and call thereof, a Regular Meeting of the Grand Rapids Economic Development Authority (GREDA) was called to order on Thursday, February 24, 2011 at 4:00 p.m. in Conference Room 2A of City Hall, 420 North Pokegama Avenue, Grand Rapids, Minnesota.

CALL OF ROLL: On a Call of Roll the following members were present: Commissioners: Chris Lynch, Ed Zabinski, Sholom Blake, Mike Przytarski. Absent: Commissioners: Marian Barcus, Sue Helmbrecht, Gary McInerney.

Staff present: Rob Mattei

SETTING OF REGULAR AGENDA: Approved with addition.

- Discussion regarding downtown redevelopment.

APPROVAL OF MINUTES:

MOTION BY COMMISSIONER BLAKE, SECOND BY COMMISSIONER LYNCH TO APPROVE THE MINUTES OF THE JANUARY 27, 2011 REGULAR MEETING. The following voted in favor thereof: Lynch, Przytarski, Zabinski, Blake. Opposed: None, passed unanimously.

APPROVAL OF CLAIMS:

MOTION BY COMMISSIONER LYNCH, SECOND BY COMMISSIONER BLAKE TO APPROVE CLAIMS IN THE AMOUNT OF \$11,896.92.

City of Grand Rapids	766.21	ICTV	5,465.29
Kent Nyberg Law Office LTD	4,708.50	White Ivy Graphic Arts	956.92

The following voted in favor thereof: Lynch, Blake, Przytarski, Zabinski. Opposed: None, passed unanimously.

Review and consider approval of a proposal for website development.

Community Development Director Mattei provided quotes from White Ivy Graphics and Liz Bonner. Mr. Mattei reviewed the proposals with the Commissioners and explained the charges for content and management training. Liz Bonner came in with the low quote at \$2,500.00 for the initial set up and two training sessions.

MOTION BY COMMISSIONER PRZYTARKSI, SECOND BY COMMISSIONER BLAKE TO APPROVE THE PROPOSAL FROM LIZ BONNER IN THE AMOUNT OF \$2,500.00 FOR THE GREDA WEBSITE DEVELOPMENT. The following roll call vote was taken: Yea: Przytarski, Lynch, Blake, Zabinski. Nay: None, passed unanimously.

Review applications for vacant seat on Mississippi Riverfront Committee.

Two applications were received for the vacant seat on the Mississippi Riverfront Committee. The two applicants were Steve Downing and Ashley Kolka. Mr. Mattei noted Steve Downing has been a regular attendee of the MRC Meetings.

MOTION BY COMMISSIONER PRZYTARSKI, SECOND BY COMMISSIONER LYNCH TO APPOINT STEVE DOWNING TO THE VACANT SEAT ON THE MISSISSIPPI RIVERFRONT COMMITTEE. The following roll call vote was taken: Yea: Blake, Lynch, Przytarski, Zabinski. Nay: None, passed unanimously.

Review and consider request for Northspan funding request.

Northspan is requesting \$2,500.00 from the GREDA for this years funding commitment, this is the same amount that was contributed by GREDA last year. Joe Broking, President IEDC, said they have committed \$2,500.00 to Northspan for 2011.

MOTION BY COMMISSIONER BLAKE, SECOND BY COMMISSIONER LYNCH TO CONTRIBUTE \$2,500.00 TO NORTHSPAN FOR 2011 FUNDING COMMITMENT. The following roll call vote was taken: Yea: Przytarski, Lynch, Blake, Zabinski. Nay: None, passed unanimously.

Joe Broking provided a brief update on the current status of some local projects. The Essar Steel project is moving ahead and IEDC is working with a possible anchor tenant for the IEIP.

Discuss downtown redevelopment.

In Duluth the Greater Downtown Council sponsored a contest for local businesses. The business with the best business plan won a years worth of free rent. The Commissioners thought this would be a good idea to try in Grand Rapids.

MOTION BY COMMISSIONER BLAKE, SECOND BY COMMISSIONER LYNCH TO AJOURN THE MEETING AT 5:00 P.M. The following voted in favor thereof: Zabinski, Przytarski, Lynch, Blake. Opposed: None, passed unanimously.

The next scheduled meeting is Thursday, March 10, 2011 at 4:00 p.m. unless otherwise noticed.

Respectfully submitted:

Aurimy Groom, Recorder

Presentation-Minnesota Rural Intelligent Communities (MIRC)-U or MN Extension Upcoming Training-Kathy Kooda.

The U of M extension office will be holding workshops to help local businesses compete globally.

Small Cities Development Program (SCDP) Commercial Rehabilitation Grant project status update.

Community Development Director reviewed the grant projects and provided before and after photos. Out of the six projects selected four have been completed.

Updates.

Community Development Director Mattei said the GREDA Website development is moving forward. GREDA directed staff to make the necessary decisions to complete the website.

MOTION BY COMMISSIONER MCINERNEY, SECOND BY COMMISSIONER BLAKE TO AJOURN THE MEETING AT 4:47 P.M. The following voted in favor thereof: Gullickson, Stefan, Zabinski, Przytarski, Lynch, Blake. Opposed: None, passed unanimously.

The next scheduled meeting is Thursday, March 24, 2011 at 4:00 p.m. unless otherwise noticed.

Respectfully submitted:

Aurimy Groom, Recorder



CITY OF
GRAND RAPIDS
 IT'S IN MINNESOTA'S NATURE

CITY OF GRAND RAPIDS

CITY COUNCIL CHAMBERS
 420 NORTH POKEGAMA
 AVE.

Legislation Details (With Text)

File #: 11-1451 **Version:** 1 **Name:**
Type: Agenda Item **Status:** Department Head Report
File created: 4/7/2011 **In control:** Administration
On agenda: 4/11/2011 **Final action:**
Title: Finance Department - Shirley Miller

Sponsors:

Indexes:

Code sections:

Attachments:

Date	Ver.	Action By	Action	Result
------	------	-----------	--------	--------

Title

Finance Department - Shirley Miller



CITY OF GRAND RAPIDS

CITY COUNCIL CHAMBERS
420 NORTH POKEGAMA
AVE.

Legislation Details (With Text)

File #:	11-1444	Version:	1	Name:	Reconviene Consideration of PUC-DRHH Text Amend.
Type:	Agenda Item	Status:			Community Development
File created:	4/6/2011	In control:			Community Development
On agenda:	4/11/2011	Final action:			
Title:	Reconvene consideration of the recommendation of the Planning Commission to adopt an Ordinance amending Section 30-512 Table-1 (Permitted Uses) of the Land Development Regulations that would add Recycling Center uses, as a permitted use, within the PU/SPU (Public Use/Shoreland Public Use) zoning district, and authorize its publication in summary form.				
Sponsors:					
Indexes:					
Code sections:					
Attachments:	Recycling Center Use in PU Text Amendment Ordinance 3-28-11 City Zoning Map FLU Map Final Draft-PUC Site March 28 2011 CC Regular Meeting Rezoning Considerations				

Date	Ver.	Action By	Action	Result
------	------	-----------	--------	--------

Title

Reconvene consideration of the recommendation of the Planning Commission to adopt an Ordinance amending Section 30-512 Table-1 (*Permitted Uses*) of the Land Development Regulations that would add Recycling Center uses, as a permitted use, within the PU/SPU (Public Use/Shoreland Public Use) zoning district, and authorize its publication in summary form.

Body

Background Information:

Following the public hearing on this matter on March 28, 2011, the City Council began its consideration of the petitioned request, the Planning Commission recommendation, the public testimony and the relationship between the request and the potential terms of a lease of the decommissioned dewatering building. The City Council decided they needed additional time to examine the facts before them and directed the City Attorney to review the general lease terms.

The City Council acted to table their consideration of the draft ordinance and also acted to extend the 60 Day Rule an additional 60 days to allow more time to render their decision.

The Council can accept the recommendation of the Planning Commission, if they are in agreement with it, or the Council can make its own findings to support its reasons for denying a text amendment as drafted. *Those findings would be incorporated into an ordinance for the affirmative amendment of the Zoning Ordinance and brought back to the Council at their next meeting for ratification.*

1. Will the change affect the character of the neighborhood?
2. Will the change foster economic growth in the community?

3. Would the proposed change be in keeping with the spirit and intent of the Zoning Ordinance?
4. Would the change be in the best interest of the general public?
5. Would the change be consistent with the Comprehensive Plan?

Requested City Council Action

Reconvene consideration of the recommendation of the Planning Commission to adopt an Ordinance amending Section 30-512 Table-1 (*Permitted Uses*) of the Land Development Regulations that would add Recycling Center uses, as a permitted use, within the PU/SPU (Public Use/Shoreland Public Use) zoning district, and authorize its publication in summary form.

ORDINANCE NO, 11-__

AN ORDINANCE TO AMEND SECTION 30-512 TABLE-1 (PERMITTED USES) AND SECTION 30-564 (USES WITH RESTRICTIONS) OF CHAPTER 30 (LAND DEVELOPMENT REGULATIONS), ARTICLE VI (ZONING) OF THE GRAND RAPIDS, MINNESOTA CITY CODE INVOLVING THE ADDITION OF RECYCLING CENTER USES AS PERMITTED USES WITH ADDITIONAL RESTRICTIONS WITHIN THE PU/SPU (PUBLIC/SHORELAND PUBLIC USE) ZONING DISTRICT

WHEREAS, the Planning Commission on March 3, 2011 reviewed petitioned draft amendments to Section 30-512 Table-1 of the Zoning Ordinance pertaining to Recycling Centers as permitted uses within PU/SPU zoned districts; and

WHEREAS, the Planning Commission modified the amendment request as described below and made certain findings of fact, that the addition of these provisions were consistent with the Comprehensive Plan and would be in the best interest of the public's health, safety, and general welfare, and recommended that the City Council adopt amendments to said portions of Article VI of Chapter 30 of the City Code; and

WHEREAS, the City Council conducted a public hearing on Monday, March 28, 2011 at 6:00 p.m., to consider the amendments; and

WHEREAS, the City Clerk presented the affidavit of publication of the notice of the public hearing; and

WHEREAS, the City Council has heard all persons who wished to be heard in regards to the proposed text amendments.

NOW, THEREFORE, BE IT RESOLVED BY THE CITY COUNCIL OF GRAND RAPIDS, MINNESOTA, that it adopts the Planning Commission's following findings of fact relative to the amendments to provisions within Section 30-512 Table-1 and Section 30-564, Article VI of Chapter 30 of the City Code:

- The amendments would have a minimal effect on the character of neighboring areas; traffic flow is the only potential change.
- The amendments would foster economic growth in the community by allowing additional employment opportunity for Deer River Hired Hands in this case and offering additional opportunities for future recycling operations.
- That the amendments would be in keeping with the spirit and intent of the Zoning Ordinance in that recycling centers with restrictions are similar in scope and public impact as outdoor storage and warehousing .
- That the amendments would be in the best interest of the general public by enhancing the opportunity for recycling within the greater Grand Rapids area.
- That the amendments would be consistent with the Comprehensive Plan, as this amendment is consistent with both the 2003 and pending revision to the Comprehensive Plan.

NOW, THEREFORE, BE IT FURTHER RESOLVED BY THE CITY COUNCIL OF GRAND RAPIDS, MINNESOTA: that the proposed amendments to the City Code are in the best interest of the public's health, safety, and general welfare, and hereby ordains that the Grand Rapids City Code be amended as follows:

Table 1, Section 30-512, Division 4, and Section 30-564, Division 6, of Article VI, and Chapter 30, of the Grand Rapids, Minnesota City Code is amended as follows:

**TABLE 1 - PERMITTED USES
TABLE INSET:**

																TRANSPORTATION		
												P	P			P	P	major (terminals, hangers, switching yards, sidings, runways, heliports)
	P	P	P	P	P	P	P	P	P			P	P	P	P	P	P	minor (railroad, rights-of-way, streets, transit shelters)
																INDUSTRIAL		
							P					P						monument work/sales
												P					P	military post
					R	R	R					P	P					manufacturing, custom (production and sale of handmade goods on the premises)
												P	P					manufacturing, heavy (fabricating, processing, assembly from raw or semifinished products)
												P	P					Light industrial activities not listed
												P	P					Heavy industrial activities not listed
							R					P				<u>R</u>		recycling center
							P					P	P					testing and research
					R	R	R					R	R					outdoor storage (merchandise/material)
C UP											CU P	CU P	CU P				C U P	mining of sand and gravel

Section 30-564 Uses with restrictions:

(36) Recycling center (within GB, SGB zone): All outdoor storage of equipment, except automobiles and trucks up to two ton, and materials/supplies shall be screened from public view as per the requirements of section 30-594(h).

(37) Recycling center (within PU/SPU zone):

a) All outdoor storage of equipment, except automobiles and trucks up to two ton, and materials/supplies shall be screened from public view as per the requirements of section 30-594(h).

b) Any processing and overnight storage of recyclable materials occur inside an enclosed structure.

(378) Restaurant (within the M, SM zone): Must be accessory to a permitted principal use; no sale of alcoholic beverages.

(389) Restaurant (within the RC, SRC zone): Must be accessory to a permitted principal use.

(3940) Retail--General sales and service (within the LB, SLB zone): Maximum size of structure shall be limited to 3,000 square feet gross floor area, and no more than 1,000 square feet GFA of retail sales space.

(401) Retail--General sales and service (within the AP zone): Shall be permitted to occupy up to 25 percent of the gross floor area in the main terminal building, and shall not have signs visible from the public street right-of-way.

(412) Roomers (within the RR, SRR, R-1, SR-1, R-1a, SR-1a, R-2, SR-2, AG zone): The leasing of rooms to not more than two roomers provided no signs are displayed, the rooms are not equipped with kitchen facilities of any kind and one on-site parking space is provided for each roomer in addition to the minimum number required for the residence.

(423) Satellite dishes and solar energy systems/collectors (within all zones): Provided they comply with the yard and height requirements for principal buildings. Where a rear yard abuts a lake or stream, satellite dishes and solar collectors shall not be permitted between the water body and the principal building.

(434) Schools--Elementary through secondary (within RR, SRR, R-1, SR-1, R-1a, SR-1a, R-2, SR-2, R-3, SR-3, R-4, SR-4 zone): Subject to the following:

a. Small schools within existing buildings: Schools for 25 or fewer students shall be permitted within the existing principal church or religious building provided that:

1. Alterations: There shall be no external alteration of the building(s) or grounds to reflect school usage.

2. Parking: There shall be sufficient parking within the existing parking lot to accommodate off-street parking as required by section 30-628.

b. Primary, middle or secondary schools:

1. Minimum site area: One acre.
2. Minimum yards: 30 feet from all R district lot lines or the minimum for the district, whichever is greater.
3. All other requirements of the zoning district are met.
4. The use shall be subject to the site development standards in article VI, division 7 of this chapter, and for bufferyard purposes shall be treated as an R-3 property.

(445) Shooting ranges (within RC zone): Subject to the following:

- a. All shooting ranges shall be subject to the standards set forth in Minnesota Statutes 87A, as may be amended.
- b. Shooting activities and discharge of firearms shall be limited to 7:00 a.m. to 10:00 p.m. daily.
- c. All shooting ranges shall comply with the minimum standards for range design, location, management, operation, noise abatement and safety listed in the National Rifle Association's Range Sourcebook, 1999; or successor sourcebook.
- d. No part of any shooting range may be located within 500 feet of any residential dwelling, commercial or industrial building or other structure used for human occupancy.
- e. There shall be no discharge of lead shot into any wetland.

(456) Senior Housing with Services (within RR, R-1 and R-2): Subject to the following:

- a. For 6 or fewer persons, said use shall be licensed by the State of Minnesota for 6 or fewer persons.
- b. For 7 – 8 persons, in situations when the area of the lot upon which the proposed use is to be located is equal to or less than 2 acres, the use will be considered as a conditional use, and, as such will require the issuance of a conditional use permit by the City.
- c. For 9 – 16 persons, the maximum density of the proposed use shall not exceed 4 persons per acre.

(467) Temporary buildings (within all zones): Incidental to construction work on the premises. Such buildings shall be removed upon completion or abandonment of such work or within the period of one year from the establishment of the building whichever is the lesser.

(478) Temporary outdoor sales (within GB, SGB, CBD, MU, SMU, PU, SPU zone): Subject to all of the following:

- a. The sale is conducted by the owner or lessee of the premises, or with his written permission.
- b. The sale is no longer than four months in duration.
- c. The setbacks for a parking lot in that district shall be met for the storage and display of all merchandise and equipment used for the

sale.

- d. One sign shall be permitted per vendor, with a maximum size of 16 square feet (four feet by four feet). Such sign may contain up to two sides. Off-premises signs shall not be permitted.
- e. Parking demand shall be sufficiently met. If the use of parking spaces by the temporary outdoor sales results in insufficient parking for the area, the temporary outdoor sales area must be reduced to ensure sufficient parking supply.

(489) Vending machines (within LB, SLB, GB, SGB, CBD, MU, SMU, M, SM, SRC, I-1, SI-1, I-2, SI-2, PU, SPU, AP zone): Subject to the following:

- a. Must be accessory to a permitted principal use.
- b. Must conform to setback requirements of principal structure.
- c. Must be located adjacent to principal structure.

(4950) Vet clinic (within CBD zone): Limited to domestic animals only.

(501) Vet clinic (within I-1, SI-1 zone): All animals shall be housed indoors.

(512) Video arcades (within GB, SGB, and CBD zone): Subject to the following:

- a. Any arcade with 15 or more machines shall have an adult supervisor on the premises during all hours of operation.
- b. No arcade shall be operated within 500 feet of a school, church or residence.

(523) Warehouse--General (within PU, SPU zone): Limited to the indoor storage of private recreational vehicles. Warehouse space shall not be leased, rented or sold for commercial purposes or uses.

(534) Woodpiles: Subject to the same restrictions as subsection (289) of this section.

This Ordinance shall become effective after its passage and publication.

ADOPTED AND PASSED BY THE City Council of the City of Grand Rapids on the 28th day of March, 2011

Dale Adams, Mayor

Attest:

Kim Johnson-Gibeau, City Clerk

Councilmember _____ seconded the foregoing ordinance and the following voted in favor thereof: _____. Opposed: _____, whereby the ordinance was declared duly passed and adopted.

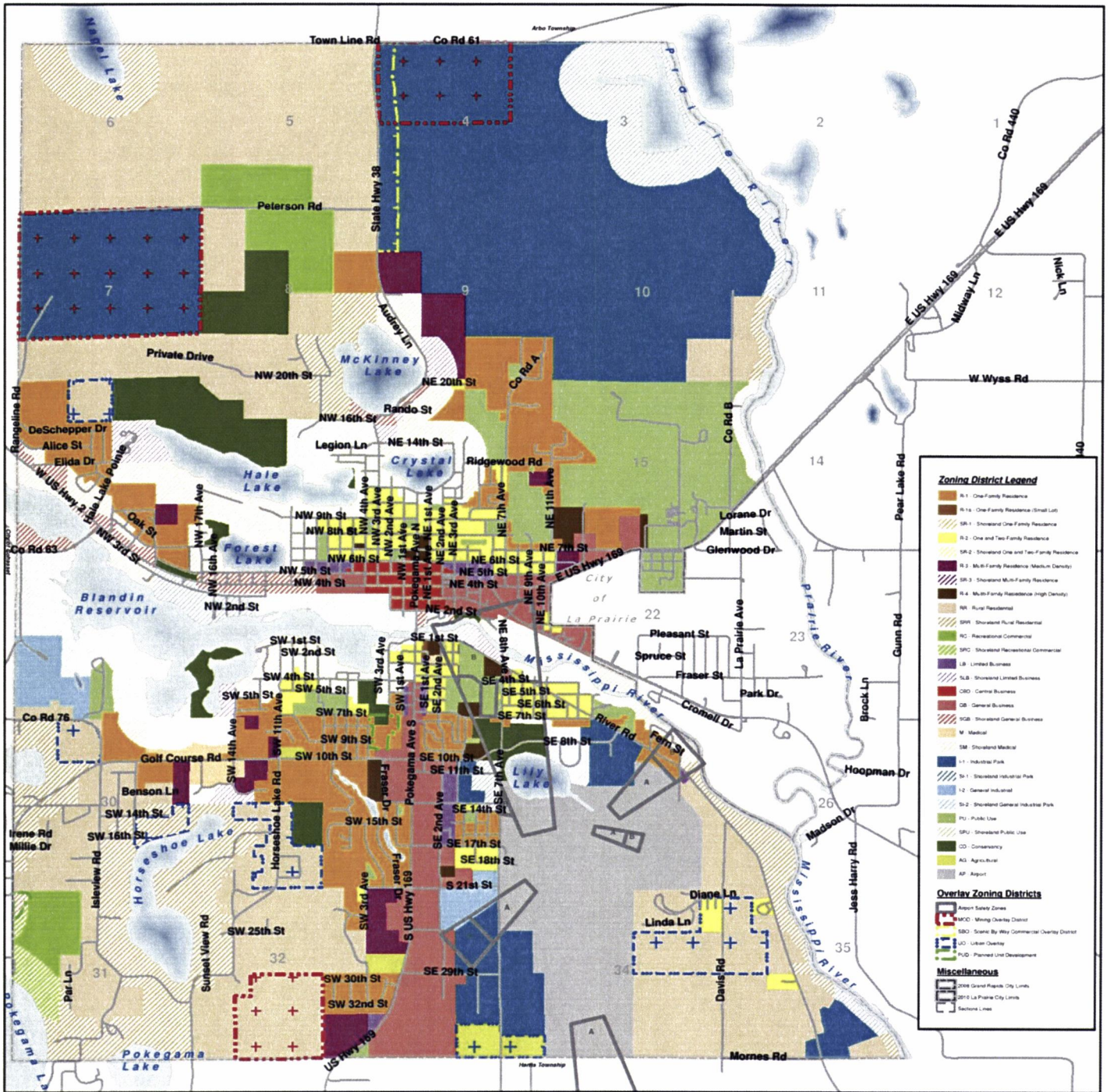

Zoning District Legend

- R-1 One Family Residence
- R-1A One Family Residence (Small Lot)
- SR-1 Shared One Family Residence
- R-2 One and Two Family Residence
- SR-2 Shared One and Two Family Residence
- SR-3 Shared Multi-Family Residence
- SR-4 Multi-Family Residence (High Density)
- NR Rural Residential
- SRP Shared Rural Residential
- RC Recreational Commercial
- SRP Shared Recreational Commercial
- LB Limited Business
- SLB Shared Limited Business
- COB Office Business
- GB General Business
- YGB Shared General Business
- W Medical
- SM Shared Medical
- I-1 Industrial Park
- SI-1 Shared Industrial Park
- I-2 General Industrial
- SI-2 Shared General Industrial Park
- PU Public Use
- SPU Shared Public Use
- CO-1 Conveyance
- AG-1 Agriculture
- AP Airport

Overlay Zoning Districts

- ASD Airport Safety Zones
- MDC-1 Mending Overlay District
- SBO-1 Scenic By Way Commercial Overlay District
- LUO-1 Urban Overlay
- PLD Planned Land Development

Miscellaneous

- 2008 Grand Rapids City Limits
- 2010 La Prairie City Limits
- Section Lines

COPY
 Official Map is located in the office of the Zoning Administrator,
 Located at Grand Rapids City Hall, 420 N Pokegama Ave
 For questions please call (218).326.7601

City of Grand Rapids Official Zoning Map



This document is the property of the City of Grand Rapids, Minnesota. It is to be used for informational purposes only. It is not to be reproduced, stored in a retrieval system, or transmitted in any form or by any means, electronic, mechanical, photocopying, recording, or by any information storage and retrieval system, without the prior written permission of the City of Grand Rapids. The City of Grand Rapids is not responsible for any errors or omissions in this document. The City of Grand Rapids is not responsible for any actions taken based on this document. The City of Grand Rapids is not responsible for any damages, including consequential damages, arising from the use of this document. The City of Grand Rapids is not responsible for any actions taken based on this document. The City of Grand Rapids is not responsible for any damages, including consequential damages, arising from the use of this document.

Grand Rapids Comprehensive Plan

Future Land Use

DRAFT

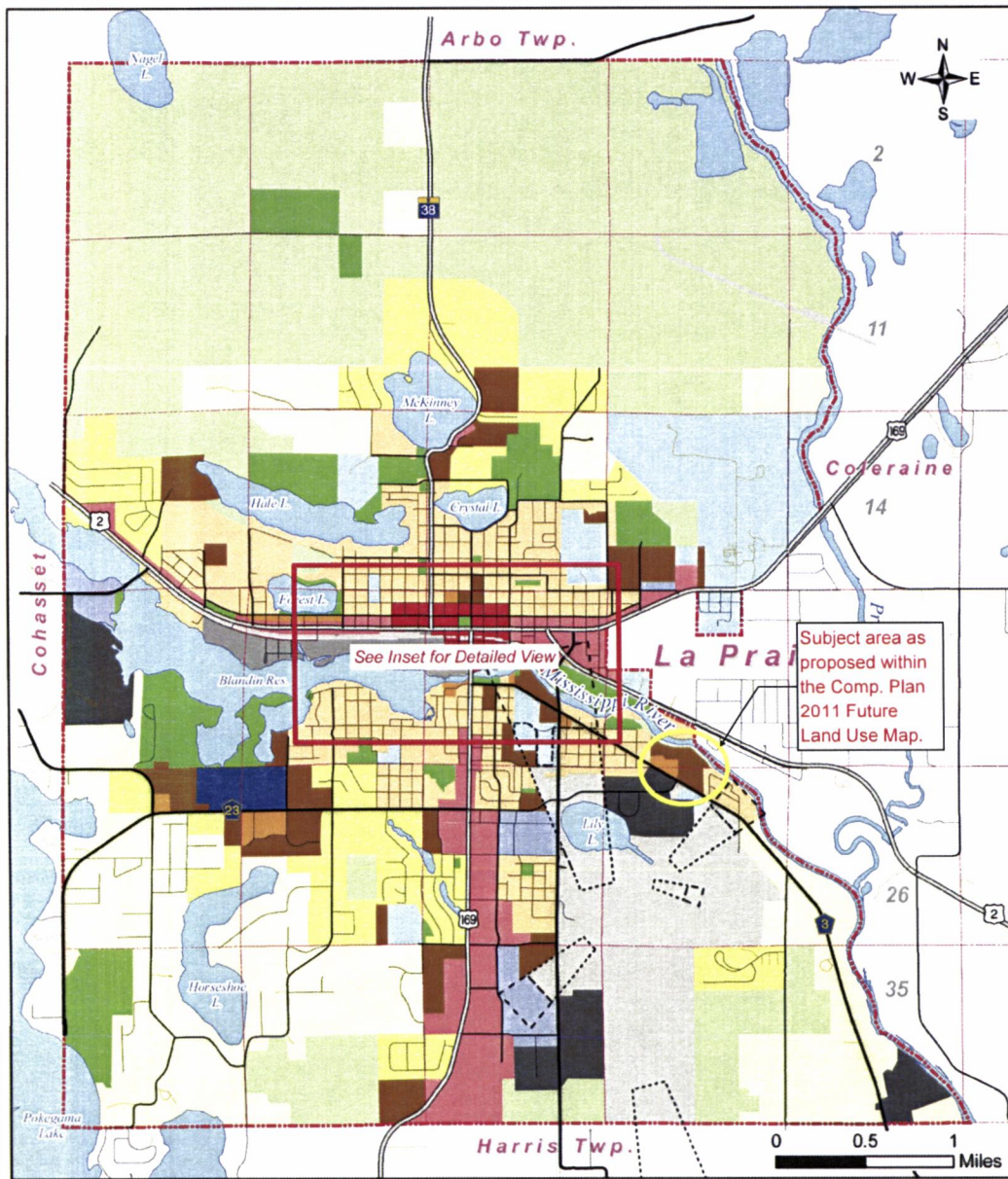

- | | | |
|--------------------------|----------------------------|----------------------------|
| Highway Commercial | Parks & Recreation | City Limits 2010 |
| Downtown Mixed Use | Resource Management | Open Water |
| Neighborhood Mixed Use | Rural Residential | Airport Zones |
| Industrial - Traditional | Suburban Residential | A |
| Industrial Park | Traditional Neighborhood | B |
| Business Park | Multi-Family Residential | Sections |
| Institutional/Civic | Transportation & Utilities | 2 4 Section Numbers |
| Medical Campus | | |

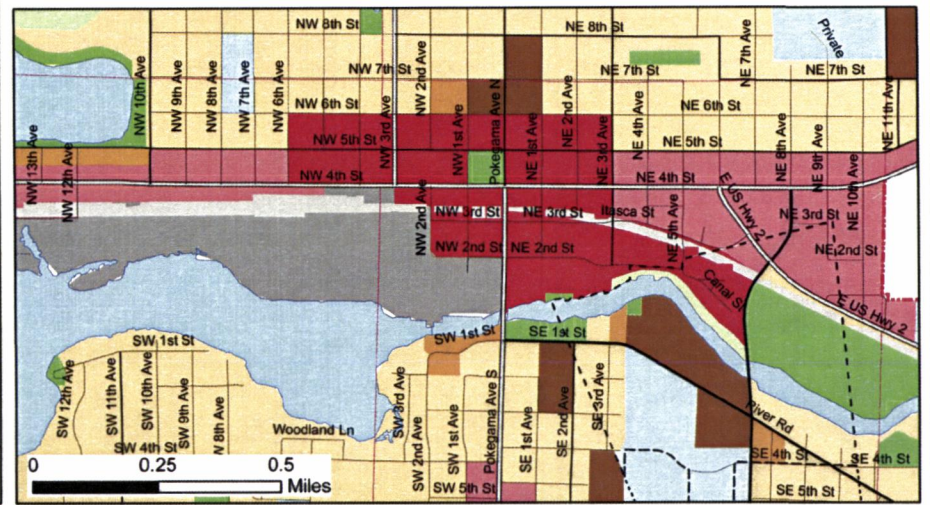

Map date: December 31, 2010. Data sources: City of Grand Rapids, MN, Mn/DOT, CR Planning



CITY OF GRAND RAPIDS

CITY COUNCIL
CHAMBERS
420 NORTH POKEGAMA
AVE.

Minutes - Final - Draft City Council

Monday, March 28, 2011

5:00 PM

City Hall Council Chambers

5:00 CALL TO ORDER: Pursuant to due notice and call thereof a Regular Meeting of the
p.m. Grand Rapids City Council was held on Monday, March 28, 2011 at 5:00 p.m. in
Council Chambers, 420 North Pokegama Avenue, Grand Rapids, Minnesota.

5:01 CALL OF ROLL: On a call of roll, the following members were present:
p.m.

Present 4 -

Councilor Gary McInerney, Councilor Dale Christy, Councilor Ed Zabinski,
and Mayor Dale Adams

Absent 1 -

Councilor Joe Chandler

5:02 MEETING PROTOCOL POLICY
p.m.

5:03 PUBLIC FORUM
p.m.

5:10 COUNCIL REPORTS
p.m.

Councilor Zabinski addresses the Council regarding City role in the animal shelter. City Administrator Gillen explains the situation with the humane society and the possibility of that facility closing, though this has not been decided as yet. The City will continue to try to collaborate with surrounding communities to manage the unclaimed animal population. Advise residents to call County Commissioner and the humane society.

Mayor Adams discusses recent Mayors and Managers Meeting which included a GIS presentation to introduce ideas for sharing resources that will help control costs for the City and surrounding communities.

5:12 APPROVAL OF MINUTES
p.m.

Approve minutes for March 14, 2011 at 4:00 p.m. and 5:24 p.m. and Special meeting on March 7, 2011.

A motion was made by Councilor Gary McInerney, seconded by Councilor Dale Christy to approve Council minutes as presented. The motion PASSED by an unanimous vote.

5:13 **CONSENT AGENDA**
p.m.

A motion was made by Councilor Christy, seconded by Councilor McInerney to approve items 1 through 22 and additional items 22a and 22b on the Consent Agenda. The motion carried by the following vote.

Aye 4 -

Councilor Gary McInerney, Councilor Dale Christy, Councilor Ed Zabinski, and Mayor Dale Adams

1. Approve list of Pokegama GC Seasonal Employees
2. Revision of the City of Grand Rapids Communications Policy.
3. Replace lighting fixtures at the IRA Civic Center.
4. Copier Contract Extension
5. Approve hiring temporary Park and Recreation Employees
6. Request by the Police Department to hold an auction and sell impounded and forfeited vehicles.
7. Request by the Police Department to hold an auction to sell old radios from the old radio system.
8. Schedule a public hearing for April 11, 2011 at 6:00 p.m. to receive public input as it pertains to the issuance of a new on-sale and Sunday liquor license for Toivo's, located at 1212 NW 4th Street, Grand Rapids, MN.
9. Consider approving Itasca County classification of tax-forfeited land.
10. Change Order 3 related to CP 2004-2B, TH Multi-Use Trail
11. A DNR Legacy Trail Grant related to CP 2011-4, Horseshoe-Isleview Reconditioning Project
Adopted resolution 11-36 - approving submittal of MN DNR Trail Legacy Grant Horseshoe-Isleview Trail CP 2011-4
12. A Service Order for GIS Services between the City and GRPUC
13. Receive feasibility report and call for a public hearing on CP 2011-4, Horseshoe-Isleview Reconditioning Project.
Adopted resolution 11-37 - receiving the report and calling for a hearing for

Horseshoe-Isleview Partial Reconditioning CP 2011-4.

14. A resolution receiving the feasibility report and calling for a public hearing on CP 2014-1, 1st Avenue NE Reconstruction.
Adopted resolution 11-38 - receiving the report and calling for a hearing for 1st Avenue NE reconstruction CP 2014-1
15. Completion of Introductory Period for John Nalan, Library Clerk II - Circulation.
16. Completion of Introductory Period for Assistant Chief Steven Schaar.
17. Approve plans and specifications and order the advertisement for bids on CP 2010-3, 19th Avenue NW Rail Crossing Improvements/Closures.
Adopted resolution 11-39 - to approve plans and specifications and order advertisement for bids for 19th Avenue NW rail crossing improvements/closures CP 2010-3
18. Approve the General Liability insurance coverage through the League of Minnesota Cities Insurance Trust for the 2011 plan year and authorize payment of the insurance premium including the agent fee.
19. Extended Medical Leave for William Block.
20. Approve Consumption and Display permit for Itasca County Curling Club.
21. Approve new lease for Central School with Ken Wagner, Barry Nelson and Jeff Argir dba Whispering Woods Gallery.
22. Change to Personnel Policy Manual Section 3.19 Job related media inquiries.
- 22a. Leave of absence request for William Olson, Firefighter.
- 22b. In conjunction with the American Society of News Editors "National Sunshine Week", the Grand Rapids City Council hereby endorse the concept of openness in government. The City Council of Grand Rapids has abided by the Minnesota Open Meeting Law since its inception, and we are proud of our track record in being open with all of our meetings and public information.

5:18 SETTING OF REGULAR AGENDA
p.m.

A motion was made by Councilor Ed Zabinski, seconded by Councilor Dale Christy, to approve the regular agenda as presented. The motion PASSED by an unanimous vote.

5:19 ACKNOWLEDGE BOARDS & COMMISSIONS
p.m.

23. Acknowledge minutes for Boards & Commissions.

Acknowledged minutes from the following:

*February 8, 2011 Airport Commission
February 8, 2011 Police Civil Service
February 9, 2011 Library Board
February 15, 2011 Golf Board
February 17, 2011 Central School
February 24, 2011 Police Civil Service Special Meeting*

5:20 DEPARTMENT HEAD REPORT

p.m.

24. Public Works Department Head Report

Received and Filed

5:30 CIVIC CENTER, PARKS & RECREATION

p.m.

25. Fishing Pier

A motion was made by Councilor Christy, seconded by Councilor McInerney to approve agreement with the State of Minnesota to construct a public fishing pier at Sylvan Park on the Mississippi River. The motion carried by the following vote.

Aye 4 -

Councilor Gary McInerney, Councilor Dale Christy, Councilor Ed Zabinski, and Mayor Dale Adams

5:35 ADMINISTRATION DEPARTMENT

p.m.

26. Appointment of Mr. Marty Brink to the position of Public Works Maintenance I and creation of one-year eligibility list.

A motion was made by Councilor McInerney, seconded by Councilor Christy to appoint Marty Brink to the position of Public Works Maintenance I and create a one year eligibility list. The motion carried by the following vote.

Aye 4 -

Councilor Gary McInerney, Councilor Dale Christy, Councilor Ed Zabinski, and Mayor Dale Adams

27. Review the Request for Proposal (RFP) seeking consultant services in the preparation of an updated Compensation Study, and authorize staff to issue the RFP for responses.

A motion was made by Councilor Ed Zabinski, seconded by Councilor Dale Christy to authorize staff to issue request for proposals for consultant services

in the preparation of an updated Compensation Study. The motion PASSED by an unanimous vote.

5:45 VERIFIED CLAIMS
p.m.

28. Consider approving the verified claims for the period March 8, 2011 to March 21, 2011 in the total amount of \$586,328.73.

A motion was made by Councilor Zabinski, seconded by Councilor McInerney to approve the verified claims as presented. The motion carried by the following vote.

Aye 4 -

Councilor Gary McInerney, Councilor Dale Christy, Councilor Ed Zabinski, and Mayor Dale Adams

7:50 PRESENTATIONS
p.m.

35. Annual Storm Water Utility Presentation

Received and Filed

Recess regular meeting for 1st public hearing scheduled for 6:00 p.m.

Recess regular meeting at 5:57 p.m. for public hearing at 6:00 p.m.

6:00 PUBLIC HEARINGS
p.m.

29. Conduct a public hearing to receive public input as it pertains to a temporary liquor license for the Boundary Waters Blues Festival and request for special consideration regarding excessive noise after 10:00 p.m. within the city limits, event to be held June 23-26, 2011 at the Itasca County Fairgrounds.

Background information is presented to the Council with specific requests for event hours.

A motion was made by Councilor McInerney, seconded by Councilor Christy to open the public hearing. The motion passed unanimously.

No one wished to speak, therefore the following motion was made.

A motion was made by Councilor McInerney, seconded by Councilor Zabinski to close the public hearing. The motion passed unanimously.

6:15 Reconvene regular meeting.
p.m.

30. Consider approving a temporary liquor license for the Boundary Waters Blues Festival for June 23, 2011 through June 26, 2011 located at the Itasca County

Fairgrounds and grant special consideration regarding excessive noise after 10:00 p.m.

A motion was made by Councilor Christy, seconded by Councilor Zabinski to approve the temporary on-sale liquor license for the Boundary Waters Blues Festival pending receipt of insurance and fees and to grant special consideration as it pertains to excessive noise after 10:00 p.m. The motion carried by the following vote.

Aye 4 -

Councilor Gary McInerney, Councilor Dale Christy, Councilor Ed Zabinski, and Mayor Dale Adams

**6:30 Recess regular meeting for 2nd public hearing.
p.m.**

31.

Conduct a public hearing to consider the rezoning of 1 acre of land from R-1 (One-Family Residential) to LB (Limited Business) located within east half of Block 26, Central Division of Grand Rapids.

Community Development Director Rob Mattei presents background information regarding request to rezone, location and current zoning.

A motion made by Councilor Zabinski, seconded by Councilor McInerney to open the public hearing. The motion passed unanimously.

Pastor Lynn Ronsberg, 169 Hwy , Grand Rapids - provides information regarding Grace House residence within the Zion Lutheran Church. Pastor Ronsberg states it has been an honor and privilege to share a home with Grace House.

Jill Shubert, 2105 Elm Street, Grand Rapids. Previous director of Grace House. Discusses volume of families/individuals served. Most had never been homeless before. At least 50% have changed their lives by getting assistance in finding employment and permanent housing.

Rick Hocking, 418 SW 2nd Ave, Grand Rapids. Object to the rezoning of the subject property. Located 350 feet from our home and do not wish to have this "caliber" of individuals in our neighborhood. Most are alcoholics and drug addicts.

Dan Hess, 20190 Happy Hollow Road, Grand Rapids. Crisis Management worker in Itasca County. In favor of the rezone. There have been no incidents involving placement of individuals in the housing facilities nor at Grace House.

Randall Carlson, 36104 Wabana Road, Veteran's Services. The Grace House has assisted many veterans. This provides a much needed humanitarian service.

Vicki Andrews, Grace House Board Member. Speaks in support of Grace House, reviewing the volunteers and the schedule. The people using Grace House are ordinary people that have fallen on hard times.

Dawn Stoll, 112 SW 6th Street, lives across the street from the proposed rezone property. Fear for safety. What about the people who are turned away and remain in the neighborhood. What sort of individuals will start coming into the neighborhood. Rarely see police presence in the neighborhood. Against the rezoning of this piece of property.

Annette Budrow, 4th Street, Grand Rapids. Against the rezone. Thinks Grace House is a great project but does not believe this project should be in a residential area. Suggests placing Grace House near the IRC building where these people can get to the soup kitchen and find work. All for Grace House but not in her backyard.

Jim Martinetto, 1507 SW 3rd Avenue, Board of Director of Hope House. No correlation in crime rate when you introduce one of these facilities into a neighborhood. This is not a flop house for drunks, sexual predators or other criminals. Homelessness is not a crime. This is a needed service and does not believe this will inflate the crime in the Southwest area. Recommend approval because this is a needed facility.

Kathy Wettersten, 4th Street, Grand Rapids, does not believe those present think that Grace House is a bad place. Hard time believing that this is the only place that the Grace House can relocate. Not worried about the people who escape the system. Shouldn't put a business in the neighborhood. Increased traffic. Ms. Wettersten reads letter that was presented to the Council as attachment to public hearing.

Bob Wagner, 715 SW 2nd Avenue, volunteer for Grace House. There is no reason to fear the people utilizing Grace House.

Lisa Hain, 712 NW 6th Avenue, Grand Rapids. Speaking in support for this opportunity for Grace House. Never had a concern about a Grace House guest.

Doug Veit, rural Grand Rapids resident. Would like to help others feel better about the people staying at the Grace House. We are all just one accident or one decision in life from losing everything. It could be any one of us. Supporting rezone.

Pat Medure, Grand Rapids, states that fear creates anxiety and we need to look at the past examples of Grace House. Calls for service to PD can happen in any neighborhood and are not specific to homes like Grace House.

Norene Haatula, 1104 SE 4th Street, discusses the fear factor. 1 in 4 people have mental illness and that may speak to the fear of people at Grace House. Most sexual assaults, molestation are perpetrated by people known to the victims. How many of the people at Grace House are children? Statistics don't lie. You can research this issue. Speaking in support of rezone for Grace House.

Marva Jean Hutchins, 3105 SW 3rd Avenue, thanks Zion for their hospitality. This is an opportunity to build relationships with the community and collaboration of neighborhoods. This can be a win win to build stronger partnership.

Nancy Alfuth, 4th St & 5th Avenue SW, did not sign petition. In favor of rezone for Grace House with no fear. Strongly believe they need a permanent home.

Teresa, guest of Grace House. Is grateful for assistance. Is now employed. Looking at a permanent home. I am not a criminal, just a person who had hard luck.

Jake Mutchler, Southwest neighborhood, has children who ride bikes in neighborhood. These people are strangers. Not good for the neighborhood, not good for property and should not be in the residential neighborhood.

Mary Ruby, Sunny Beach Road, Grand Rapids. Volunteers at Grace House and has never felt unsafe. Happy that the Grace House has the opportunity to purchase the property and never heard anything bad about Grace House.

Jan Streeter, 7th Avenue SE, would like to represent other neighborhoods. Thinks the Grace House is a great place. Asks the Council to listen to the neighbors. If this was in my neighborhood, I would want you to listen to me.

Heidi, staying at Grace House. Appreciates Grace House. They have helped with a place to sleep and shower. Working on finding employment, housing and are grateful for the assistance.

Fred Roldan, member of Johavoh Witness Church currently located on this property. aware of dangers that can come to the community. Many times have called the police due to vandalism. Vandalism stopped when there were more people around the property. There were times when they had trouble with the kids in the neighborhood. In favor of Grace House moving in.

Linda Hollenbeck, SW 2nd Avenue, would not have purchased her house in this neighborhood had she known there would be a homeless shelter there. Will there be people sleeping out on the property? Will they be loitering and hanging around looking for someplace else to stay if they can't get in to Grace House? Against the rezone.

Kathy Solem, President of Zion Lutheran Church Council, states that this organization would not have lasted in the church for this long if there had been issues. Grace House has been wonderful tenants and there is no reason to fear.

Mary Kay Jacobson, Zion Lutheran Church Council. Grace House deserves a place where they don't have to leave on Sundays. Aren't forced out over the holidays with no place else to go. Highly recommend that the Council approve the zoning change requested.

Diane Larson, 2521 Timberline Drive, HRA. On behalf of HRA, there is not enough affordable housing in our community. Worked with Grace House staff and they are well trained. As a member of Zion, the same concerns expressed when Grace House moved into Zion. Live one block west of the Church and there has been absolutely no problems that can be attributed Grace House.

Kathy Vassen, Grand Rapids, is volunteer coordinator at Grace House. The staff are trained well and are held accountable. Policy and procedure is strictly followed. Background checks are run and a very long intake interview.

Audrey Moen, LaPrairie, would have no concern for Grace House coming into her neighborhood.

Annette Budrow, stresses that she is a spiritual person and a compassionate person. This is our neighborhood, our block, and the people in the neighborhood do not want this.

Jim Martinetto, points out that there is limited business right across the street from the subject project. If they had purchased property across the street, this would not be an issue for public hearing.

Dawn Stoll, lives across the street from subject property. What about people that are turned away? Where do they go? Do they stay in the neighborhood, do they leave and come back drunk or using drugs. Grace House does not run drug tests on individuals asking for shelter.

No one else wished to speak, therefore the following motion was made.

A motion was made by Councilor Zabinski, seconded by Councilor McInerney to close the public hearing. The motion passed unanimously.

Mr. Mattei advises the Council that he prepared draft ordinance based on Planning Commission recommendations. Findings of fact of Planning Commission are included.

7:00 Reconvene regular meeting.

p.m.

32.

Consider the recommendation of the Planning Commission regarding adoption of an ordinance amending the Official Zoning Map by rezoning Lots 1-12, Blk. 26, Central Division of Grand Rapids from the established R-1 (One-family Residential) zoning to LB (Limited Business) zoning.

A motion was made by Councilor Zabinski, seconded by Councilor Christy to adopt Ordinance 11-03-02 - amending the Official Zoning Map by rezoning Lots 1-12, Blk. 26, Central Division of Grand Rapids from the established R-1 (One-family Residential) zoning to LB (Limited Business) zoning. The motion carried by the following vote.

Aye 4 -

Councilor Gary McInerney, Councilor Dale Christy, Councilor Ed Zabinski, and Mayor Dale Adams

7:10 Recess regular meeting for 3rd public hearing.

p.m.

33.

Conduct a Public Hearing to consider the adoption of an Ordinance amending Section 30-512 Table-1 (*Permitted Uses*) of the Land Development Regulations that would add Recycling Center uses, as a permitted use, within the PU/SPU (Public Use/Shoreland Public Use) zoning district.

Community Development Director Mattei provides background information regarding Deer River Hired Hands request to operate a recycling center at the old waste water treatment facility on River Road.

A motion was made by Councilor McInerney, seconded by Councilor Zabinski to open the public hearing. The motion passed unanimously.

Lonnie Aultman, 5th Street, concerned about the smell. Has been very happy that the sewage plant is moving out, but does not believe that the problem will be gone as recycling is a process that creates a strong odor.

Mono Sjostrand, 522 SE 14th Avenue, put up with the smell for 31 years. The noise from trucks, and what not have been a problem also. There are other facilities at the fairgrounds that could be rezoned. Would prefer that a lease be shortterm and re-evaluate regularly. If people drop recyclables at the gate, this material will wind up in the neighborhood yards, the river and the streets. Find another place.

Steve Oleseiser, 1403 SE 5th Street, lived in home for 51 years, with major remodeling in the last few years. What will come in next if this does not work? There are better areas in the community for recycling.

Judy Schroader, 2022 River Road, Support recycling center in Grand Rapids. This has been a great benefit for the employees of Deer River Hired Hands. Provide a very good service.

Shawn Linder, 502 14th Avenue SE, these facilities are noisy and there is an odor. Opposed to having the recycling center in this location.

Dean Singsank, customer and father of employee at Deer River Hired Hands. Created jobs for this community. Supports this text amendent.

Peter McDermott, MDI, speaking in support of Deer River Hired Hands and the proposed recycling center in Grand Rapids.

Davin Tinquist, resident of Cohasset, County Commissioner. Supporting the facts for Deer River Hired Hands. Kept very clean and there is not a strong odor leaking into the community. Never received complaints regarding the recycling center.

Mary Kay Jacobson, speaks in support of Deer River Hired Hands.

Shawn Burgraff, 1817 River Road, strong smell from sewage plant. Speaking against the placement of recycling center. Recommends that industrial size recycling bins can be utilized around the community or set in the industrial park where residents can drop off recycling and then have it hauled to Deer River.

Rodney Wood, 715 NW 9th Street, speaks in support of Deer River Hired Hands locating in this area.

Bob Gardner, president of Deer River Hired Hands. This facility is currently in a residential area in Deer River, and there have been no problems, no smell, no noise. Concerns expressed have never been an issue. Mr. Gardner urges Council to support this request.

Duane ?, Sunny Beach Road, uses Deer River Hired Hands recycling and supports the new site.

Shawn Linder, points out that Waste Management offers recycling. Questions the fee for rental and if the property was open for rent to everyone or just Deer River Hired Hands.

Steve Oleheiser, not against creating jobs in Grand Rapids, this effects other neighborhoods, and concerned about \$1 a year lease as a tax payer.

Mono Sjostrand, states that she too would like to rent the building for low cost. Concerns about traffic and noise created by excessive traffic. Believes that Deer River Hired Hands is a great business, but does not want this facility in their backyard.

No one else wished to speak, therefore the following motion was made.

A motion by Councilor McInenery, seconded by Councilor Christy to close the public hearing. The motion passed unanimously.

**7:40 Reconvene regular meeting.
p.m.**

34.

Consider the recommendation of the Planning Commission to adopt an Ordinance amending Section 30-512 Table-1 (*Permitted Uses*) of the Land Development Regulations that would add Recycling Center uses, as a permitted use, within the PU/SPU (Public Use/Shoreland Public Use) zoning district, and authorize its publication in summary form.

Staff answers questions regarding lease amount, time frame for removal of tanks, if and when, lessee responsible for insurance and maintenance of facility.

A motion by Councilor Christy, seconded by Councilor Zabinski to extend the 60 day rule for another 60 days and direct staff to make notification in writing. The motion passed unanimously.

A motion was made by Councilor Ed Zabinski, seconded by Councilor Gary McInerney, to table this item. The motion PASSED by an unanimous vote.

8:00 ADJOURNMENT
p.m.

There being no further business, the meeting adjourned at 9:38 p.m.

Respectfully submitted:

Kimberly Johnson-Gibeau, City Clerk

PLANNING COMMISSION

Considerations

ZONING ORDINANCE

1. Will the change affect the character of neighborhoods?
2. Would the change foster economic growth in the community?
3. Would the proposed change be in keeping with the spirit and intent of the ordinance?
4. Would the change be in the best interest of the general public?
5. Would the change be consistent with the Comprehensive Plan?

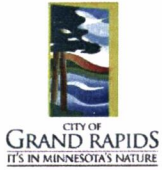

Legislation Details (With Text)

File #: 11-1429 **Version:** 1 **Name:**

Type: Agenda Item **Status:** Police

File created: 3/31/2011 **In control:** Police

On agenda: 4/11/2011 **Final action:**

Title: Request by the Grand Rapids Police Department to trade radios from the old radio system to Hibbing Community College in exchange for a reduced cost to our training they charge us.

Sponsors:

Indexes:

Code sections:

Attachments:

Date	Ver.	Action By	Action	Result
------	------	-----------	--------	--------

Title

Request by the Grand Rapids Police Department to trade radios from the old radio system to Hibbing Community College in exchange for a reduced cost to our training they charge us.

Background Information:

The Grand Rapids Police Department in the past has traded old out-dated Police equipment to the Hibbing Community College Law Enforcement Program, in exchange they charge us less the following year for our yearly training expenses. This year we we would like to trade 3 old car radios, which are from the old radio system, to Hibbing Community College Law Enforcement Program in exchange for a reduced cost to our training budget for the year 2012. The old car radios are valued at between \$150.00 and \$200 a piece. Hibbing Community College has agreed to pay \$200.00 per radio.

RADIOS:

Motorola Radius GM300 car radio
Model# M43GMC29C2AA
Serial# 159WAC340

Motorola Max Trac 300 car radio
Model# D33MJA7DA5CK
Serial# 428TZA2548

Motorola Max Trac car radio
Model# D43MJA7JA5AK
Serial# 428TZA2548

Requested City Council Action

Request by the Grand Rapids Police Department to trade radios from the old radio system to Hibbing Community College in exchange for a reduced cost to our training they charge us.

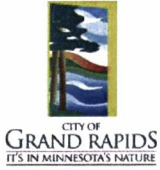

Legislation Details (With Text)

File #: 11-1439 **Version:** 1 **Name:**

Type: Agenda Item **Status:** Public Hearing

File created: 4/5/2011 **In control:** Administration

On agenda: 4/11/2011 **Final action:**

Title: Conduct a public hearing to receive public input on granting an On-sale and Sunday intoxicating liquor license to Toivo's LLC dba Toivo's and consider approval of license contingent upon receipt of proof of insurance and all required fees. If approved, pro-rate license fee through December 31, 2011.

Sponsors:

Indexes:

Code sections:

Attachments:

Date	Ver.	Action By	Action	Result
------	------	-----------	--------	--------

Title

Conduct a public hearing to receive public input on granting an On-sale and Sunday intoxicating liquor license to Toivo's LLC dba Toivo's and consider approval of license contingent upon receipt of proof of insurance and all required fees. If approved, pro-rate license fee through December 31, 2011.

Body

Background Information:

According to Chapter 6, Article II, Section 6-35 (b) Hearing and Issuance, "(a) Opportunity shall be given to any person to be heard for or against the granting of the license. After the investigation and hearing, the Council shall, in its discretion, grant or refuse the application."

Toivo's LLC is currently in the process of purchasing Clementine's located at 1212 NW 4th Street, Grand Rapids, Minnesota. All required documents will be on file prior to issuance of the license.

Requested City Council Action

Conduct a public hearing to receive public input on granting an On-sale and Sunday intoxicating liquor license to Toivo's LLC dba Toivo's and consider approval of license contingent upon receipt of proof of insurance and all required fees. If approved, pro-rate license fee through December 31, 2011.



CITY OF GRAND RAPIDS

CITY COUNCIL CHAMBERS
420 NORTH POKEGAMA
AVE.

Legislation Details (With Text)

File #: 11-1433 **Version:** 1 **Name:** CP 2014-1 preliminary public hearing
Type: Agenda Item **Status:** Public Hearing
File created: 4/4/2011 **In control:** Engineering
On agenda: 4/11/2011 **Final action:**
Title: Conduct Public Hearing on CP 2014-1, 1st Avenue NE Reconstruction Project.
Sponsors:
Indexes:
Code sections:
Attachments: [4-11-11 CP 2014-1 Attachment Presentation.pdf](#)

Date	Ver.	Action By	Action	Result
------	------	-----------	--------	--------

Title

Conduct Public Hearing on CP 2014-1, 1st Avenue NE Reconstruction Project.

Body

Background Information:

A feasibility report was completed for CP 2014-1, 1st Avenue NE Reconstruction Project and accepted by the City Council on March 28th. The council then established a public hearing for April 11, 2011, at 6:00 p.m. in the council chambers.

The City Engineers presentation is attached.

Staff Recommendation:

City staff is recommending the council conduct the public hearing.

Requested City Council Action

Consider conducting the public hearing on CP 2014-1, 1st Avenue NE Reconstruction Project.



CITY OF
GRAND RAPIDS
IT'S IN MINNESOTA'S NATURE

City Project 2014-1

1st Avenue NE Reconstruction

Project Location

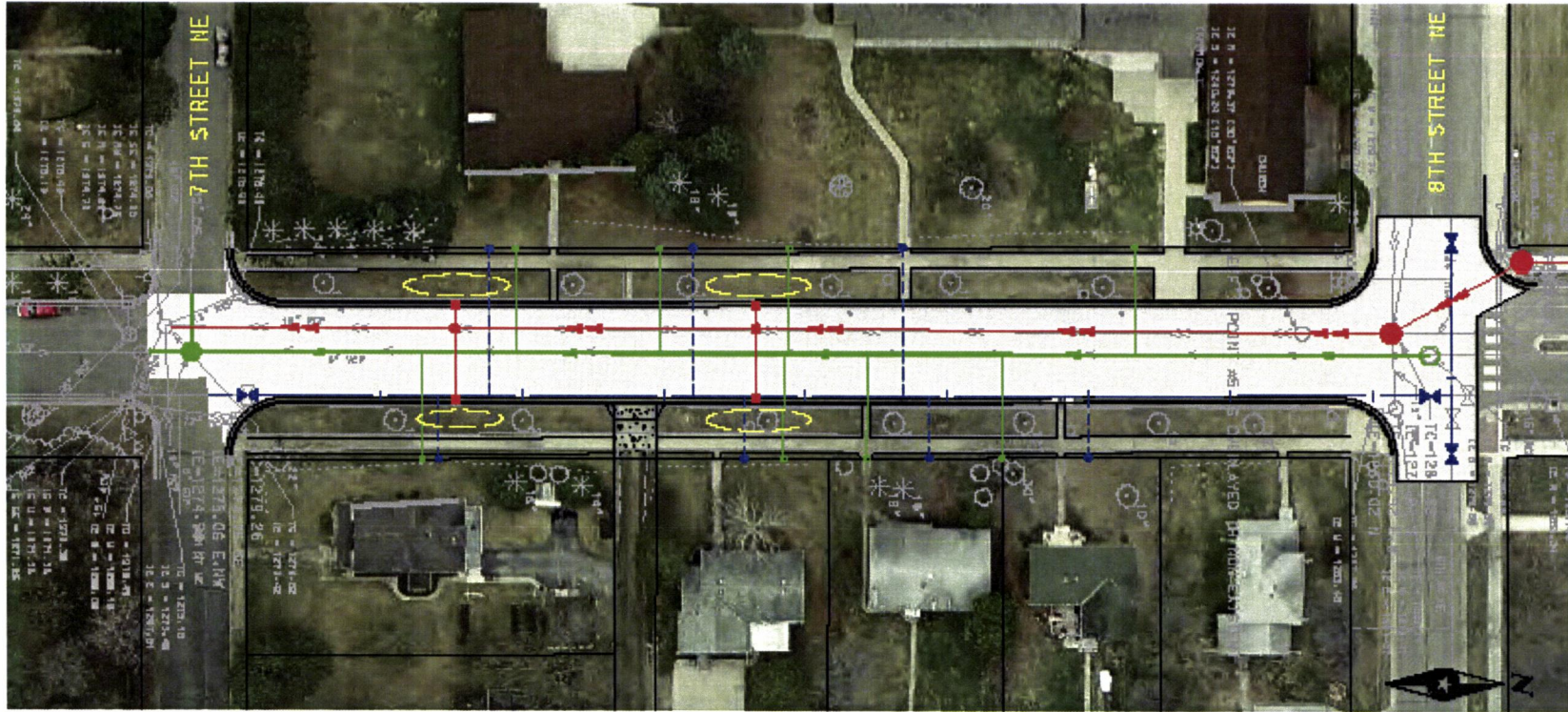

Project Location

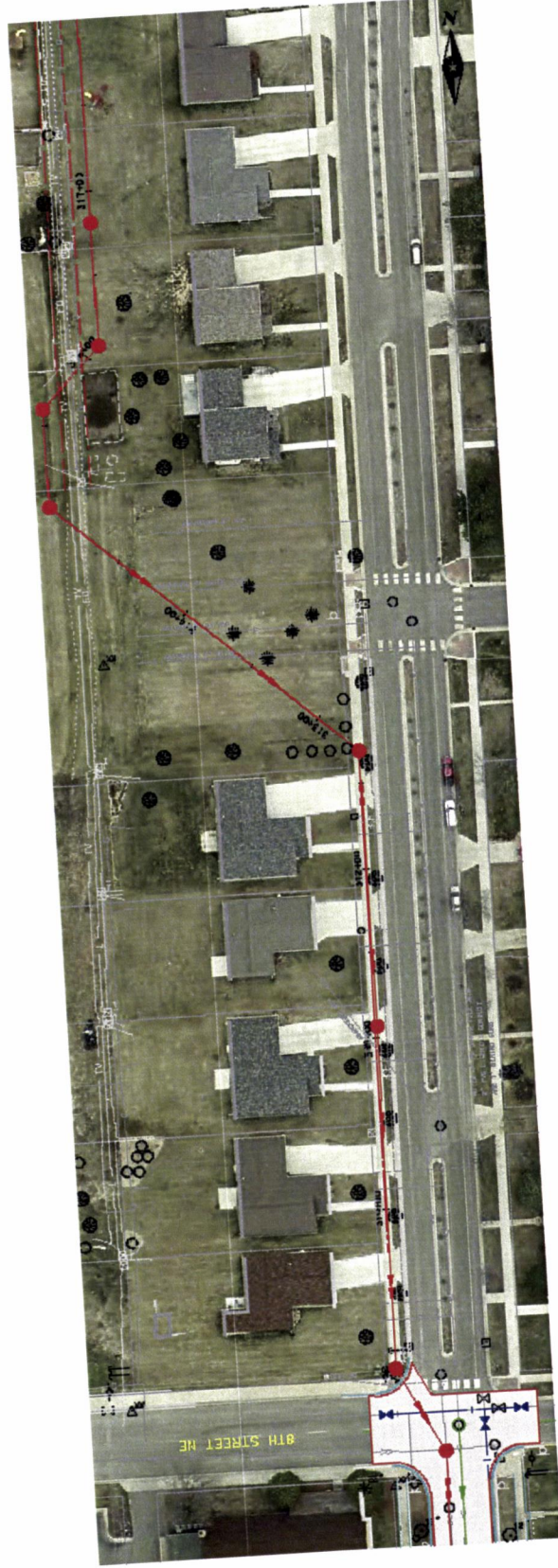

Project Location



The Project Consists of:

- Water Main replacement on 1st Avenue NE from 7th Street to 8th Street
- Sanitary Main replacement on 1st Avenue NE from 7th Street to 8th Street
- Storm Sewer Main, Catch Basin/Lead Replacement, and Rain Gardens
- Street Reconstruction
- Street Lighting

Water Main

- The water main is 6 inch cast iron pipe and records don't identify date or original construction. Estimated in excess of 70 years.
- Will be replaced with 8 inch ductile iron pipe.
- Services will be replaced.

Existing/Proposed Water Main



Sanitary Sewer

- The sanitary is 8 inch vitrified clay pipe and records don't identify date or original construction. Estimated in excess of 70 years.
- Will be reconstructed with 8 inch PVC.
- Services will be placed.

Existing/Proposed Sanitary



Storm Sewer

- Main will be constructed from 7th Street NE to 8th Street NE.
- 12 inch drain tile then constructed under sidewalk from 8th Street NE to 9th Street NE.
- Then NW to utility easement between 1st Avenue and Pokegama, then up utility easement.
- Rain Gardens will be constructed at end of Canal Street due to elevation. These will be similar to 1st Avenue NW constructed last year.

Proposed Storm Sewer in Red. Rain Garden in Yellow

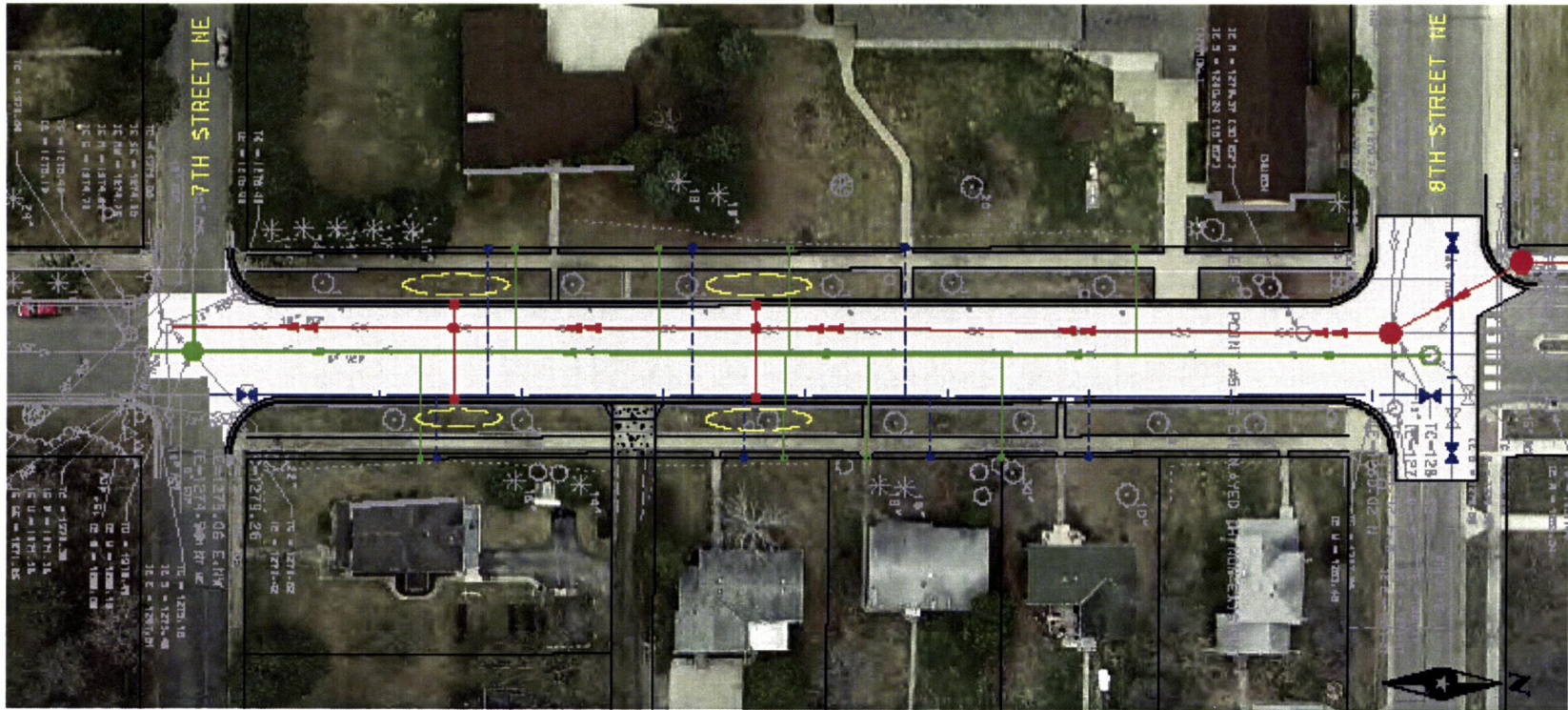

Rain Garden Example



Ground Water Issues



Ground Water Issues



Ground Water Issues



Ground Water Issues



12 inch Drain Tile

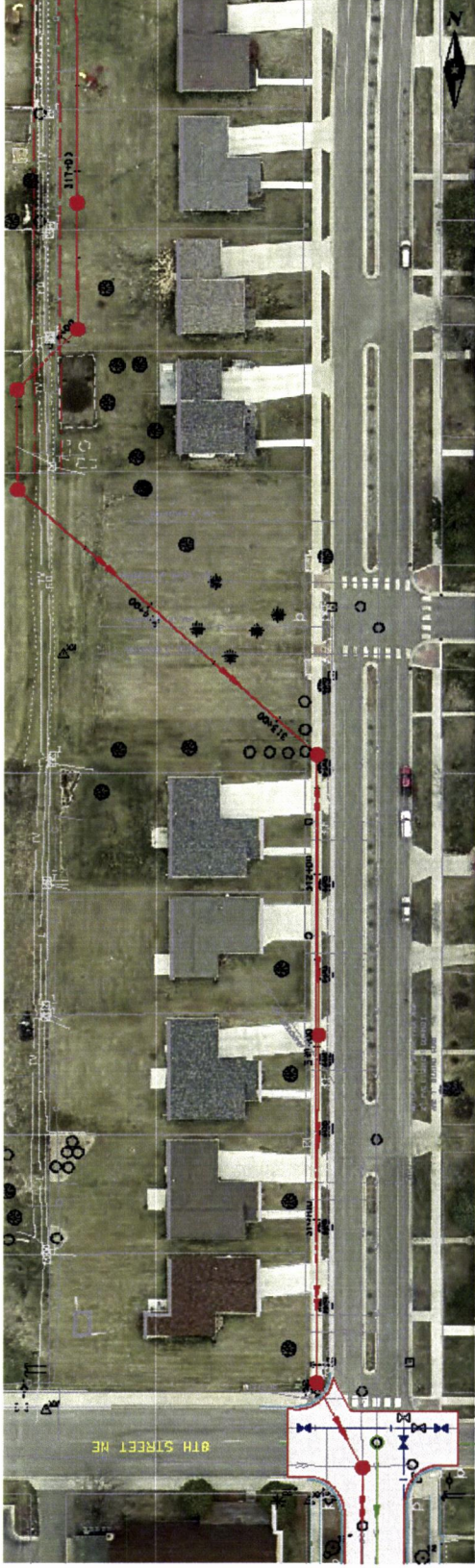

12 inch Drain Tile



Drain Tile Concept

West

East

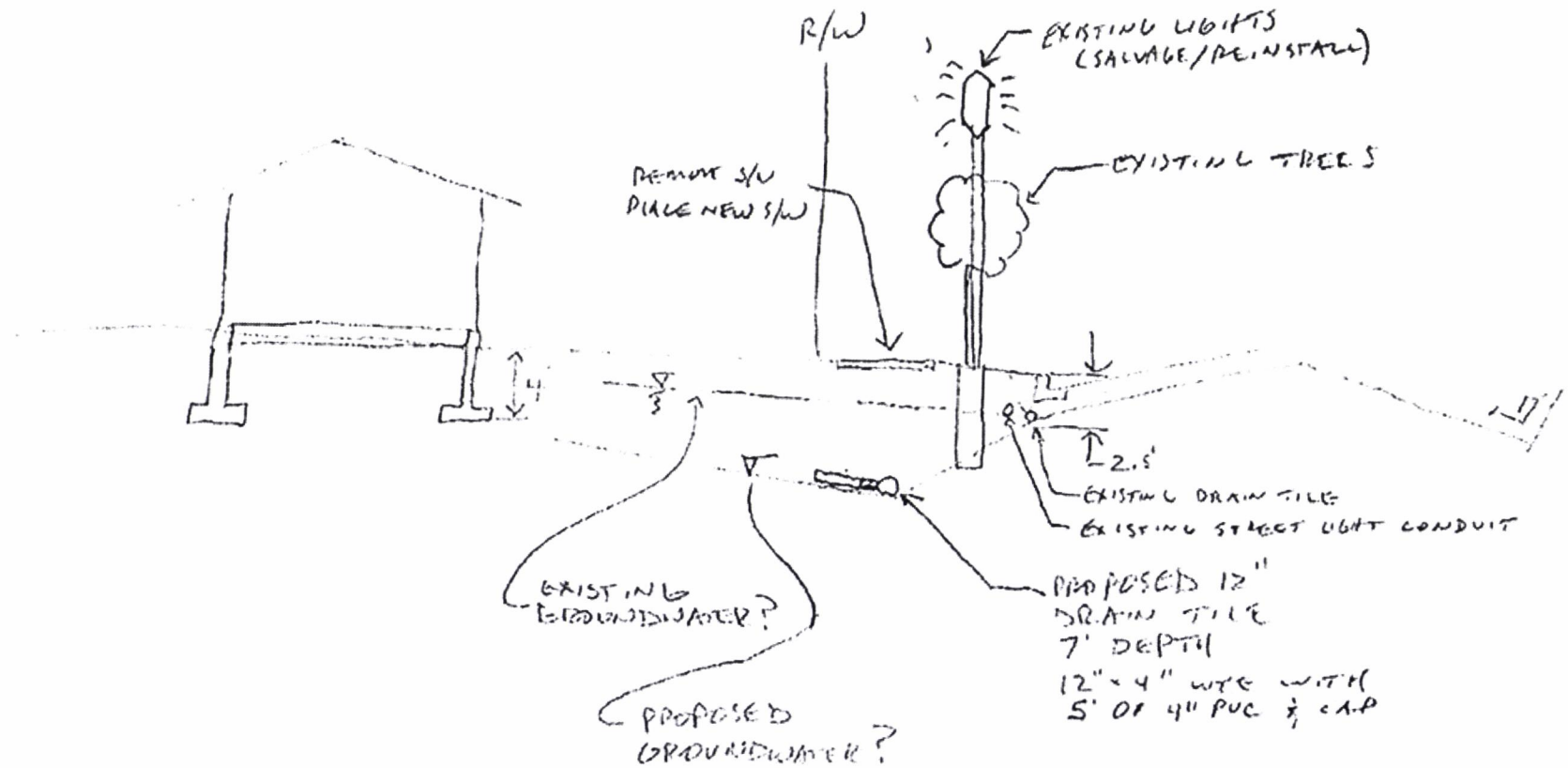

Proposed Street

- Existing Street is 40 feet.
- Proposing to replace with a 40 foot wide street.

Light Enhancements



Street Lights



Public Input

- Conducted neighborhood meetings
 - Monday, March 21, 2011

Project Funding 101

- The City Bonds to Pay for Projects
- In order to Bond the City must assess a minimum of 20%.
- The City can assess less than 20% when the project is reconstructing a street and not changing the street width, or it is a “safety” improvement.
- When assessing property the value of the property must increase, at a minimum, the amount of the assessment.
- The City must also be consistent in the calculation of assessments from class of property to class of property.
- Residential properties must be assessed the same from project to project.
- Non-residential properties must be assessed the same from project to project.

Street Assessments 101

- **Residential** street reconstruction assessments are based on a typical 32' wide street in urban zoned areas and 28' wide in rural areas.
- **30%** of a typical street project cost is assessed to the benefitting properties.

Street Assessments 101 Cont.

- **Non-residential** streets are assessed based on **40%** of the total project cost of the street regardless of street width and pavement thickness.

TYPICAL BENEFIT BOUNDARY

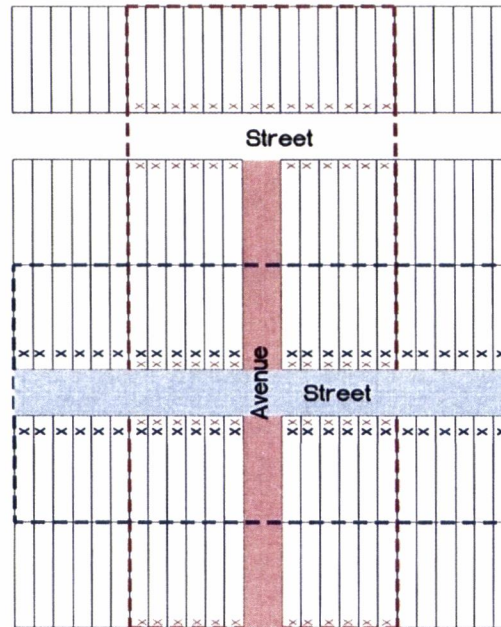

NOTE: THIS FIGURE IS MEANT TO SHOW THE GENERAL WAY IN WHICH IMPROVEMENTS WILL BE ASSESSED, BUT A PROJECT BY PROJECT ANALYSIS SHOULD BE MADE TO DETERMINE THE ACTUAL BENEFITTING AREA.

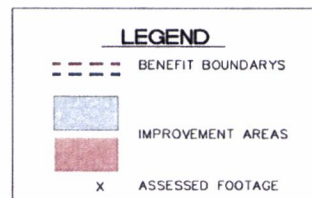

Benefit Area

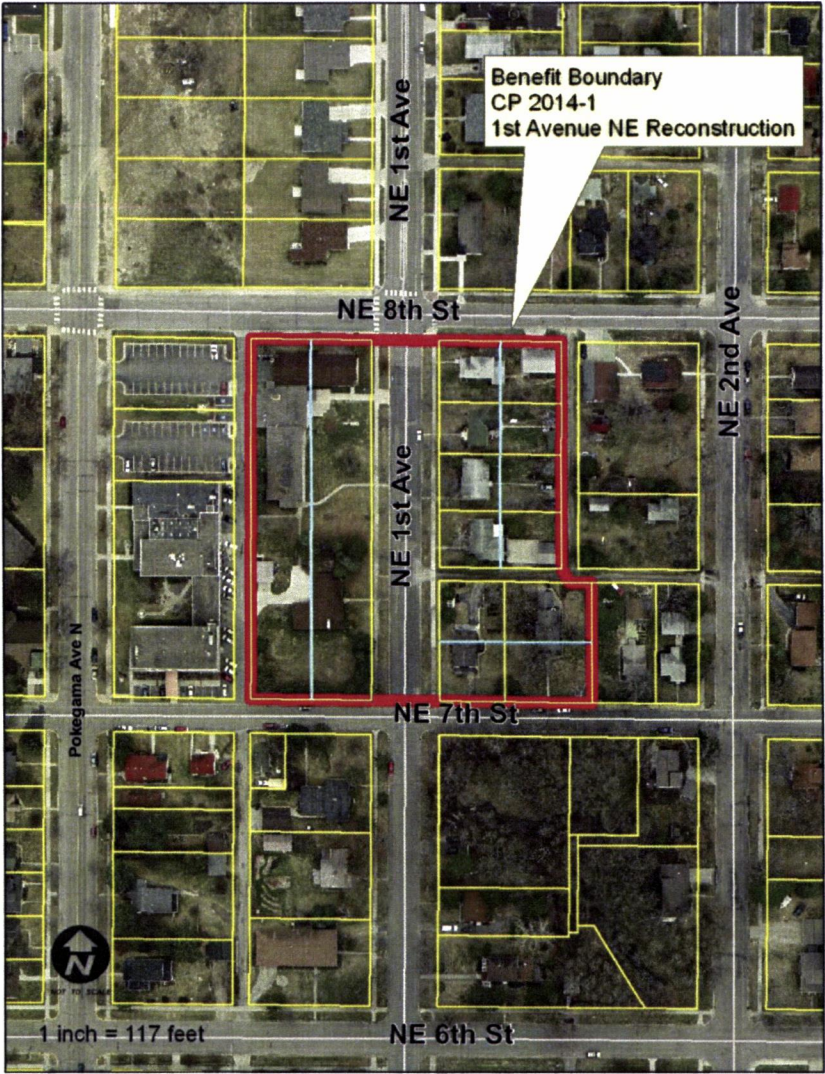

How is assessable footage calculated?

- Assessable footage is typically the narrower dimension of a parcel of property
- The longer parcel footage is utilized when the parcel can be subdivided into multiple lots.

Assessment Calculation

Street Assessment Calculation					
Residential TCI					
Total Length of Project in feet	470.00				
					Total
Standard 32' Wide Street		Quantity	Total	Opinion of	Opinion of
Description	Unit	Per LF	Quantity	Unit Price	Cost
Remove Curb & Gutter	LF	2.00	940.00	\$4.00	\$3,760
Remove Bituminous Pavement	SY	3.22	1513.40	\$3.25	\$4,919
Sawcut Bituminous	LF/LF	0.21	100.11	\$1.60	\$160
Common Excavation	CY/LF	0.65	304.56	\$7.00	\$2,132
Aggregate Base Class 5 (road)	CY/LF	0.65	304.56	\$15.00	\$4,568
Mobilization	LS	0.00	1.00	\$0.00	\$0
Contractor Staking	LS	0.00	1.00	\$0.00	\$0
B618 Concrete Curb & Gutter	LF/LF	2.00	940.00	\$13.00	\$12,220
Type 61 Bituminous Wear (1")	TON/LF	0.19	86.95	\$67.00	\$5,826
Type 31 Bituminous Base (3")	TON/LF	0.53	250.04	\$65.00	\$16,253
4" Concrete Sidewalk w/4" agg base	SF/LF	0.56	261.32	\$3.50	\$915
Traffic Control	LS	0.00	1.00	\$0.00	\$0
Sod, Type Lawn (includes 3" topsoil)	SY/LF	1.33	626.51	\$4.50	\$2,819
				Residential TCI Cost	\$53,571
				Non Construction Cost	\$18,238
				Total Project TCI Cost	\$71,810
				30% Assessed	\$21,543
				Total Assessable Footage	860.00
				Residential Rate per Foot	\$25.0499

Assessments Continued

Water Services

Construction Cost	\$4,440
Non- Construction	\$1,510
Total Water Main	\$5,950
60% GRPU	\$3,570
40% Assessed	\$2,380
Number of Services	4
Assessment Rate	\$595

Sanitary Services

Construction Cost	\$12,940
Non- Construction	\$4,400
Total Water Main	\$17,340
60% GRPU	\$10,404
40% Assessed	\$6,936
Number of Services	8
Assessment Rate	\$867

How do Assessments Get Paid?

- When Project is complete you will receive a final assessment notice.
- You have 30 days to pay all or a portion of your assessment with no interest.
- If you elect to not prepay, assessments are then spread over 15 years and will appear on your property tax statement.
- Fall of 2009 council changed policy to not add 2% on top of bond interest.
- Interest last fall was 3.2%

History of
Street Assessment Rates
for Residential

Project	Year Const.	Ass. Rate/Ft.
1999-20, 7 th Avenue SE	2005	\$18.968
2003-16, 2 nd Avenue SE	2007	\$19.007
2003-20B, 1 st Avenue NW	2008	\$17.035
1 st Ave SE	2009	\$21.17
3 rd Ave Rail	Proposed	\$22.72

Assessment Annual Payments

Terms of 15 years, 4.0% annual interest

- \$2,500 equals \$ 225.85 /Year
- \$5,000 equals \$ 449.71 /Year
- \$7,500 equals \$ 674.56 /Year
- \$10,000 equals \$ 889.41 /Year

Project Cost

Project Cost

CONSTRUCTION COST	\$499,393
7.5% CONTINGENCY	\$37,454
ENGINEERING	\$99,879
LEGAL/PUBLISHING	\$2,500
ADMINISTRATION	\$9,988
COST OF ISSUANCE	\$19,976
LAND	\$0
TOTAL PROJECT COST	\$669,189
% Non-Construction	34.00%

Project Funding

Funding

Assessments	30,859
Storm Water Utility	0
GRPUC Water	72,392
GRPUC Sanitary	41,817
PILOT	0
G.O. Bonding	524,121
Total	669,189

Project Schedule

Feasibility Report to City Council	March 28, 2011
Public hearing	April 11, 2011
Order Plans & specifications	April 11, 2011
Approve Plans and Advertise for Bids	April 25, 2011
Construction	Summer 2011
Final Assessments	Fall 2011

Questions



Legislation Details (With Text)

File #: 11-1434 **Version:** 1 **Name:** CP 2014-1 Order Project
Type: Agenda Item **Status:** Public Hearing
File created: 4/4/2011 **In control:** Engineering
On agenda: 4/11/2011 **Final action:**
Title: A resolution ordering in CP 2014-1, 1st Avenue NE Reconstruction Project and the preparation of plans and specifications.
Sponsors:
Indexes:
Code sections:
Attachments: [4-11-11 Resolution CP 2014-1 Order Improvement and Plans and Specs.pdf](#)

Date	Ver.	Action By	Action	Result
------	------	-----------	--------	--------

Title
A resolution ordering in CP 2014-1, 1st Avenue NE Reconstruction Project and the preparation of plans and specifications.

Body
Background Information:
After conducting the public hearing for CP 2014-1, 1st Avenue NE Reconstruction Project, the City Council can consider ordering the project and the preparation of plans and specifications for the project. A resolution is attached for consideration.

Staff Recommendation:
City staff is recommending the ordering in of CP 2014-1, 1st Avenue NE Reconstruction Project and the preparation of plans and specifications

Requested City Council Action
Consider a resolution ordering in of CP 2014-1, 1st Avenue NE Reconstruction Project and the preparation of plans and specifications.

Council member _____ introduced the following resolution and moved for its adoption:

RESOLUTION NO.11-__

**A RESOLUTION ORDERING IMPROVEMENT OF
AND PLANS AND SPECIFICATIONS FOR THE
1ST AVENUE NE RECONSTRUCTION
PROJECT 2014-1**

WHEREAS, Resolution 11- of the City Council dated the 28th day of March, 2011, accepted the Feasibility Report for the 1st Avenue NE Reconstruction Project; and

WHEREAS, the reconstruction of existing public infrastructure within the right of way and utility/alley easements of 1st Avenue NE, between 7th Street NE and 10th Street NE, including street, sidewalk, street lighting, storm sewer, sanitary sewer, water main, and associated appurtenances, are needed; and

WHEREAS, the construction described in the Feasibility Report for the 1st Avenue NE Reconstruction Project is the most cost effective solution; and

WHEREAS, a resolution of the City Council adopted the 28th day of March, 2011, fixed a date of April 11, 2011, for a Council Hearing on the proposed improvement; and

WHEREAS, ten days' mailed notice and two weeks' published notice of hearing was given and hearing was held thereon on the 11th day of April, 2011, at which all persons desiring to be heard were given an opportunity to be heard.

NOW, THEREFORE, BE IT RESOLVED BY THE CITY COUNCIL OF GRAND RAPIDS, MINNESOTA:

1. Such improvement is hereby ordered as proposed in accordance with the Feasibility Report and referred to therein.
2. The City Engineer is hereby designated as the City's representative for this improvement and he or his designee shall prepare plans and specifications for the making of such improvement.
3. The City reasonably intends to make expenditures for the 1st Avenue NE Reconstruction Project, City Project 2010-3, and reasonably intends to reimburse itself for such expenditures from the proceeds of debt to be issued by the city in the maximum principal amount of \$669,189.
4. The Council shall let the contract for all or part of such improvement, or otherwise as authorized by Minn. Stat. 429.041, subd. 2, no later than April 11, 2013.

Adopted by the Council this 11th day of April, 2011.

Dale Adams, Mayor

ATTEST:

Kim Johnson-Gibeau, City Clerk

Council member _____ seconded the foregoing resolution and the following voted in favor thereof: _____; and the following voted against same: _____; whereby the resolution was declared duly passed and adopted.



Legislation Details (With Text)

File #: 11-1435 **Version:** 1 **Name:** CP 2014-1 SEH SLA
Type: Agenda Item **Status:** Public Hearing
File created: 4/4/2011 **In control:** Engineering
On agenda: 4/11/2011 **Final action:**
Title: A Supplemental Letter Agreement (SLA) with SEH for design and construction services on CP 2014-1, 1st Avenue NE Reconstruction Project.
Sponsors:
Indexes:
Code sections:
Attachments: [4-11-11 Attachment CP 2014-1 SEH SLA .pdf](#)

Date	Ver.	Action By	Action	Result
------	------	-----------	--------	--------

Title

A Supplemental Letter Agreement (SLA) with SEH for design and construction services on CP 2014-1, 1st Avenue NE Reconstruction Project.

Body

Background Information:

After ordering in CP 2014-1, 1st Avenue NE Reconstruction Project and the preparation of plans and specifications, it will be necessary to utilize SEH to provide design and construction engineering services under the Master Engineering Agreement between the City and SEH. The SLA is attached for reference.

Staff Recommendation:

City staff is recommending the attached SLA between the City and SEH to provide design and construction engineering services on CP 2014-1, 1st Avenue NE Reconstruction Project, with an estimated 12.5% percent of construction cost at \$62,424.06.

Requested City Council Action

Consider the attached SLA between the City and SEH to provide design and construction engineering services on CP 2014-1, 1st Avenue NE Reconstruction Project, with an estimated 12.5% percent of construction cost at \$62,424.06.



Supplemental Letter Agreement No. 2014-1

April 4, 2011

Mayor Adams
City of Grand Rapids
420 NE 4th Street
Grand Rapids, MN 55744

RE: 1st Ave NE Reconstruction
City Project 2014-1
SLA for Design and Construction Administration

Dear Mayor Adams,

City Project 2014-1 involves the reconstruction of 1st Ave NE from 7th St to 8th St. Infrastructure being replaced includes: roadway, street lighting, storm sewer, watermain, sanitary sewer, sidewalks and associated appurtenances. Also included in the project is the extension of a storm sewer main on the west side of 1st Ave NE from 8th St north to 9th St, then NW across the new city park, and then north up the platted utility easement to 10th St. The purpose of this storm sewer line is to provide drainage for the high groundwater that is located in this area, thereby protecting the City's infrastructure (sidewalk and curb) in this area from frost heaving.

The City Engineer has requested that we prepare this Supplemental Letter Agreement (SLA) for design and construction administration of all of these improvements for your consideration. Our estimated work scope and fee for this project are listed below and are in accordance with the Master Engineering Services Agreement that is in place between the City of Grand Rapids and Short Elliott Hendrickson, Incorporated (SEH).

SEH Work Scope

The services included in this SLA are for design and construction administration as listed in the Master Agreement in place between the City and SEH.

Project Schedule

Neighborhood Meeting	March 21, 2011
Public Hearing	April 11
Council orders plans and specifications	April 11
Council considers approval of this SLA	April 11
Council approves plans and specifications and authorizes bid	May 9

Advertise in Herald Review (GR – official newspaper)
Advertise on MnDOT's website (trade publication)
Bid opening
Council considers award of contract
Construction
Substantial completion
Final assessments

May 15, 18
May 15
June 7
June 13
July – Sep
September
October, 2011

Fee Schedule

The fee for design tasks will be as listed in the Master Engineering Services Contract (design fee = 6.0% of low construction bid and construction fee = 6.5% of final construction cost). The current construction estimate for this work is \$499,392.50, which equates to an SEH fee of \$62,424.06. The topographic survey (which is part of the design work scope) has previously been completed by SEH and paid for by the City through the Miscellaneous Services contract. Therefore that fee (\$2,560.00) will be deducted from the fee mentioned above. Therefore, total SEH fee is estimated at \$59,864.06.

We look forward to working with you on this project. If this SLA is acceptable, please sign in the space provided and return a copy to us. We will then begin work immediately. Please contact us if you have any questions regarding this supplemental letter agreement.

Sincerely,
Short Elliott Hendrickson Inc.

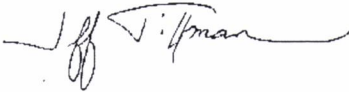

Jeff Tillman, P.E.
Project Manager/Principal



4/4/2011

Robert J. Beaver, P.E.
Office Manager/Principal

Date

City of Grand Rapids Authorization:

Kim Johnson-Gibeau
City Clerk

Date

Dale Adams
Mayor of Grand Rapids

Date

C: SEH contract file



CITY OF GRAND RAPIDS

CITY COUNCIL CHAMBERS
420 NORTH POKEGAMA
AVE.

Legislation Details (With Text)

File #: 11-1436 **Version:** 1 **Name:** CP 2011-4 Public Hearing
Type: Agenda Item **Status:** Public Hearing
File created: 4/4/2011 **In control:** Engineering
On agenda: 4/11/2011 **Final action:**
Title: A public hearing on CP 2011-4, Horseshoe-Isleview Reconditioning Project.
Sponsors:
Indexes:
Code sections:
Attachments: [4-11-11 CP 2011-4 Attachment Presentation.pdf](#)

Date	Ver.	Action By	Action	Result
------	------	-----------	--------	--------

Title

A public hearing on CP 2011-4, Horseshoe-Isleview Reconditioning Project.

Body

Background Information:

The City Council has accepted the feasibility report for CP 2011-4, Horseshoe-Isleview Reconditioning Project and called for a public hearing on the project for April 11, 2011, at 6:00 p.m. in the council chambers. The City Engineers presentation is attached for reference.

Staff Recommendation:

City staff is recommending that the public hearing be conducted.

Requested City Council Action

Consider conducting the public hearing on CP 2011-4, Horseshoe-Isleview Reconditioning Project.



CITY OF
GRAND RAPIDS
IT'S IN MINNESOTA'S NATURE

City Project 2011-4
**Horseshoe-Isleview Partial
Reconditioning**

Project Location



The Project is Part of the
5 YR Capitol
Improvement Plan

Why have a 5 Year Capital Improvement Plan?

- City of Grand Rapids owns and maintains 93 miles of streets.
- Typical life of a street is approximately 30 years.
- Simple math tells us the City has to execute the reconstruction, partial reconstruct or overlay of approximately 3 miles of roadway every year to maintain street integrity.
- Having a 5 Year CIP the City can budget and provide consistent funding to maintain the City street network.

Project Options

- Option 1 – Partial Reconstruction of Isleview, Horseshoe Lake, and Mishawa Roads.
- Option 1A – Adds an 8' pedestrian trail to the Isleview and Horseshoe Lake Road Corridors.
- Option 2 – Is Option 1A with the addition of Reserve Drive, Par Lane, 25th Street SW, and 12 Avenue SW.
- Option 3 – Is the Reconstruction of Isleview and Horseshoe Lake Roads bringing them to MSAS standards with 4' bike lanes. Does not include additional streets in Option 2.

Neighborhood Meetings

- Conducted Neighborhood Meeting on January 17, 2011.
 - Need to accommodate pedestrians (included in Option 1A and 2)
 - Need to reduce speed
 - Need to add Reserve Drive, Par Lane, 25th Street SW, 12th Avenue SW (included in Option 2)
 - Need to restrict tractor trailers

As a result of neighborhood meeting the Recommended Project now consists of:

- The partial reconstruction of streets
- Grade corrections throughout corridors
- Storm culvert replacement and ditch grading
- The construction of an 8 foot wide non-motorized pedestrian trail along Isleview and Horseshoe Lake Roads

Pedestrian Accommodations

Option 1 - None

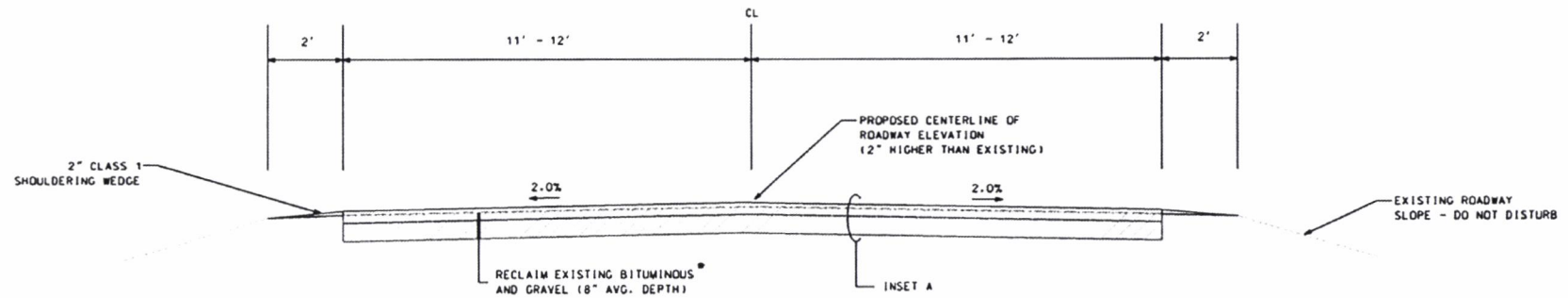

Pedestrian Accommodations

Option 1A

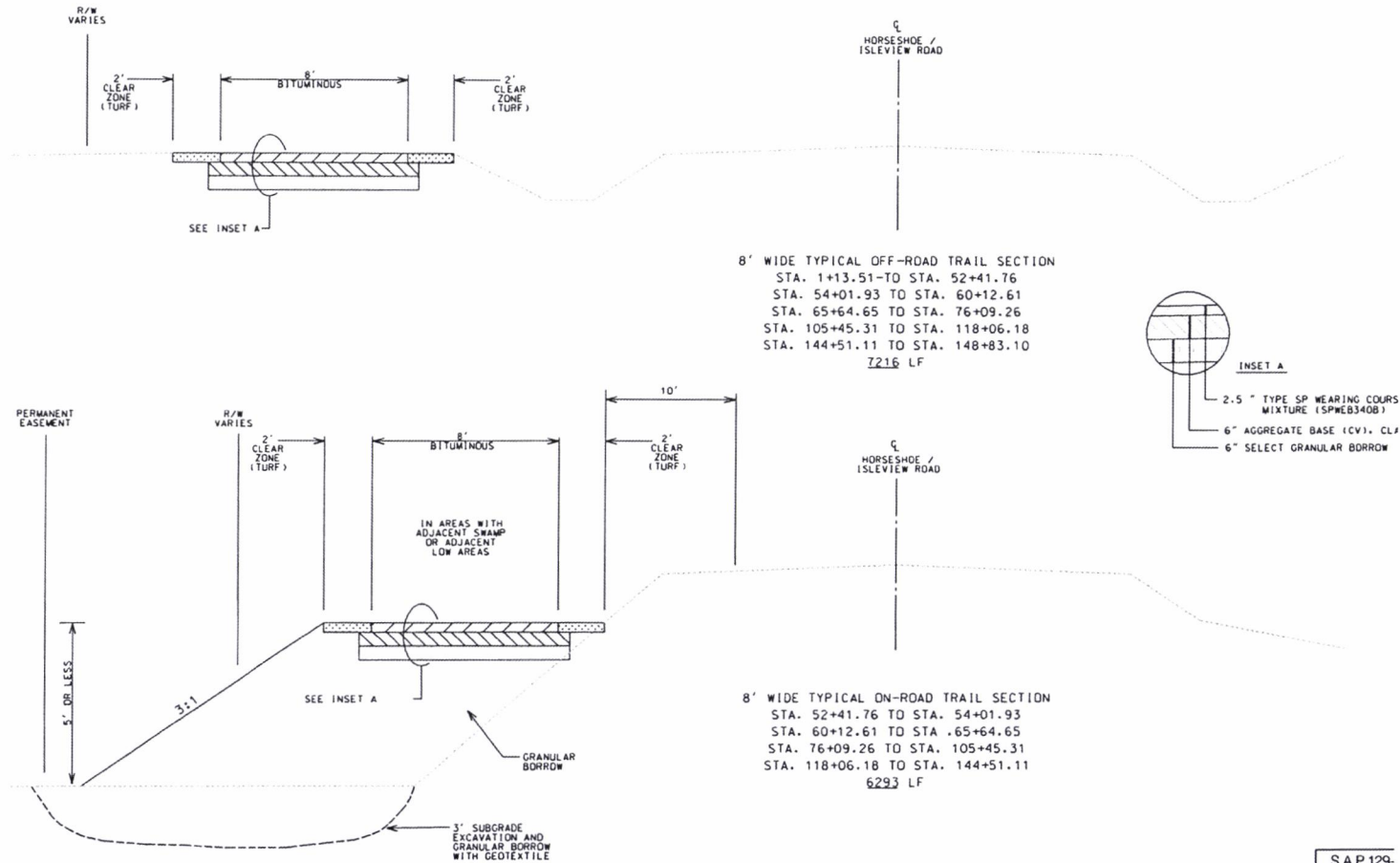

Pedestrian Accommodations Option 3

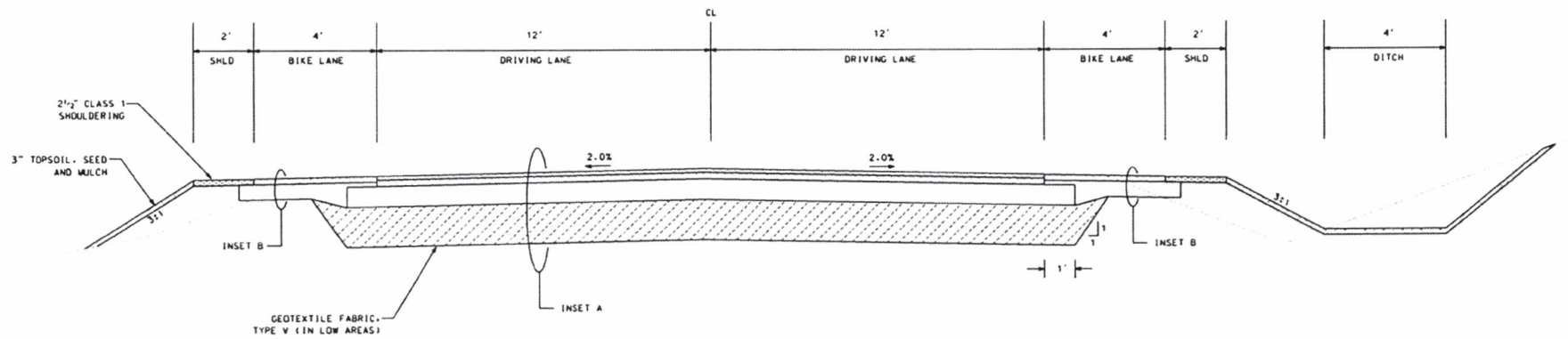

ISLEVIEW AND HORSESHOE LAKE ROAD - RECONSTRUCTION

Research

- Just as important as safety is the need for a healthy community. Researching the Hamline and Grand Rapids Area Library research document data bases yielded twenty two documents with the word “sidewalk” or “trail”. Five of the twenty-two addressed benefits of sidewalks/trails related to health. A summary of those research documents follow:

- (Lindsey, 2004) – Determined that *“Walking appears to be the most common activity on most trails, typically followed by bicycling, running, and skating. Fewer than 5% of users surveyed used trails for commuting”*.
- (Wilson, 2004) – In this study the researchers investigated Socioeconomic Status and Perceptions of Access and Safety for Physical Activity. One of the conclusions stated *“use of the trail increased as a function of trail availability. Moreover, concerns about safety did not appear to be a barrier to trail use, because 86.9% of trail users reported feeling very safe when using the trail”*.
- (Powell, 2003) – The author of this research cites *“Efforts to design new and to retrofit old neighborhoods with sidewalks and streets that make them easily walkable and the development of nearby park space would appeal to residents and be beneficial from a public health perspective”*.

-

- Evans-Cowley, 2006) – This study addressed Sidewalk Planning and Policies in Small Cities. The key points of the article were *“People cite lack of pedestrian connectivity, distance to destination, and lack of time as reasons for not walking. Many people do not walk because sidewalks, if available do not lead to destinations. The pedestrian plan should address critical gaps in the pedestrian network, including those near schools and transit stops. Where feasible, sidewalks should be included as part of every road construction, reconstruction, intersection improvement, and traffic calming project. The benefits of pedestrian-friendly neighborhoods-where people can walk to work, schools, parks, and other destinations-enhance small cities as their sidewalk plans and policies are implemented over time.”*

- (Addy, 2004). The summary of this research document states *“Interventions to increase environmental supports for physical activity should target proximal locations-such as private recreational facilities, parks, playgrounds and sports fields-as well as adequate lighting and the presence of convenient, nearby opportunities for physical activity”*.

Trail Master Plan

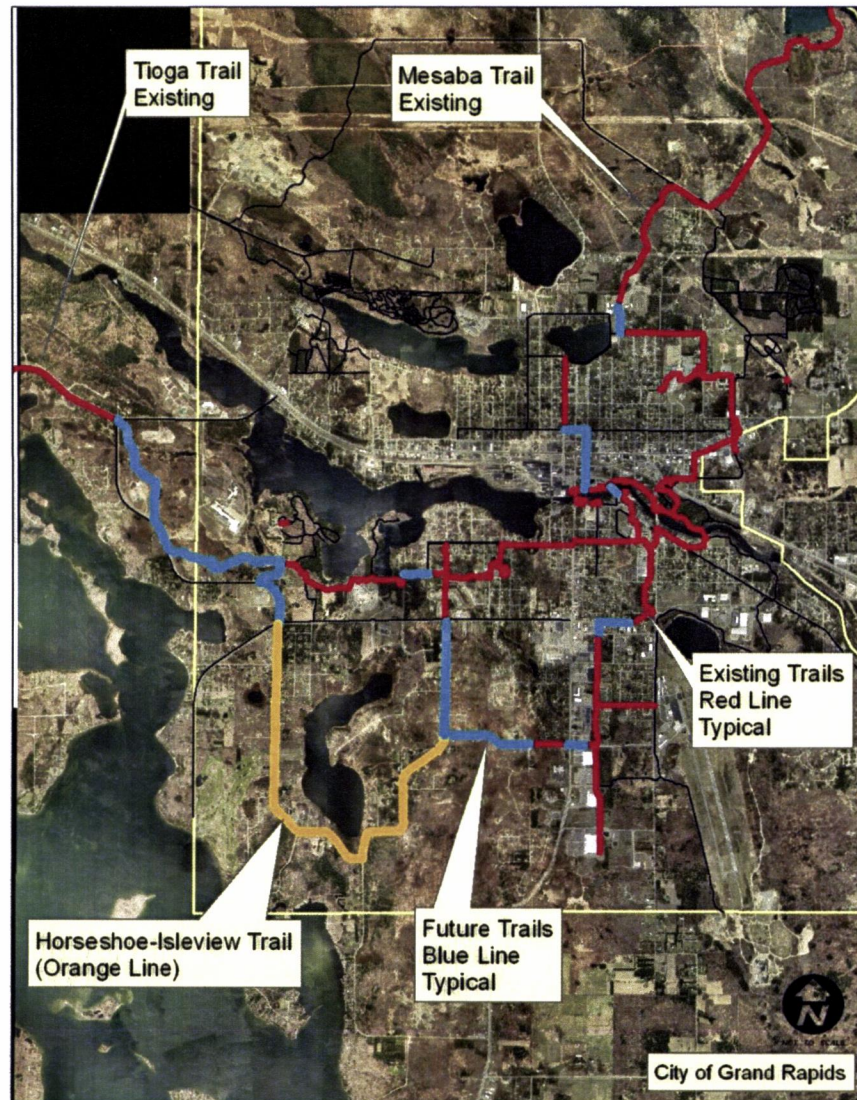

Pros/Cons with Options

- Option 1A & 2 less expensive reconditioning than Option 3 requires reconstruction
- Option 1A & 2 less clearing than Option 3
- Option 1A & 2 less easements than Option 3
- Option 1A & 2 maintains vehicle speed Option 3 will increase speed
- Option 1A & 2 less wetland impact than Option 3

Reduce Speed

- There are two ways to reduce speed
 - Utilize traffic calming such as narrow roads, speed humps
 - Enforce speed limits
- We can't narrow the roads, they are already at 24' in width.
- We will not recommend "speed humps" on a collector street.
- We are recommending Option 2 because it maintains the existing width and minimizes speed. The wider the road the faster the speed.
- 2010 – 9 speeding citations and 4 DWI's

Tractor Trailer Restrictions

- Horseshoe Lake and Isleview Roads are designated as MSAS streets. As a result we can not restrict axle loads.
- We can restrict Mishawaka Road. It could be signed with tractor trailer only “by permitted authorization” or similar wording.

Existing Streets

- Larry Walstad, a resident on Isleview Road indicated it was first paved in 1962
- Former Township employees indicate that Isleview was overlaid in 1989.
- Since 1986 Horseshoe and Mishawaka Roads have had skin patches.
- Par Lane and Reserve Drive were paved in 1980.
- 25th Street was paved in 1982.

Horseshoe east of Islevieiw

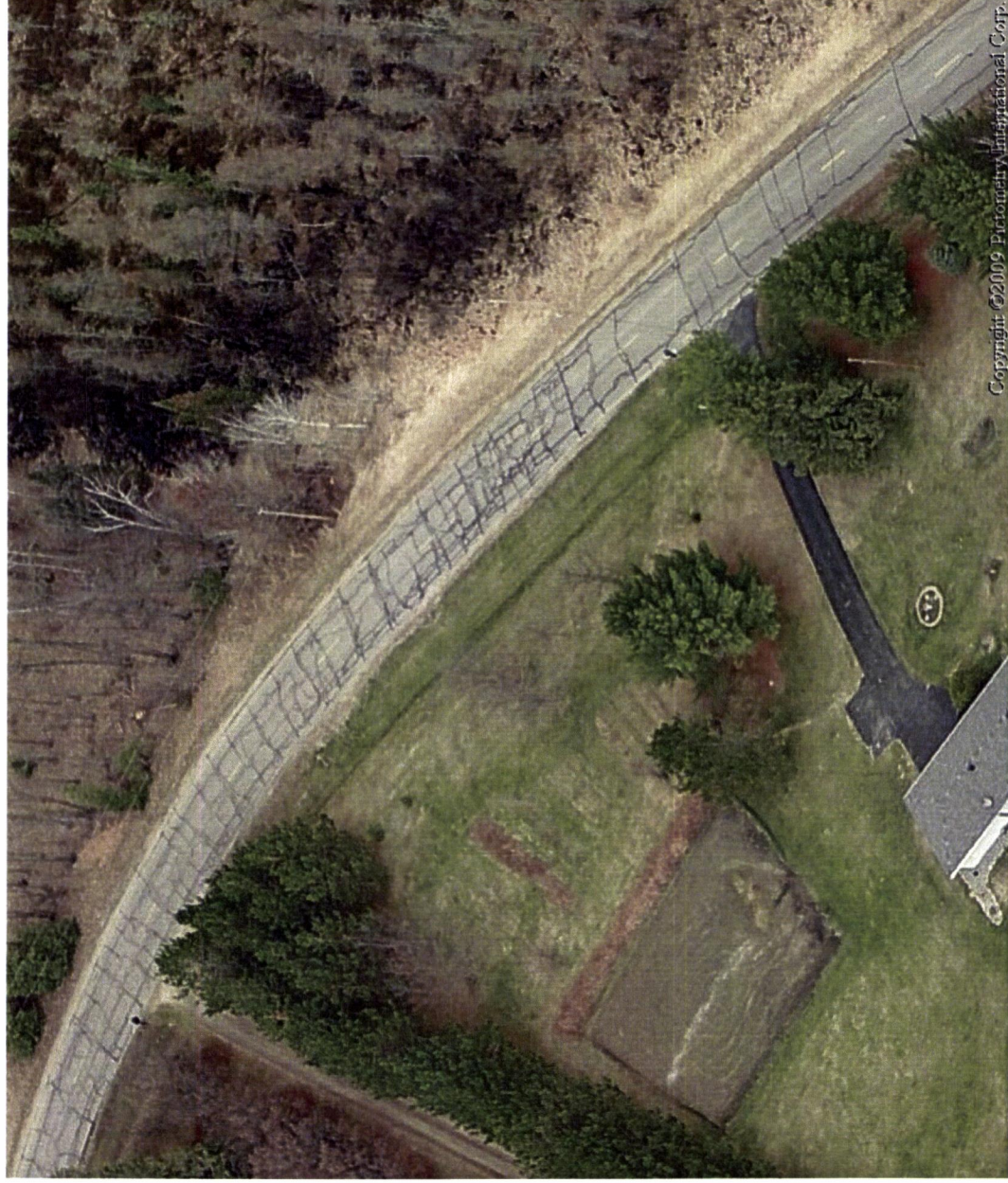

Copyright ©2009 Pictometry International Corp.

Isleview south of Isleview Lane



Horseshoe south of 25th St. SW



Mishawaka north of City Limits



Reserve Drive



Copyright ©2009 Pictometry International Corp.

Par Lane



Copyright ©2009 Pictometry International Corp.

25th Street SW



Copyright ©2009 Pictometry International Corp.

12th Avenue SW



Copyright ©2009 Pictometry International Corp.

Existing Typical Sections

Isleview	22.0'-23.0'	1.5'-3.0'	4:1-6:1	6.5"-8"	4"-6"
Horseshoe Lake	24.0'-25.0'	1.0'-2.5'	4:1-5:1	4"-5"	3"-5"
Mishawaka	23.0'	2.0'-4.0'	4:1	5"-5.5"	4.5"
Par Lane	24.0'	3.0'	3:1	3.25"	4"
Reserve Drive	25.0'	3.0'	3:1	3.25"	5.5"
25 th Street SW	24.5'	3.0'	3:1	2"	4.25"
12th Avenue SW	24.0'	1.5'	3:1	2"	4.25"

Existing bituminous ground and mixed with underlying gravel base.



Base is graded smooth and compacted



Then 4 inches of bituminous is placed



Mail Boxes

- Mail boxes will be removed and salvaged
- Centralized location during construction
 - Determined by US Postal Service
- Replaced with new standard posts and existing mailbox

Storm Water Improvements

- Will consist of:
 - Ditch grading improvements
 - Culvert replacements where needed



Drainage Issues - Islevievw

Isleview Drainage Improvements



Horseshoe Lake Ditching



Drainage Continued



Drainage Continued



Drainage 3



Project Cost

City Participating Project Cost	OPTION			
	OPTION 1	1A	OPTION 2	OPTION 3
CONSTRUCTION COST	1,146,390	1,859,850	2,073,885	2,669,629
5% CONTINGENCY	57,320	92,993	103,694	133,481
ENGINEERING	229,278	371,970	414,777	533,926
LEGAL/PUBLISHING	2,000	4,000	4,000	4,000
ADMINISTRATION	22,928	37,197	41,478	53,393
COST OF ISSUANCE	45,856	74,394	82,955	106,785
LAND	100,000	315,950	315,950	238,908
TOTAL PROJECT COST	1,603,771	2,756,354	3,036,740	3,740,122
% Non-Construction	39.90%	48.20%	46.43%	40.10%
ASSESSMENT RATES/LF	10.11	10.11	11.76	11.19

Project Funding

Funding	OPTION 1	OPTION 1A	OPTION 2	OPTION 3
Assessments	353,044	353,044	451,966	390,752
Storm Water Utility	50,000	50,000	50,000	50,000
MSAS	716,000	1,868,583	1,868,583	2,815,000
G.O. Bonding	484,728	484,728	666,191	484,370
Total	1,603,771	2,756,354	3,036,740	3,740,122

Project Funding 101

- The City Bonds to Pay for Projects
- In order to Bond the City must assess a minimum of 20%.
- The City can assess less than 20% when the project is reconstructing a street and not changing the street width, or it is a “safety” improvement.
- When assessing property the value of the property must increase, at a minimum, the amount of the assessment.
- The City must also be consistent in the calculation of assessments from class of property to class of property.
- Residential properties must be assessed the same from project to project.
- Non-residential properties must be assessed the same from project to project.

Street Assessments 101

- **Residential** street reconstruction assessments are based on a typical 32' wide street in urban zoned areas and 28' wide in rural areas.
- **30%** of a typical street project cost is assessed to the benefitting properties.

TYPICAL BENEFIT BOUNDARY

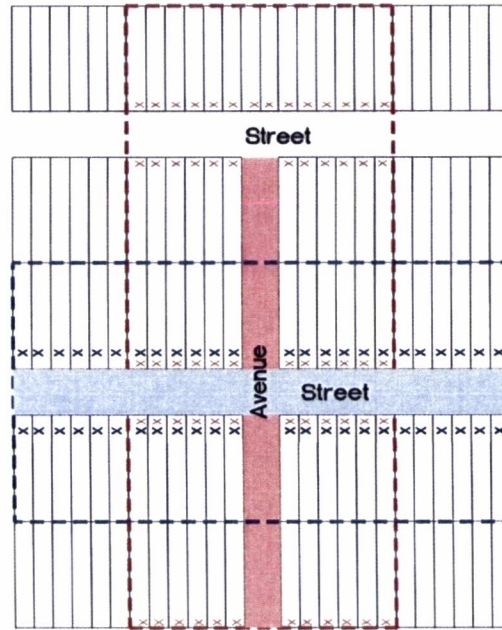

NOTE: THIS FIGURE IS MEANT TO SHOW THE GENERAL WAY IN WHICH IMPROVEMENTS WILL BE ASSESSED, BUT A PROJECT BY PROJECT ANALYSIS SHOULD BE MADE TO DETERMINE THE ACTUAL BENEFITTING AREA.

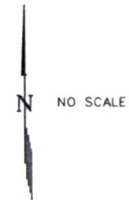
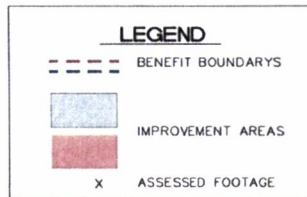

How is assessable footage calculated?

- Assessable footage is typically the narrower dimension of a parcel of property
- The longer parcel footage is utilized when the parcel can be subdivided into multiple lots.
 - 200' road frontage
 - 1.5 acres

Benefit Area



Assessment Calc. Option 1

City Project 2011-4

Horseshoe/Isleview Partial Reconditioning
Residential Assessments
Based on Opinion of Cost
Option 1

Rural Street Partial Reconstruction Assessment Calculation					
Rural Residential TCI					
Total Length of Project in feet 16579					
					Total
Standard 28' Wide Rural Street		Quantity	Total	Opinion of	Opinion of
Description	Unit	Per LF	Quantity	Unit Price	Cost
Remove Curb & Gutter	LF	0	0	\$0.00	\$0.00
Reclaim Bituminous Pavement	SY	3.11	51561	\$1.40	\$72,184.75
Sawcut Bituminous	LF/LF	0.213	3531.3	\$3.50	\$12,359.61
Common Excavation	CY/LF	0	0	\$0.00	\$0.00
Aggregate Base Class 5 (road)	CY/LF	0.277	4592.4	\$14.00	\$64,293.17
Mobilization	LS	0	1	\$15,000.00	\$15,000.00
Contractor Staking	LS	0	1	\$15,000.00	\$15,000.00
B618 Concrete Curb & Gutter	LF/LF	0	0	\$0.00	\$0.00
Type 61 Bituminous Wear (1.5")	TON/LF	0.28	4642.1	\$62.00	\$287,810.57
Type 31 Bituminous Base (2")	TON/LF	0.35	5802.6	\$62.00	\$359,763.22
4" Concrete Sidewalk w/4" agg base	SF/LF	0	0	\$0.00	\$0.00
Traffic Control	LS	0	1	\$15,000.00	\$15,000.00
Shoulder Establishment	CY/LF	0.07	1160.5	\$55.00	\$63,828.96
				Residential TCI Cost	\$905,240.27
				Non Construction Cost	\$271,572.08
				Total Project TCI Cost	\$1,176,812.35
				30% Assessed	\$353,043.70
				Total Assessable Footage	34905.608
				Residential Rate per Foot	\$10.1142

Assessment Calc. Option 2

City Project 2011-4
 Horseshoe/Isleview Partial Reconditioning
 Residential Assessments
 Based on Opinion of Cost
 Option 2

Rural Street Partial Reconstruction Assessment Calculation					
Rural Residential TCI					
Total Length of Project in feet					
					Total
Standard 28' Wide Rural Street	Unit	Quantity Per LF	Total Quantity	Opinion of Unit Price	Opinion of Cost
Remove Curb & Gutter	LF	0	0	\$0.00	\$0.00
Reclaim Bituminous Pavement	SY	3.11	66763.459	\$1.40	\$93,468.84
Sawcut Bituminous	LF/LF	0.213	4572.5456	\$3.50	\$16,003.91
Common Excavation	CY/LF	0	0	\$0.00	\$0.00
Aggregate Base Class 5 (road)	CY/LF	0.277	5946.456	\$14.00	\$83,250.38
Mobilization	LS	0	1	\$15,000.00	\$15,000.00
Contractor Staking	LS	0	1	\$15,000.00	\$15,000.00
B618 Concrete Curb & Gutter	LF/LF	0	0	\$0.00	\$0.00
Type 61 Bituminous Wear (1.5")	TON/LF	0.28	6010.858	\$62.00	\$372,673.20
Type 31 Bituminous Base (2")	TON/LF	0.35	7513.5725	\$62.00	\$465,841.50
4" Concrete Sidewalk w/4" agg base	SF/LF	0	0	\$0.00	\$0.00
Traffic Control	LS	0	1	\$15,000.00	\$15,000.00
Shoulder Establishment	CY/LF	0.07	1502.7145	\$55.00	\$82,649.30
				Residential TCI Cost	\$1,158,887.12
				Non Construction Cost	\$347,666.14
				Total Project TCI Cost	\$1,506,553.26
				30% Assessed	\$451,965.98
				Total Assessable Footage	38421.868
				Residential Rate per Foot	\$11.7632

How do Assessments Get Paid?

- When Project is complete you will receive a final assessment notice.
- You have 30 days to pay all or a portion of your assessment with no interest.
- If you elect to not prepay, assessments are then spread over 15 years and will appear on your property tax statement.
- Interest has typically been 3.5%

Assessment Annual Payments

Terms of 15 years, 3.5% annual interest

- \$2,500 equals \$ 217.06 /Year
- \$5,000 equals \$ 434.13 /Year
- \$7,500 equals \$ 651.19 /Year
- \$10,000 equals \$ 868.25 /Year

Project Schedule

Feasibility Report to council	March 28, 2011
Neighborhood Meeting	January 17 & March 16, 2011
Public Hearing	April 11, 2011
Order Plans & Specifications	April 11, 2011
Approve Plans and Advertise for Bids	July 11, 2011
Open Bids	August 3, 2011
Award Contract	August 8, 2011
Construction	August, 2011 – June 2012
Final Assessments	Fall, 2012

Questions



Legislation Details (With Text)

File #: 11-1437 **Version:** 1 **Name:** CP 2011-4 Order Project
Type: Agenda Item **Status:** Public Hearing
File created: 4/4/2011 **In control:** Engineering
On agenda: 4/11/2011 **Final action:**
Title: A resolution ordering in CP 2011-4, Horseshoe-Isleview Reconditioning Project, and the preparation of plans and specifications.
Sponsors:
Indexes:
Code sections:
Attachments: [4-11-11 Resolution CP 2011-4 Order Improvement and Plans and Specs.pdf](#)

Date	Ver.	Action By	Action	Result
------	------	-----------	--------	--------

Title

A resolution ordering in CP 2011-4, Horseshoe-Isleview Reconditioning Project, and the preparation of plans and specifications.

Body

Background Information:

After the public hearing on CP 2011-4, Horseshoe-Isleview Reconditioning Project, the City Council can consider a resolution ordering in CP 2011-4, Horseshoe-Isleview Reconditioning Project, and the preparation of plans and specifications. A resolution is attached.

Staff Recommendation:

City staff is recommending the resolution ordering in CP 2011-4, Horseshoe-Isleview Reconditioning Project, and the preparation of plans and specifications.

Requested City Council Action

Consider a resolution ordering in CP 2011-4, Horseshoe-Isleview Reconditioning Project, and the preparation of plans and specifications.

Council member _____ introduced the following resolution and moved for its adoption:

RESOLUTION NO.11-__

**A RESOLUTION ORDERING IMPROVEMENT OF
AND PLANS AND SPECIFICATIONS FOR THE
HORSESHOE-ISLEVIEW PARTIAL RECONDITIONING
PROJECT 2011-4**

WHEREAS, Resolution 11- of the City Council dated the 28th day of March, 2011, accepted the Feasibility Report for the Horseshoe-Isleview Partial Reconditioning Project; and

WHEREAS, the reconditioning of existing streets including Isleview Road, from CSAH 23 to Horseshoe Lake Road, Horseshoe Lake Road from Isleview Road to Oakdale Drive, Mishawaka Road from south City Limits to Horseshoe Lake Road, Par Lane, Reserve Drive, 25th Street SW from Horseshoe Lake Road to a point approximately 1,320 feet east, and 12th Avenue SW from 25th Street SW north approximately 480 feet, by partially reconstructing streets, reconstructing storm sewer, and associated appurtenances along with constructing a bituminous pedestrian non-motorized path along Isleview Road and Horseshoe Lake Road in the limits described above, are needed; and

WHEREAS, the construction described in the Feasibility Report for the Horseshoe-Isleview Partial Reconditioning Project is the most cost effective solution; and

WHEREAS, a resolution of the City Council adopted the 28th day of March, 2011, fixed a date of April 11, 2011, for a Council Hearing on the proposed improvement; and

WHEREAS, ten days' mailed notice and two weeks' published notice of hearing was given and hearing was held thereon on the 11th day of April, 2011, at which all persons desiring to be heard were given an opportunity to be heard.

NOW, THEREFORE, BE IT RESOLVED BY THE CITY COUNCIL OF GRAND RAPIDS, MINNESOTA:

1. Such improvement is hereby ordered as proposed as Option 2 in accordance with the Feasibility Report and referred to therein.
2. The City Engineer is hereby designated as the City's representative for this improvement and he or his designee shall prepare plans and specifications for the making of such improvement.
3. The City reasonably intends to make expenditures for the Horseshoe-Isleview Partial Reconditioning Project, City Project 2011-4, and reasonably intends to reimburse itself for such expenditures from the proceeds of debt to be issued by the city in the maximum principal amount of \$3,036,740.
4. The Council shall let the contract for all or part of such improvement, or otherwise as authorized by Minn. Stat. 429.041, subd. 2, no later than April 11, 2013.

Adopted by the Council this 11th day of April, 2011.

Dale Adams, Mayor

ATTEST:

Kim Johnson-Gibeau, City Clerk

Council member _____ seconded the foregoing resolution and the following voted in favor thereof: _____ ; and the following voted against same: _____ ; whereby the resolution was declared duly passed and adopted.

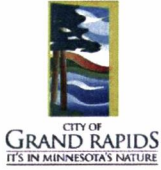

Legislation Details (With Text)

File #: 11-1449 **Version:** 1 **Name:** VERIFIED CLAIMS
Type: Agenda Item **Status:** Verified Claims
File created: 4/6/2011 **In control:** Finance
On agenda: 4/11/2011 **Final action:**
Title: Consider approving the verified claims for the period March 22, 2011 to April 4, 2011 in the total amount of \$276,088.85.
Sponsors:
Indexes:
Code sections:
Attachments: [4/11/2011 BILL LIST](#)

Date	Ver.	Action By	Action	Result
------	------	-----------	--------	--------

Title

Consider approving the verified claims for the period March 22, 2011 to April 4, 2011 in the total amount of \$276,088.85.

Requested City Council Action

Consider approving the verified claims for the period March 22, 2011 to April 4, 2011 in the total amount of \$276,088.85.

COUNCIL BILL LIST - APRIL 11, 2011

DATE: 04/06/11
 TIME: 15:45:15

CITY OF GRAND RAPIDS
 DEPARTMENT SUMMARY REPORT

PAGE: 1

INVOICES DUE ON/BEFORE 04/11/11

VENDOR #	NAME	AMOUNT DUE
GENERAL FUND		
CITY WIDE		
1415377	NORTHERN BUSINESS PRODUCTS INC	31.80
1506265	NORTHERN OFFICE OUTFITTER INC	256.46
TOTAL CITY WIDE		288.26
ADMINISTRATION		
0301358	CAIR MINNESOTA	30.00
0718060	GRAND RAPIDS NEWSPAPERS INC	87.80
1506265	NORTHERN OFFICE OUTFITTER INC	323.78
1915248	SOFTWARE HOUSE INTERNATIONAL	172.07
1920240	STERLE LAW OFFICE	2,730.00
TOTAL ADMINISTRATION		3,343.65
BUILDING MAINTENANCE-CITY HALL		
0103325	ACHESON TIRE COMPANY INC	20.00
0113233	AMERIPRIDE LINEN & APPAREL	66.00
0315455	COLE HARDWARE INC	57.66
0522103	EVANS ELECTRIC INC	169.00
0920060	ITASCA COUNTY TREASURER	1,311.27
1909510	SIM SUPPLY INC	189.19
2008850	THYSSENKRUPP ELEVATOR INC	1,928.75
TOTAL BUILDING MAINTENANCE-CITY HALL		3,741.87
COMMUNITY DEVELOPMENT		
0315455	COLE HARDWARE INC	14.95
1415377	NORTHERN BUSINESS PRODUCTS INC	73.42
1915248	SOFTWARE HOUSE INTERNATIONAL	1,032.41
1920240	STERLE LAW OFFICE	975.00
1920555	STOKES PRINTING COMPANY	255.43
TOTAL COMMUNITY DEVELOPMENT		2,351.21
COUNCIL/COMMISSION/BOARDS		
1920240	STERLE LAW OFFICE	715.00
TOTAL COUNCIL/COMMISSION/BOARDS		715.00
ENGINEERING		
1915248	SOFTWARE HOUSE INTERNATIONAL	860.34

COUNCIL BILL LIST - APRIL 11, 2011

DATE: 04/06/11
 TIME: 15:45:15

CITY OF GRAND RAPIDS
 DEPARTMENT SUMMARY REPORT

PAGE: 2

INVOICES DUE ON/BEFORE 04/11/11

VENDOR #	NAME	AMOUNT DUE
GENERAL FUND		
ENGINEERING		
1920240	STERLE LAW OFFICE	1,073.50
	TOTAL ENGINEERING	1,933.84
FINANCE		
1105530	KENNEDY & GRAVEN	74.10
1415377	NORTHERN BUSINESS PRODUCTS INC	12.61
1801613	RAPIDS PRINTING	354.77
1915248	SOFTWARE HOUSE INTERNATIONAL	860.34
1920650	STRATEGIC INSIGHTS, INC	1,442.81
	TOTAL FINANCE	2,744.63
FIRE		
0401804	DAVIS OIL	198.71
0920045	ITASCA COUNTY FIRE CHIEFS	100.00
1415030	NORD AUTO PARTS	31.90
1415580	NORTHSIDE LUMBER COMPANY	69.20
1903333	ISD #318 PRINT SHOP	32.25
1915248	SOFTWARE HOUSE INTERNATIONAL	172.07
	TOTAL FIRE	604.13
PUBLIC WORKS		
0103325	ACHESON TIRE COMPANY INC	282.19
0121721	AUTO VALUE - GRAND RAPIDS	138.71
0221650	BURGGRAF'S ACE HARDWARE INC	76.91
0301685	CARQUEST AUTO PARTS	509.69
0301727	CATCO PARTS SERVICE INC	167.55
0315455	COLE HARDWARE INC	163.01
0401804	DAVIS OIL	20.78
0501650	EFA PARK AND RECREATION	549.33
0518366	ERICKSON'S ITASCA LUMBER INC	56.43
0801836	HAWKINSON SAND & GRAVEL	427.79
1415030	NORD AUTO PARTS	555.82
1415377	NORTHERN BUSINESS PRODUCTS INC	320.63
1421155	NUCH'S IN THE CORNER	225.81
1615650	PORTABLE JOHN	241.72
1621125	PUBLIC UTILITIES COMMISSION	726.05
1801590	RAPIDS FORD LINCOLN	383.62
1915248	SOFTWARE HOUSE INTERNATIONAL	344.14
2015825	TOWMASTER INC	35.88
2300765	W.W. WALLWORK INC	306.54

COUNCIL BILL LIST - APRIL 11, 2011

DATE: 04/06/11
 TIME: 15:45:15

CITY OF GRAND RAPIDS
 DEPARTMENT SUMMARY REPORT

PAGE: 3

INVOICES DUE ON/BEFORE 04/11/11

VENDOR #	NAME	AMOUNT DUE
GENERAL FUND		
PUBLIC WORKS		
TOTAL PUBLIC WORKS		5,532.60
FLEET MAINTENANCE		
0103325	ACHESON TIRE COMPANY INC	1,816.88
0121721	AUTO VALUE - GRAND RAPIDS	10.01
0301685	CARQUEST AUTO PARTS	126.75
1301015	MACQUEEN EQUIPMENT INC	1,582.84
1415030	NORD AUTO PARTS	273.64
1621125	PUBLIC UTILITIES COMMISSION	14.79
TOTAL FLEET MAINTENANCE		3,824.91
POLICE		
0121725	AUTOMOTIVE ELECTRIC SERVICE	38.48
0301685	CARQUEST AUTO PARTS	227.19
0409501	DIMICH LAW OFFICE	6,250.00
0701480	GALLS, AN ARAMARK COMPANY	95.04
1309167	MN BUREAU OF CRIMINAL	390.00
1415362	NORTHEAST LAW ENFORCEMENT	75.00
1415377	NORTHERN BUSINESS PRODUCTS INC	389.53
1801580	RAPIDS BODY SHOP	833.60
1920233	STREICHER'S INC	1,068.69
1920240	STERLE LAW OFFICE	130.00
TOTAL POLICE		9,497.53
RECREATION		
1415377	NORTHERN BUSINESS PRODUCTS INC	122.34
1605665	PERSONNEL DYNAMICS, LLC	873.60
1915248	SOFTWARE HOUSE INTERNATIONAL	1,032.41
TOTAL RECREATION		2,028.35
CIVIC CENTER		
GENERAL ADMINISTRATION		
0113233	AMERIPRIDE LINEN & APPAREL	106.30
0605670	FERRELLGAS	51.30
0609457	FILTHY CLEAN	200.80
0618353	KEVIN FRIESEN	1,280.00
1300200	MDF INDUSTRIES INC	101.50
1301168	MARKETPLACE FOODS	29.41

COUNCIL BILL LIST - APRIL 11, 2011

DATE: 04/06/11
 TIME: 15:45:15

CITY OF GRAND RAPIDS
 DEPARTMENT SUMMARY REPORT

PAGE: 4

INVOICES DUE ON/BEFORE 04/11/11

VENDOR #	NAME	AMOUNT DUE
CIVIC CENTER		
GENERAL ADMINISTRATION		
1415655	NORVEND INC	99.00
1605611	PEPSI-COLA	942.81
1801610	RAPIDS PLUMBING & HEATING INC	453.00
1901535	SANDSTROM COMPANY INC	801.80
1909510	SIM SUPPLY INC	219.88
1915248	SOFTWARE HOUSE INTERNATIONAL	688.28
1920555	STOKES PRINTING COMPANY	30.66
TOTAL GENERAL ADMINISTRATION		5,004.74
RECREATION PROGRAMS		
1309495	MINUTEMAN PRESS	543.29
1415580	NORTHSIDE LUMBER COMPANY	13.09
TOTAL		556.38
POLICE DESIGNATED FORFEITURES		
0315585	COP STOP	619.88
TOTAL		619.88
CEMETERY		
0221650	BURGGRAF'S ACE HARDWARE INC	23.47
1415590	NORTHWEST GAS	1,673.83
1801595	RAPIDS HYDRAULIC & MACHINE INC	224.62
1920555	STOKES PRINTING COMPANY	89.64
TOTAL		2,011.56
DOMESTIC ANIMAL CONTROL FAC		
0113233	AMERIPRIDE LINEN & APPAREL	14.89
1415048	NORTH COUNTRY VET CLINIC	173.60
1909510	SIM SUPPLY INC	33.00
TOTAL		221.49
CAPITAL EQPT REPLACEMENT FUND		

COUNCIL BILL LIST - APRIL 11, 2011

DATE: 04/06/11
 TIME: 15:45:15

CITY OF GRAND RAPIDS
 DEPARTMENT SUMMARY REPORT

PAGE: 5

INVOICES DUE ON/BEFORE 04/11/11

VENDOR #	NAME	AMOUNT DUE
CAPITAL EQPT REPLACEMENT FUND		
CAPITAL OUTLAY-POLICE		
0205725	BETZ EXTINGUISHER COMPANY	39.00
0315585	COP STOP	1,987.79
0701480	GALLS, AN ARAMARK COMPANY	1,234.45
TOTAL CAPITAL OUTLAY-POLICE		3,261.24
19TH AVE-DO NOT USE SEE 473-19		
2010-03 DO NOT USE!!!!		
1920240	STERLE LAW OFFICE	1,137.50
TOTAL 2010-03 DO NOT USE!!!!		1,137.50
STORM WATER UTILITY		
0401804	DAVIS OIL	48.20
0718060	GRAND RAPIDS NEWSPAPERS INC	43.60
1621125	PUBLIC UTILITIES COMMISSION	1,500.00
1915248	SOFTWARE HOUSE INTERNATIONAL	344.14
1920555	STOKES PRINTING COMPANY	14.42
TOTAL		1,950.36
LODGING TAX		
1920240	STERLE LAW OFFICE	260.00
TOTAL		260.00
TOTAL UN-PAID TO BE APPROVED		51,629.13
CHECKS ISSUED-PRIOR APPROVAL		
PRIOR APPROVAL		
0114210	D. ANDERSON - CHANGE FUND	1,320.00
0205640	LEAGUE OF MN CITIES INS TRUST	1,000.00
0209341	BIGFORK VALLEY HOSPITAL	38.08
0301400	CAKE KINGDOM	7.48
0301650	JEFF CARLSON	60.00
0315454	TRAVIS COLE	169.67
0315470	JAMES COLUMBUS	235.76
0418360	DRIVER & VEHICLE SERVICE DEPT	18.00
0421448	DULUTH CLINIC-DEER RIVER	59.61
0504610	RON EDMINSTER	121.89
0519700	ESSENTIA HEALTH	1,000.00
0605191	FIDELITY SECURITY LIFE INS CO	71.61

COUNCIL BILL LIST - APRIL 11, 2011

DATE: 04/06/11
 TIME: 15:45:15

CITY OF GRAND RAPIDS
 DEPARTMENT SUMMARY REPORT

PAGE: 6

INVOICES DUE ON/BEFORE 04/11/11

VENDOR #	NAME	AMOUNT DUE
CHECKS ISSUED-PRIOR APPROVAL		
PRIOR APPROVAL		
0609685	FIREMEN'S RELIEF ASSOCIATION	1,000.00
0612095	STEVEN FLAHERTY	38.00
0709225	WILBERT GIESE	16.00
0709456	SHAWN J GILLEN	950.00
0715561	MATTHEW GOOKINS	30.00
0717997	GRAND ITASCA HOSPITAL	1,000.00
0718015	GRAND RAPIDS CITY PAYROLL	178,080.10
0718070	GRAND RAPIDS STATE BANK	514.53
0815464	SARA HOLUM	30.00
0920055	ITASCA COUNTY RECORDER	46.00
0920060	ITASCA COUNTY TREASURER	2,606.09
1115643	ADAM KORTEKAAS	191.00
1201402	LAKE COUNTRY POWER	38.91
1205090	LEAGUE OF MINNESOTA CITIES	335.00
1209516	LINCOLN NATIONAL LIFE	768.96
1301642	MARAJ CONSTRUCTION INC	1,000.00
1305245	LOIS MEYER	8.93
1309079	S.MILLER - PETTY CASH FUND	4.34
1309150	MN CHIEFS OF POLICE ASSOC.	145.00
1309199	MINNESOTA ENERGY RESOURCES	2,492.23
1309338	MN STATE TREAS/BLDG INSPECTOR	2,025.83
1315295	CHAD MOEN	30.00
1315665	KELLY MORRIS	44.00
1401245	NATIONAL RIFLE ASSOCIATION	525.00
1405550	NEOPOST INC	1,000.00
1415035	NORTH COUNTRY BUSINESS PROD	2,510.34
1520720	KEVIN OTT	30.00
1609557	PIONEER MUTUAL LIFE INS CO	254.82
1621125	PUBLIC UTILITIES COMMISSION	800.00
1621130	P.U.C.	21,182.40
1723221	QWEST	275.33
1805295	REGENCE BLUE CROSS BLUE SHIELD	160.00
1809149	MICHAEL RICE	146.37
1901361	SMDC MEDICAL CENTER	65.56
1903321	STEVEN SCHAAR	139.36
1915734	SOUTH CENTRAL	180.00
2000100	TASC	29.70
2114360	UNITED PARCEL SERVICE	113.32
2205637	VERIZON WIRELESS	650.50
T000190	DETROIT LAKES FIRE CONFERENCE	900.00
	TOTAL PRIOR APPROVAL	224,459.72
	TOTAL ALL DEPARTMENTS	276,088.85