



CITY OF  
**GRAND RAPIDS**  
IT'S IN MINNESOTA'S NATURE

## ARTS & CULTURE COMMISSION MEETING AGENDA

NOTICE IS HEREBY GIVEN, that a regular meeting of the Arts & Culture Commission will be held in City Council Chambers at City Hall, 420 N Pokegama Avenue, Grand Rapids, Minnesota 55744 on Tuesday, March 2, 2021 at 3:45 PM.

### Agenda

1. Call to Order
2. Public Input
3. Setting the Agenda
4. Correspondence
5. Approve minutes: February 2, 2021 Regular meeting.
6. Financials: Current revenue/expenditure report
7. Artist in Residence
8. Old Business
  - Art Plan & Goal Setting
  - Goodwin Art Exhibit
  - Mayor's Art Award
  - Library Bike Rack Sculpture
9. New Business
  - Cultural Sensitivity with Art
  - Creative MN Economic Study
10. Announcements
11. Set Agenda For Next Meeting:
12. Adjourn

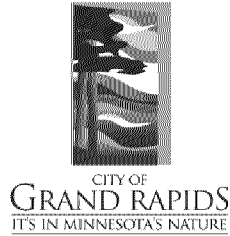

## ARTS AND CULTURE COMMISSION MINUTES

**CALL TO ORDER:** Pursuant to due notice and call thereof the regular meeting of the Grand Rapids Arts and Culture Commission was held in Council Chambers at 420 N. Pokegama Avenue, Grand Rapids, Minnesota on Tuesday, February 2, 2021 at 4:03 PM.

**Call of Roll:** On a call of roll, the following members were present: Ed Zabinski, Kayla Aubid, Kari Hedlund, Myrna Peterson, Jennifer Gorman, Gail Otteson, Tom Sippola, Sonja Merrild, Anne-Marie Erickson. Absent: None.

**Staff Present:** Tom Pagel, Will Richter, Kimberly Gibeau

**Public Input:** None.

### **Setting the Agenda:**

**Motion by Peterson, second by Erickson to approve the agenda as presented. Motion passed by unanimous vote.**

**Correspondence:** None.

### **Approval of Minutes:**

Noted correction: spelling of Commissioner Hedlund last name.

**Motion by Hedlund, second by Merrild to approve the minutes for November 10, 2020 with correction. Motion passed by unanimous vote.**

**Financials:** Fund consists of \$5,924 roll over from 2020 budget and current annual budget of \$7,500, providing a total balance of \$13,424 for 2021.

**Artist in Residence:** Katie Marshall provided update on current happenings at the artist loft. David Dobbs has agreed to assume management responsibilities for program.

### **Old Business:**

**Mapping Project:** Megan Christianson presented web application. Visit Grand Rapids will keep app updated.

Goodwin Art show: Commissioner Aubid is working with Mr. Pagel, Commissioner Hedlund and Will Richter. Discussed idea for developing panels to place in front of areas throughout the city, pictures of artists work with descriptions. Perhaps working with local writers and poets to reflect on sculpture being worked on at Riverside Park and have those on panels also. Will continue to develop ideas and return with more information at March meeting.

Library Public Art Project:

Mr. Richter states that he is currently waiting for a fresh site specific proposal from artist Greg Mueller for a sculpture to be placed near trail and fishing pier. Library board prefers a piece that is specific to the library, perhaps a functional piece. Updates on art project will be provided as they are received.

**New Business:**

Review of Art Plan: Members are encouraged to become familiar with plan for year two public art and plan to work on goal setting at March meeting, keeping in mind that the revenue coming into capital fund will be lower in 2021 due to less road construction projects.

City Email: All City Boards and Commissions are transitioning to official City emails. IT Department will be contacting members to set up and will continue through end of service.

**Announcements:**

- City creating “Rapids Riverfest”, to be held September 10 – 11, 2021. In planning process for entertainment and location. Would like to set up art village, a children’s area and include as many area businesses and restaurants as possible. We will continue to monitor the Covid impact and event would be cancelled if necessary.
- City is working with “May Mobility.” Limited art may be created for small areas near right-of-way.

**Items for next agenda:**

- Art Plan and Goal Setting
- Update on Goodwin Art Exhibit
- Mayor’s Art Award – Tom and Kim work on press release
- Cultural Sensitivity education

There being no further business, the meeting adjourned at 5:13 pm.

Respectfully submitted:

Kimberly Gibeau, City Clerk



## Creative Minnesota Economic Study

### Set a Solid Foundation for Arts and Cultural Recovery

Minnesota Citizens for the Arts (MCA) and its partners<sup>1</sup> are ready to enroll organizations, cities, counties, and regions for its next round of local economic studies. Let MCA provide you the tools you need to recover and grow your area's arts and cultural activity and economy.

MCA has conducted over 40 Creative Minnesota Economic Studies which have helped advocates achieve:

- New arts and cultural plans
- New or revived arts and cultural planning commissions
- Supportive resolutions with chambers of commerce, business organizations, and city councils
- Funding for new development and renovations
- Stronger partnerships with economic development agencies and business and workforce development groups
- New programming for events and education
- New public art works and memorials

Over the past year, arts and cultural venues shuttered and in-person activities ceased. The impact of the global health pandemic has been devastating to the creative sector. Nationally, over 94% of artists and creative workers reported lost income<sup>2</sup>. Arts and cultural nonprofits estimated financial losses at over \$10.2 billion. In Minnesota, 69% of arts and cultural nonprofits reported high levels of disruption due to the impacts of the pandemic and uprising<sup>3</sup>.

Amid the upset there are efforts to reassess and pivot to new practices, but we also know that this is an increasingly important sector, one that outperformed many other sectors in the recovery following the 2008 downturn.

Our economy relies more and more on creativity and innovation. Arts and culture are at the center of the growing knowledge economy where creative skills fuel the design and performance needs of the digital age in communications, marketing and promotions, and entertainment. A report by the Bureau of Economic Analysis (BEA) shows that in 2017, arts and cultural activity outperformed the transportation, construction, and agriculture industries<sup>4</sup>. Arts and culture contributed 4.5% of gross domestic product, or \$877.8 billion,

---

<sup>1</sup> McKnight Foundation, Minnesota State Arts Board, Forum of Regional Arts Councils of Minnesota, Target, Jerome Foundation, Mardag Foundation, Springboard for the Arts, Bush Foundation, and in-kind support from the Minnesota Historical Society, City of Minneapolis and others. For a list of committee members, go to <http://creativemn.org/study-partners/>.

<sup>2</sup> AftA. 2020. COVID-19's Impact on the Arts - Research & Tracking Update: August 3, 2020. Washington D. C.: American for the Arts.

<sup>3</sup> MCN. 2020. Minnesota Nonprofit Economy Report: COVID-19 Impact Update and Minnesota's Response to the Murder of George Floyd. St. Paul, MN: Minnesota Council of Nonprofits.

<sup>4</sup> BEA. 2020. Arts and Cultural Production Satellite Account, U.S. and States 2017. Washington D. C.: Bureau of Economic Analysis, Department of Commerce.





## Creative Minnesota Economic Study

representing an increase of 3.6% over 2016. Further, the sector generates a trade surplus and employs over 5.1 million people nationwide.

So, while we know arts and culture beautifies our landscapes, provides exciting experiences, and offers interesting learning opportunities it is also an important economic engine because while enlivening places, creativity improves property values and tax revenues and draws people to events, producing customers for nearby restaurants, bars, and shops. And, rich in for-profit businesses, entrepreneurship, and non-profit organizations that produce solid revenues, arts and culture fosters business and organization growth, leases and owns space, purchases supplies and services, and hires, develops and improves the skill sets of workers.

You recognize the value of the multifaceted arts and cultural sector. A Creative Minnesota Economic Study can set the foundation you need to help others understand and support this sector, ensuring a solid arts and cultural recovery and future. Let us quantify the state of your sector, based on 2018 data, giving you the foundational data and the economic language you need to plan for future growth in your creative sector.

The Creative Minnesota Economic Study quantifies and celebrates your important arts and cultural sector, empowering you to continue to celebrate the unique vibrancy and benefits artists and cultural bearers bring to your community.

Contact Brenda Kayzar at [Brenda@artsmn.org](mailto:Brenda@artsmn.org) or 612-730-7913 so we can share more details about the study.

Sincerely,  
Sheila Smith  
Executive Director





GRAND RAPIDS AREA LIBRARY:  
Grand Rapids, Minnesota

Preliminary Public Art Proposal  
*Revision: Bike Rack*

---

MUELLER STUDIO LLC





## CREATIVE INFLUENCE: Vessel Bike Rack Sculpture

---

- Historically the Birchbark canoe provided transport throughout Northern Minnesota's waterways, and its unique architecture, such as the hulls, have intriguing sculptural qualities.
- Indigenous translations of Pokegama Lake "...water which juts off from another water...the lake with bays branching out..."
- Vessels are a tool of exploration and discovery, much like the Grand Rapids Area Library
- Ann K Ryan, *Voices of Pokegama* ...go lightly over my waves and shores, you need me, I have brought you together and I will carry you forward, I am the rock I am the earth I am the water

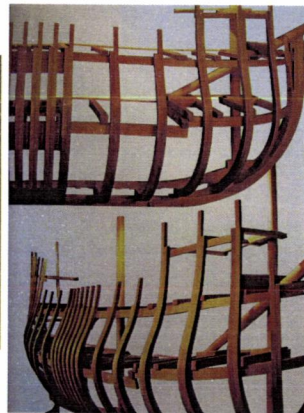
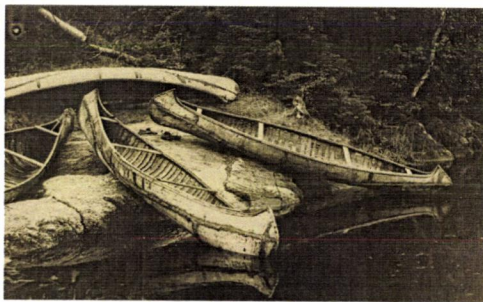

POKEGAMA TOWNSHIP derived this Ojibwe name from Pokegama Lake, translated by Gilfillan as "the water which juts off from another water," and "the lake with bays branching out." This large lake, having a very irregularly branched shape, nearly adjoins the Mississippi River.





# SITE and CONTEXT: BIKING RECREATION AND GRAND RAPIDS LIBRARY PUBLIC TRAIL





# DETAIL DRAWING 1: VESSEL FORM AS FUNCTIONAL PUBLIC ART

---

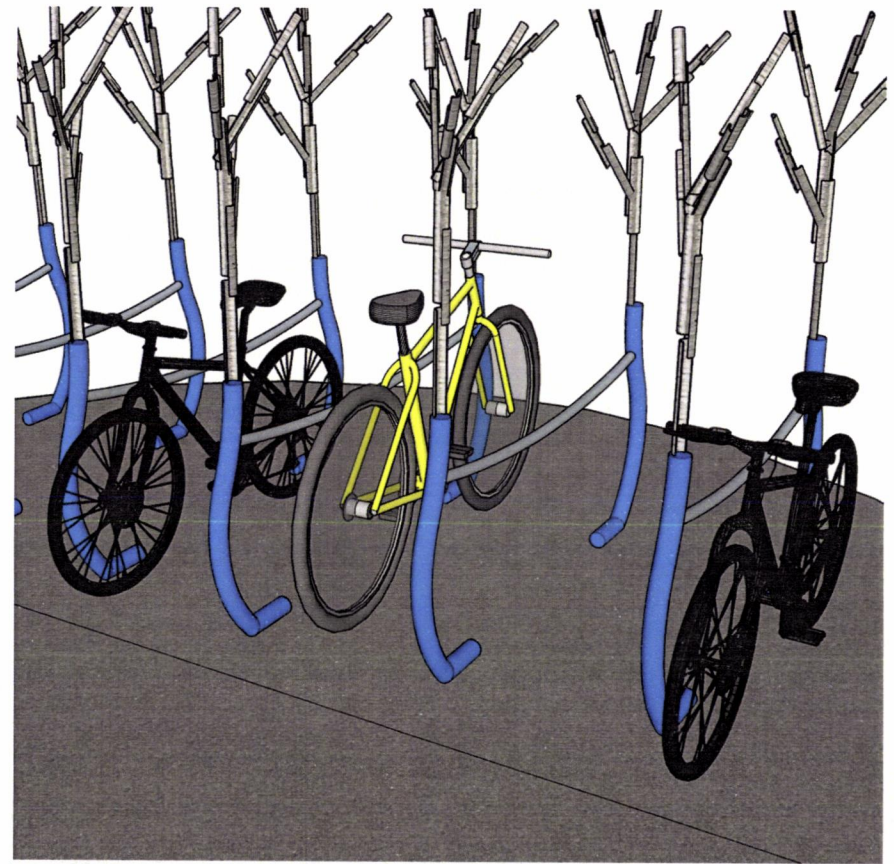
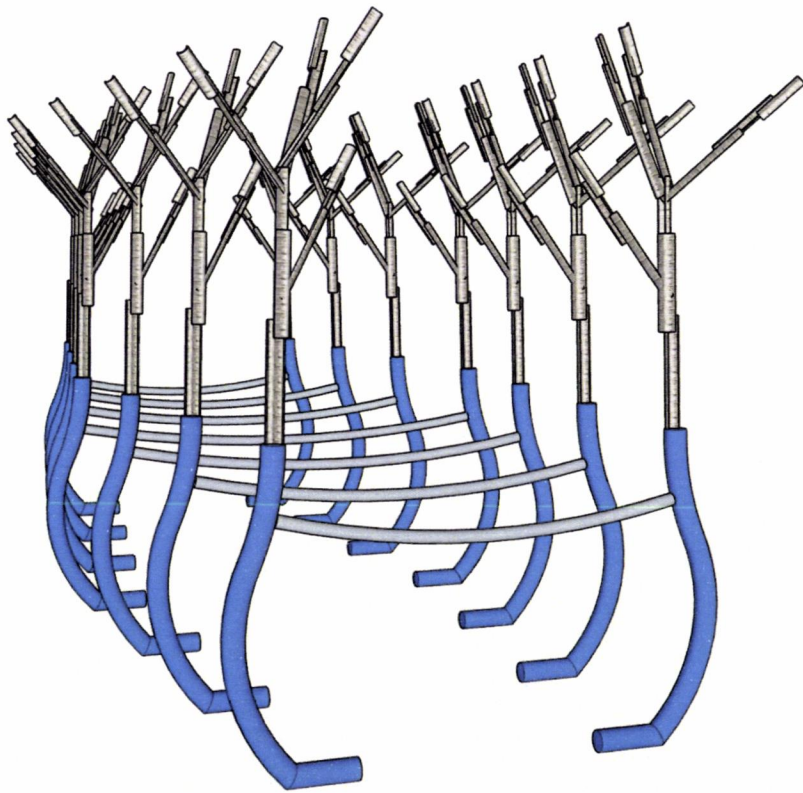



## DETAIL DRAWING 2: VESSEL BIKE RACK CONCEPT

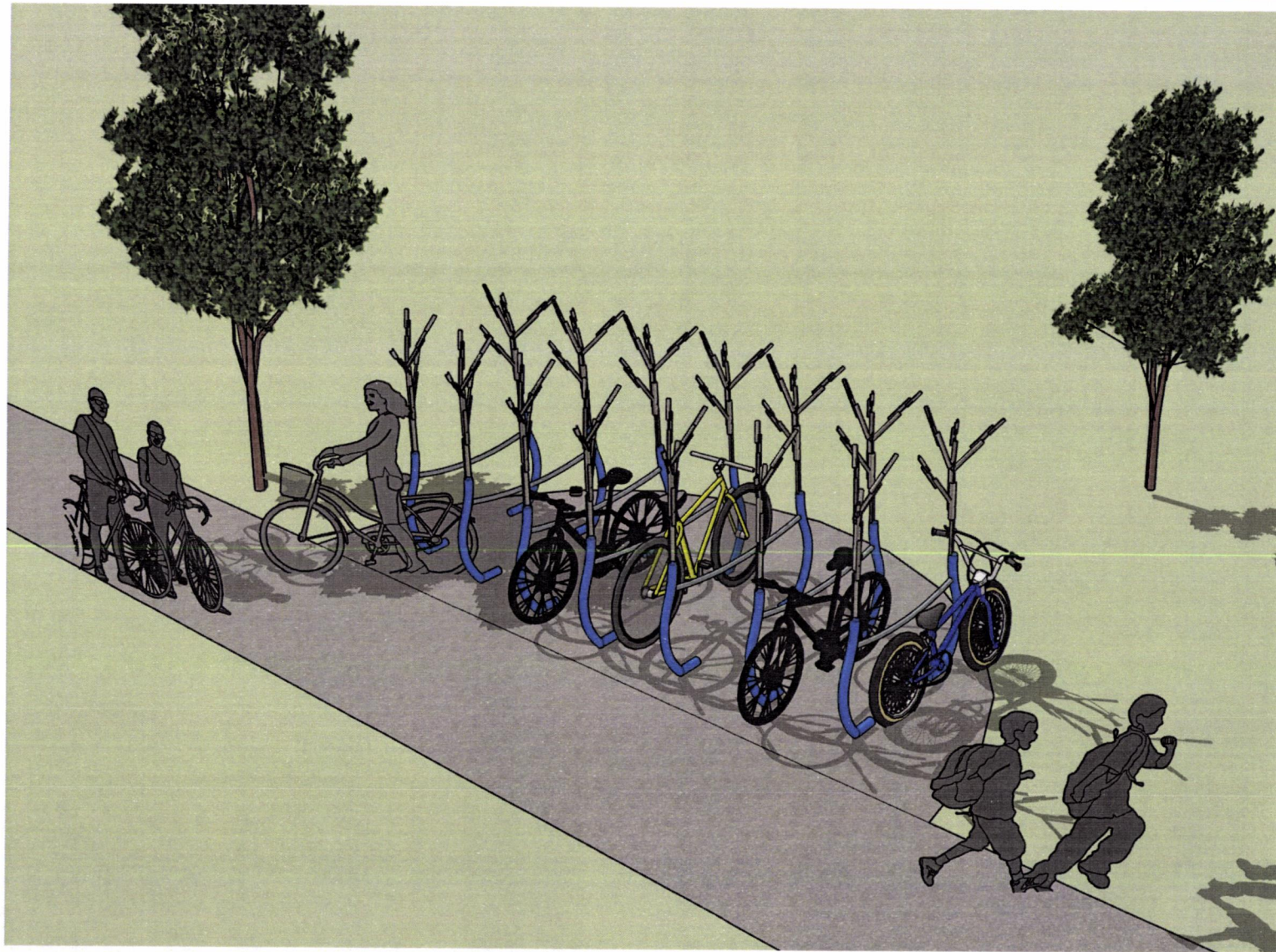



# DETAIL DRAWING 3: VESSEL BIKE RACK CONCEPT

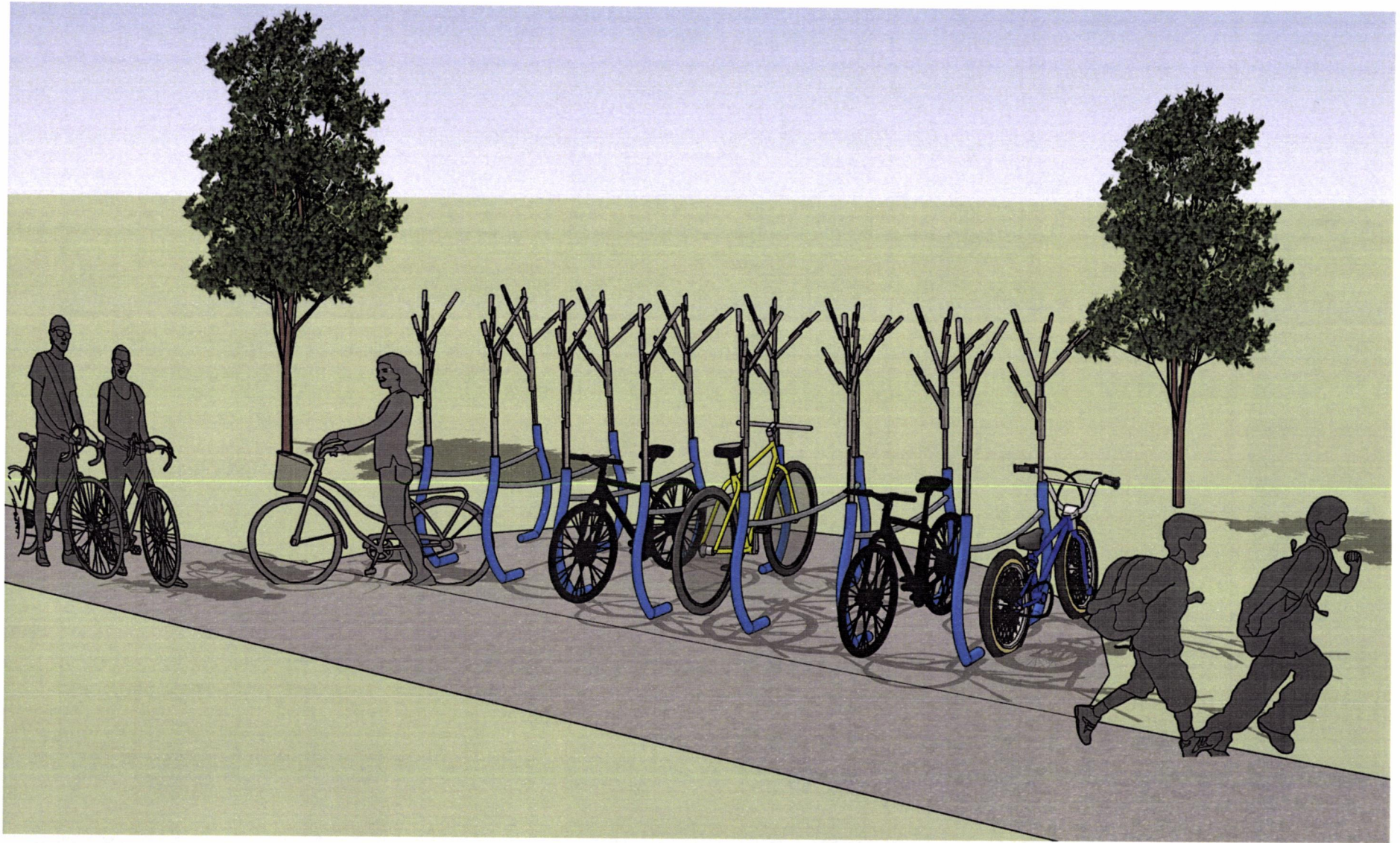



# DETAIL DRAWING 4: APPROXIMATE SCALE ( OPEN TO MODIFICATIONS)

3" diam hull / tree trunk: powder-coated steel tube

1" diam. - 2.5" diam. varied stainless tree branch forms

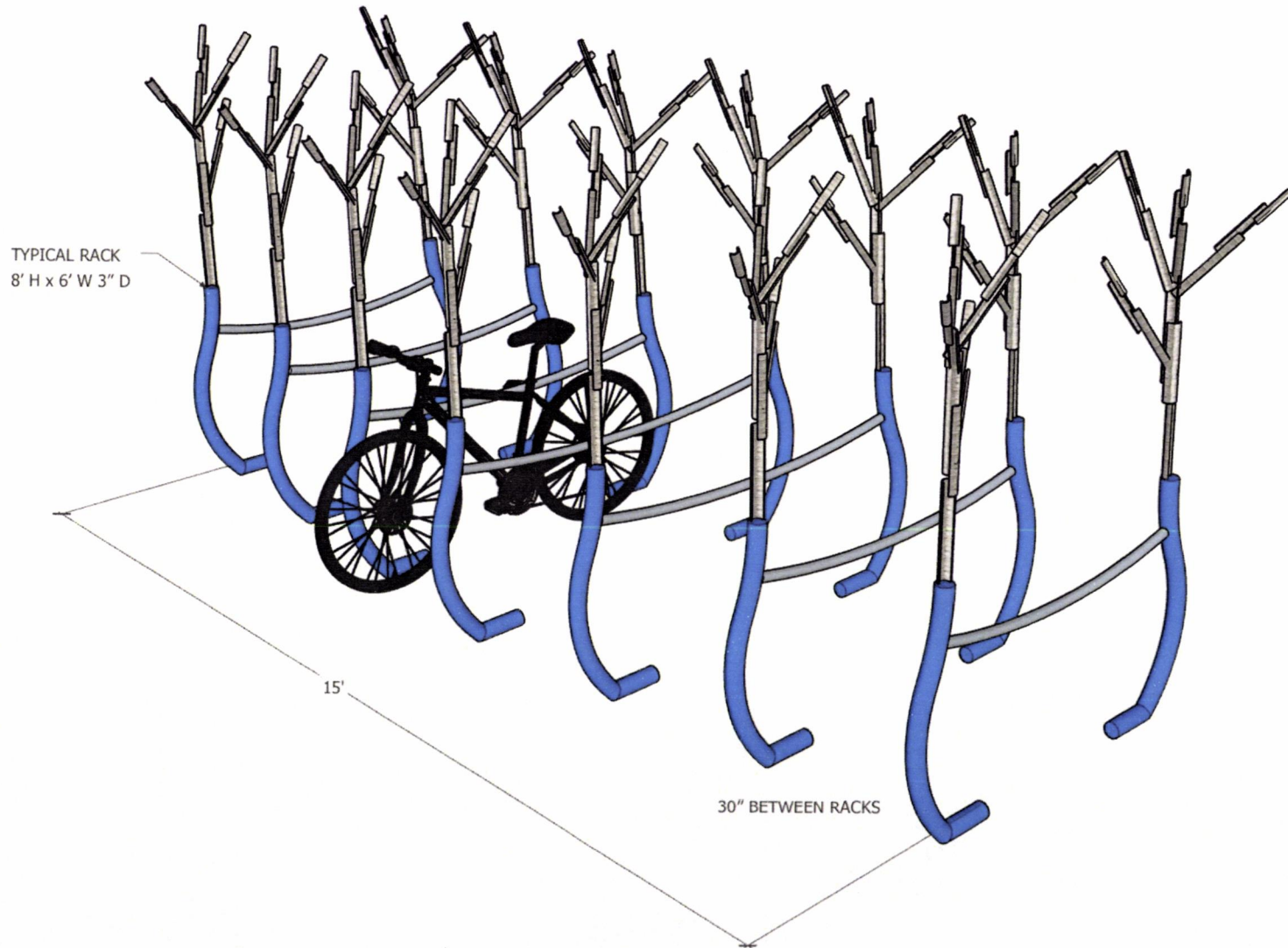

# DETAIL DRAWING 1: BIKE RACK SPACING

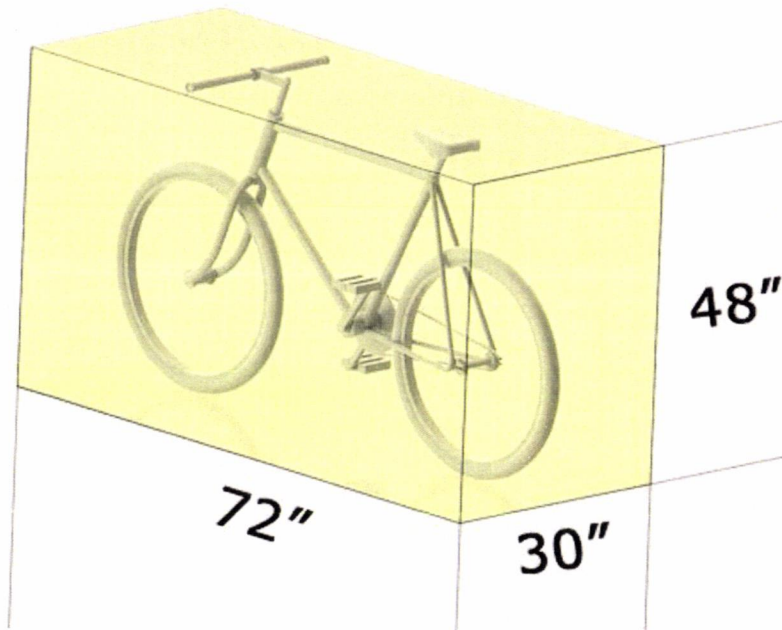

## Bike Rack Spacing

Spacing dimensions are only example suggestions and may not be suitable for specific locations. Dimensions do not account for walkways or other space considerations. Be sure to consult a design professional and any applicable municipal codes before installing.

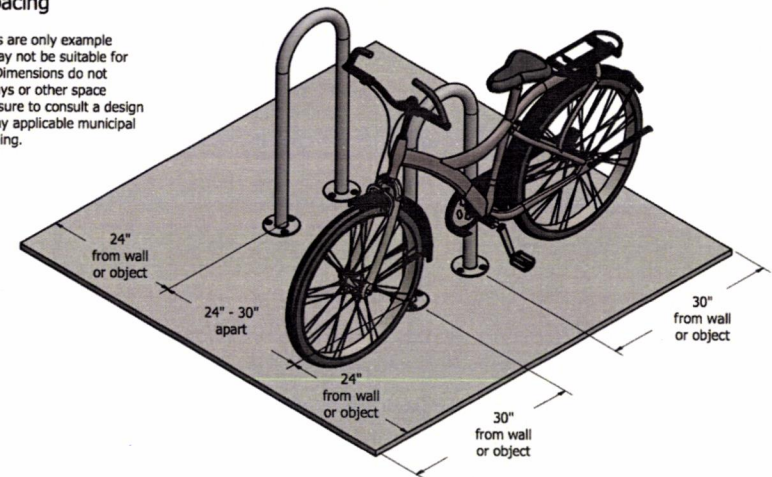

# CONSTRUCTION: DRAWING 1

---

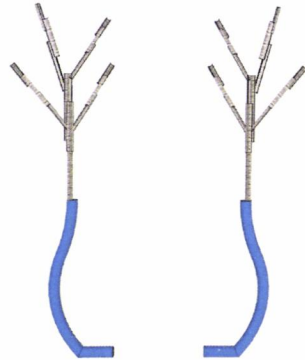
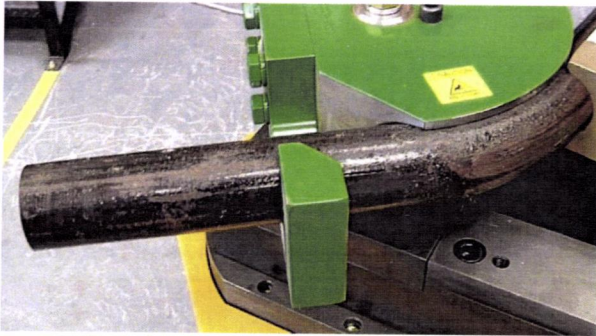

- MATERIALS:**
- “tree trunk/vessel hulls” pipe bending of ¼” thick pipe
  - birch branches composed of ¼” thick half pipe scroll forms
  - panels would include slit cuts - “lenticels”

**CONSTRUCTION NOTES:** each tree/vessel hull anchored into concrete pad





## POTENTIAL PARTNERS:

---



Linders Specialty Metal, St. Paul, Minnesota



Twin City Powder Coating, Lino Lakes, Minnesota

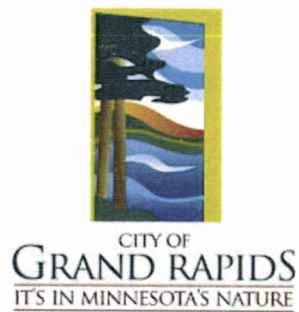

City of Grand Rapids

# DETAIL DRAWING 5: MAINTENANCE and CONSERVATION

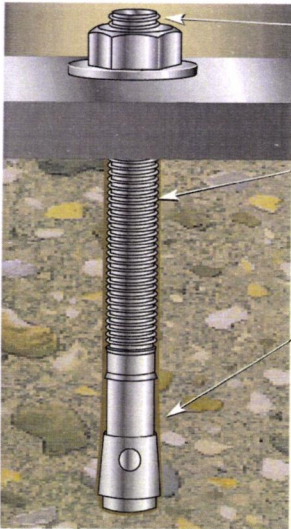

**Length ID Head Stamp**—provides for embedment inspection after installation

**Fully Threaded Design**

**Cold-Formed**—manufacturing process adds strength

**Stainless steel split expansion ring**

**Anchor Body**—available in zinc-plated steel, hot-dipped galvanized steel, 304 stainless steel and 316 stainless steel

**WEDGE ANCHOR**



3/4" STAINLESS THREAD ROD

# PROJECT FUNDING:

## PROJECT BUDGET: GRAND RAPIDS AREA LIBRARY

COMMISSION INCOME	
Project Budget	\$10,000
Additional income	
<b>Total income</b>	<b>\$10,000</b>

PRELIMINARY	

COMMISSION EXPENSES	
DESIGN FEE:	\$250
STUDIO LABOR:	\$6,500
STUDIO: CONSUMABLES	\$200
MATERIALS: steel, stainless,	\$500
POWDERCOATING EXT GRADE	\$800
LIABILITY INSURANCE	\$100
CONSULTANTS (Engineer / Architect)	\$0
TRAVEL MEETING PUBLIC WORKS	\$0
TRANSPORT TRUCKING	\$500
SITE PREP / FOOTINGS - OTHERS	\$0
INSTALLATION EQUIPMENT	\$0
INSTALLATION ASSIST / CONTRACTOR	\$0
LIGHTING	\$0
HIGH RES DOCUMENTATION	\$150
OFFICE / ADMINISTRATIVE	\$0
CONTINGENCIES 10%	\$1,000
<b>Total expenses</b>	<b>\$10,000</b>

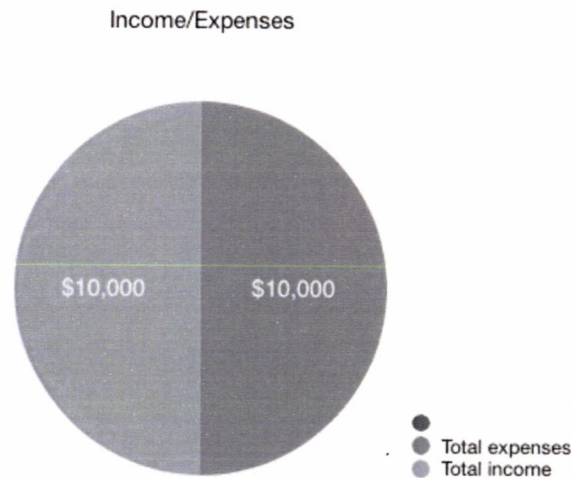



TIME LINE: (to be determined)

---



THANK YOU:

---

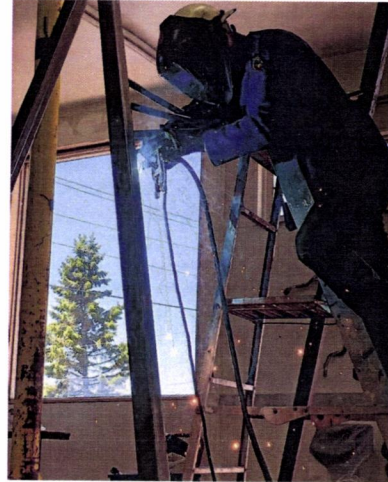

Mueller Studio LLC  
PO Box 196  
17 Railroad Drive  
Lutsen, MN 55612

[glmueLLerstudio@gmail.com](mailto:glmueLLerstudio@gmail.com)  
[www.greglmueLLer.com](http://www.greglmueLLer.com)